



Proven solutions for the toughest process measurements for over 40 years

HiQDTmA Loop Powered pH Sensors

These versatile plug-and-play 2-wire pH sensors easily retrofit into any existing PLC, DCS, or SCADA system.

They provide the ease and convenience of hot-swapping pre-calibrated sensors in the field, made possible with smart digital technology.

The scalable 4-20 output reflects the calibrated, temperature-compensated pH value, set to either inverted or non-inverted mode.



HiQDTmA loop powered pH sensors are paired with either an LED display (above) for safe areas or an LCD display (right) approved for use in hazardous areas.

All installation packages feature analog trim offset and span adjustment for the 4-20mA signal, ensuring precise readings with the connected control or data acquisition (DAQ) system.



Key Benefits

- ASTI's entire line of proven pH sensors is available in the HiQDTmA configuration, including inline, immersion, submersible, twist lock, sanitary, and HOT-TAP retractable.
- HiQDTmA smart digital sensors store calibration data, enabling quick plug-and-play hot swaps and reducing pH measurement downtime.
- Calibration and configuration can be performed with a cost-effective portable battery-powered Handheld Communicator (HHC), Windows software, or any compatible MODBUS RTU master device, including a touchscreen controller. A single HHC can be used for multiple installations.
- All features of the smart digital RS-485 HiQDT MODBUS RTU sensors are included in the HiQDTmA version. The ONLY difference is that the HiQDTmA version adds a simultaneous analog 2-wire 4-20mA current loop output.

Operational Advantages

- These sensors have 3 distinct operating modes for flexible field commissioning and use:
 - Sensor connected to HHC directly offline (digital only mode)
 - Sensor connected to loop powered display with no HHC connected (analog only mode)
 - HHC connected to loop powered display (dual analog and digital mode)
- Intelligent management of calibrations and service life-cycle provides efficient commissioning and maintenance. All aspects of an installation are easily portable from field to shop and back again.
- HiQDTmA sensors come standard terminated with a waterproof snap connector. They support bridging connections to easily modify installations without loss of signal quality up to 1,000 m (3,280 ft) with snap-to-snap waterproof extension cables. All connectors are NEMA 6P & IP67 rated quick disconnect, waterproof, and corrosion resistant.

Typical Workflow for Loop Powered Installations

1. These sensors come factory precalibrated with pH buffers and 4-20mA output default scaled to 0-14 pH. The sensor can be re-calibrated prior to installation and/or the scaling can be modified, if desired.
2. Install the sensor in the field and connect to the facility's PLC, DCS, or SCADA system. Connecting to the loop powered display completes the circuit and powers the sensor. If readings on connected PLC do not match expected values, perform analog trim adjustments on PLC using HHC to simulate 4mA and 20mA states. If analog input trim adjustments are not supported on the connected PLC, the analog trim adjustments can instead be performed on mA output signal from the sensor using the HHC.
3. If the reading on the loop powered display does not agree with values on PLC and HHC, the analog trim adjustment feature may be used to create agreement between all devices on current loop.
4. For offset adjustments, connect the HHC to adjust readings as needed based on grab sample analysis from the installation. The analog output hold feature does not need to be enabled for in-situ calibrations.
5. When performing pH buffer calibrations or cleaning with the sensor connected to the PLC, the analog output can be placed on hold prior to removing the sensor from the process.
6. Best workflow can be achieved with plug and play hot-swap of previously cleaned and calibrated HiQDTmA sensors, avoiding the need to clean and re-calibrate in the field.

Typical HiQDTmA Installation with LED Display for Non-Hazardous Areas



Complete field assembly is shown, including an HiQDTmA loop powered dual analog/digital mode sensor (on left) connected to an LED loop powered display with programmable relays (center) and Handheld Communicator (HHC, on right) to perform configuration and calibration.

The gray cable (not included) is the 24VDC power from the PLC that will energize both the loop powered LED display and the loop powered sensor. See wiring schematic (p. 5) for details.



Includes mounting hardware for wall, plate, or pipe installation (wall style shown above). There are 4 access points on the bottom of the unit:

Port on top row left accepts the loop powered sensor and port on top row right is used for the HHC.

Bottom row left cable gland is used for 24VDC loop power from the PLC.

Bottom row right cable gland is only used when the programmable dry contact relays are employed; otherwise, a sealing boot must be affixed.



The bridging adapter accessory for the HHC is shown connected to top right port. If either of the top ports is not in use, a sealing cap must be affixed. Assembly is NEMA 4X rated when fully installed. All connectors are NEMA 6P rated when interfaced.

Typical HiQDTmA Installation with LCD Display for Hazardous Areas

Complete field assembly is shown including an HiQDTmA loop powered dual analog/digital mode sensor (on left) connected to LCD loop powered display (center) and Handheld Communicator (HHC, on right) to perform configuration and calibration functions. The bridging adapter accessory for HHC is shown connected to the right port.

The gray cable shown to center is the 24VDC power from PLC that energizes both the loop powered LCD display and sensor. The green 35mm DIN-RAIL module shown to right bottom provides passive current loop isolation. See wiring schematic on (p. 5) for further details.



The LCD loop powered display assembly has the left port to interface with the HiQDTmA sensor. When connected the sensor completes the circuit and allows for all devices on the current loop to be energized.

The right port is used with HHC to perform functions discussed on page 2 in “Typical Workflow for Loop Powered Installations” section like calibration and trim.

Configuration and trim adjustments on LCD loop powered display itself can be achieved from the field with push button controls or via USB from a Windows PC.

- If a **non-isolated** type HiQDTmA sensor is employed, a current loop isolator is required to be installed before interfacing with PLC. That passive current loop isolator device is shown to the far right as the green 35mm DIN-RAIL mountable device.
- If an **isolated** type HiQDTmA sensor is employed, a separate external isolator is not required.
- The LCD installation assembly can be installed in either a plate mount or pipe mount configuration.
- All port connections are waterproof NEMA 6P rated when interfaced to ensure integrity of electronics.
- Consult PD6066 manual for details on hazardous area certifications of LCD loop powered display.

Wiring for LED Display- Safe Areas

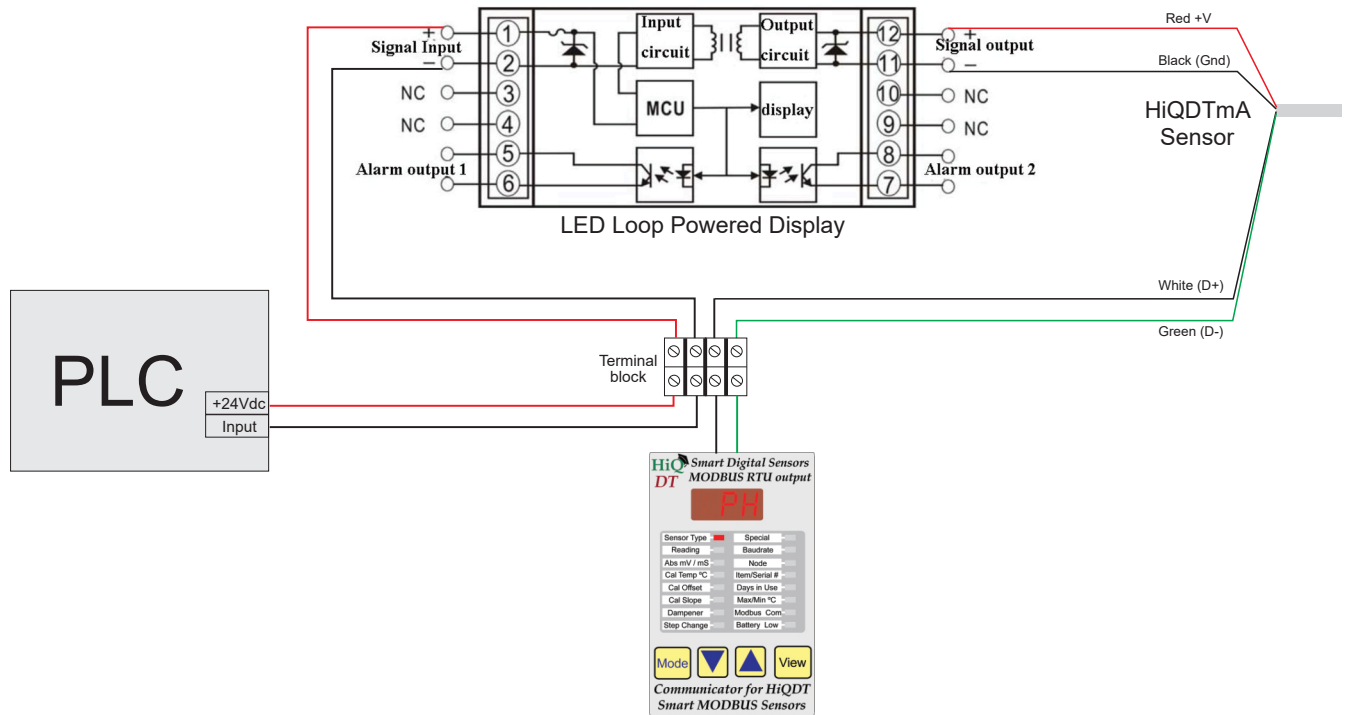

Wiring for LCD Display- Hazardous Use

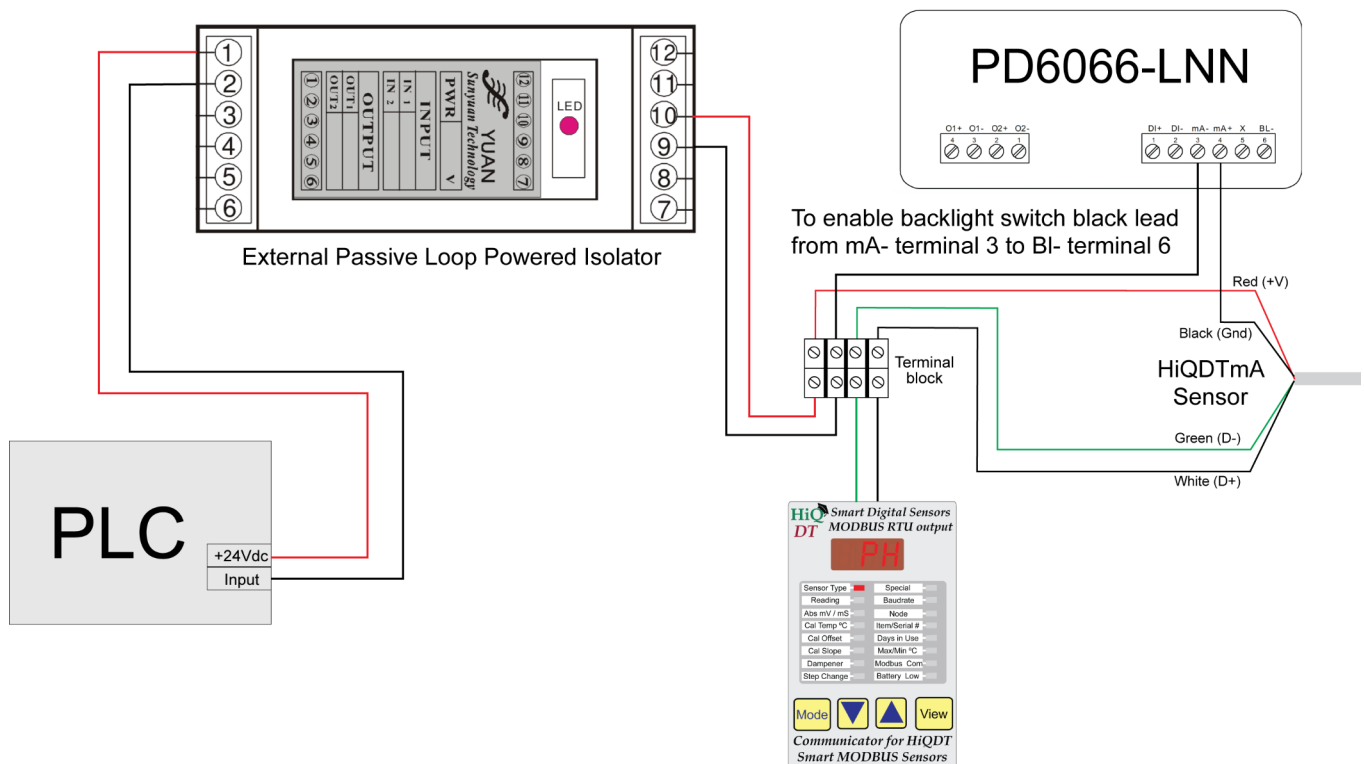

Industrial Internet of Things Features

- Tracks temperature, offset, acid, and base slope calibrations.
- Monitors time since last calibration for maintenance planning.
- Logs sensor manufacture date, item number, and serial number.
- Tracks total usage time for reordering and inventory control.
- Enables remote access to all smart sensor features via MODBUS RTU master.

Wiring, Use, and Installation Notes

- All connections are prewired at the factory and internal to the loop powered display assembly. The wiring schematics on page 5 are for reference only in case of accidental disconnection of leads. The power cable from the PLC is not included.
- When the dual analog/ digital mode HiQDTmA sensor is connected, it completes the current loop and the LED or LCD loop powered display is energized, showing the current process value based upon scaling set and present sensor reading.
- The HHC can perform changes such as scaling the current loop or performing an in-situ offset calibration. If the sensor is removed from process for calibrations with pH buffers, the analog output may be placed on hold with the HHC to avoid disruptions to any connected closed loop control systems.
- Isolation options:
 - **The LED display has integral passive galvanic isolation**, so non-isolated HiQDTmA sensors can be used without any external isolation being employed. It is possible to use an isolated HiQDTmA sensor, though that is not typically necessary for LED installations.
 - **The LCD display DOES NOT have integral passive galvanic isolation.** If a non-isolated HiQDTmA sensor is used, an external isolator is required. Such an external isolator is shown to the top left in the LCD wiring schematic. If an isolated style HiQDTmA sensor is employed, the external isolation device is not necessary.
- Scaling of analog output can be as little as 1pH unit between 4mA & 20mA set-points. Output is reversible, so it can be non-inverted (standard) or inverted (optional).
- For best agreement on the data acquisition device, reduce scaling to the narrowest possible range and perform an in-situ 4mA trim offset and 20mA trim span calibration at the process temp.
- The HiQDTmA sensor will operate in 1 of 3 modes, determined by operating voltage at startup:
 - Loop powered pH sensor with no digital communications (analog only mode)
 - Both a loop powered pH sensor and smart digital sensor (dual analog and digital mode)
 - A smart digital sensor only (digital only mode).

Smart Digital Only Sensor Mode Specs

Power Supply:	7 to 13 VDC – Non-Isolated 9 to 14 VDC – Isolated
Consumption:	4.0 mA max
Output:	HiQDT MODBUS RTU pH sensor (see programming guide for details)
Max Cable:	Up to 1,000 meters with 12VDC supply.

Analog & Smart Digital Dual Sensor Mode Specs

Power Supply:	24 to 30 VDC – Non-Isolated 24 to 32 VDC – Isolated
Consumption:	2-wire loop powered device
Output:	4-20mA ± 0.02 mA 500 Ω Max Load and HiQDT MODBUS RTU communications
Max Cable:	As allowed by 500 Ω Max Load Rating
pH Input Range:	-2.000 to +16.000 *
Temp Input Range:	-40 to +210 $^{\circ}$ C * $\pm 0.3^{\circ}$ C - used for Automatic Temperature Compensation (ATC)
Min Scaling:	Min 1pH unit between 4-20mA
Max Scaling:	-2 to +16 pH
Polarity:	Non-Inverted or Inverted
Trim:	$\pm 9.99\%$ for both trim offset & span
Sensor Board Temp Limits:	-40 to +125 $^{\circ}$ C – Non-Isolated ** -40 to +85 $^{\circ}$ C – Isolated **
Approvals:	CE EN61326A and RoHS 

For details about smart digital only HiQDT MODBUS RTU operation mode, please refer to separate documentation.

* The actual pH range and temperature input range will be limited by the model of pH sensor selected.

** Temperature limits indicated are at the sensor board itself, which typically means this is the limit for fully submersible use.

Loop Powered Display Configuration Specs

Feature or Functionality	LED Loop Powered Display for SAFE AREAS	LCD Loop Powered Display for HAZARDOUS AREAS
Display Type	3½ digit LED display	Dual line 5 digit top & 8 digit bottom alphanumeric display with back light
Display Range	-2.00 to +16.00 for pH; decimal position is adjustable to X.XXX or XX.XX or XXX.X or XXXX. Default is 0.00 to 14.00 pH scaling, which is also the default for all mating HiQDTmA pH sensors.	
Power & Load	24 to 30 VDC 2-wire operation; 500Ω max external load (<i>excluding any load from loop powered display or sensor itself</i>).	
Scaling Limit	Minimum 1.00 pH unit between 4mA & 20mA; scaling of display and HiQDTmA sensor must be matched.	
Output Hold	Yes; standard feature for HiQDTmA sensors. Can be enabled with Handheld Communicator or Windows software.	
Analog Trim	Yes; push button controlled.	Yes; push button controlled or via USB with Windows PC
Passive Isolation	Yes, with 3KV rating. Can be used with non-isolated HiQDTmA sensor without external isolation required.	No. Must use ISOLATED HiQDTmA sensor or external isolation device with non-isolated HiQDTmA sensor.
Relays	Yes; 2 each independent dry contact alarms included standard	Optional; Inquire to factory if required.
Installation Styles	CSA & UL NEMA 4X rated enclosure assemblies; standard with wall, plate and pipe mounting kits.	CSA & UL NEMA 4X rated enclosure assemblies; standard plate style mount; pipe mounting kit optional
Interface	All configuration details are achieved with digital microprocessor push button controls.	All configuration tasks achieved with digital microprocessor push button controls or USB with Windows PC
Input Ports	<ul style="list-style-type: none"> • 1 each HiQ4FP connector for HiQDTmA Sensor. • 1 each HiQ4FP connector for HHC. • 2 each ¼" NPT glands for loop power and relay wiring. 	<ul style="list-style-type: none"> • 1 each HiQ4FP connector for HiQDTmA Sensor. • 1 each HiQ4FP connector for HHC. • 1 each ½" NPT gland for loop power.
Calibration Methods	<ul style="list-style-type: none"> • Windows software OR Handheld Communicator OR touchscreen interface. • Auto-buffer calibration on Windows and touchscreen for 1.68, 4.00, 6.86, 7.00, 9.18, 10.00, and 12.45 pH buffers. • Separate slope for acid conditions (pH <7) and alkaline conditions (pH >7) supported for ALL calibration methods. 	
Approvals	Suitable for safe non-hazardous locations.	C-UL Intrinsically Safe and Nonincendive ATEX & IECEx Certified as Intrinsically Safe
Temperatures	-40 to 75°C operating; -40 to 85°C in storage.	-40 to 70°C both for operation and storage.
Accessories (Sold Separately)	<ul style="list-style-type: none"> • Handheld Communicator (HHC) if in-situ offset calibration or pH buffer calibration in the field is desired. At least one HHC is recommended for each facility. • Bridging adapter cable for HHC to connect with loop powered displays for HiQDTmA sensors. Only required if the sensor is to be interfaced while loop powered. 	



Proven solutions for the toughest process measurements for over 40 years

Contact Information

ETA Process Instrumentation

etapii.com

sales@etapii.com

tel: 978.532.1330

New England

Martech Controls

etapii.com

sales@martechcontrols.com

tel: 315.876.9120

Upstate New York

Manufacturing Custom Built to Order Measurement Solutions

Analog sensors and Smart Digital pH, ORP, Dissolved Oxygen (DO), Ion Selective (ISE) and Conductivity (EC) sensors for the Industrial Internet of Things (IIoT). Our smart digital sensors support direct integration with customer PLC, DCS, and SCADA for inline, immersion, submersible, sanitary, & HOT-TAP valve retractable installations.

Interface sensors directly via RS-485 MODBUS RTU or MODBUS TCP (Modbus over ethernet) with advanced menu-driven multi-channel touchscreen controllers with full remote access capabilities for HMI and remote download of logged data over FTP.

Ready To Inquire About Your Application?

To help us determine the best ASTI solutions to meet your measurement and control needs, please visit the link at the bottom of the page and fill out the form as completely as possible. We look forward to the opportunity to assist you.