

ML15F PA Horn Loudspeaker

The ML15F 15W PA loudspeaker is suitable for harsh environments with high ambient noise levels.

The ML15F features IP66 & IP67 (Type 4/4X/13) enclosures and re-entrant flare horns manufactured from high impact, fire retardant ABS. All models have dual cable entries and large termination areas containing in & out terminals. Available with 70 and 100V line transformers or in 8 or 16 Ohm low impedance versions.

The 70V line model is UL & cUL approved for Fire Alarm & Emergency and Professional & Commercial use for the US and Canada.

Features

- Ingress protection IP66/67 Type 4/4X/13
- Large termination area
- Dual M20 or 1/2"NPT cable entries – adaptors available
- Stopping plug included
- 316 (A4) Stainless steel mounting bracket
- Ratchet adjustable 'U' bracket for 360° positioning
- Duplicate cable terminations
- Fire Alarm & Emergency and Professional & Commercial use

Approvals

- UL 1480, Fifth Edition
CAN/ULC-S541-07
CSA C22.2 No. 205-12
UL category codes:
UUMW / UUMW7
UEAY / UEAY7
- EAC compliant: RU D-GB.GA05.B.12595-20
- Russian Maritime Register of Shipping
Cert: No. 19.00193.278
- CSFM listing: 7320-2279:0502



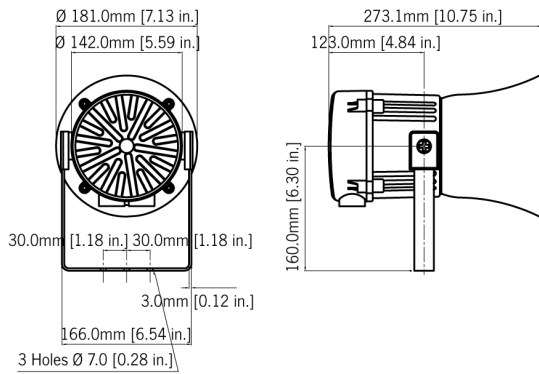

Specification

SPL:	108dB +/-3dB @ 1w @ 1m – Pink noise 118dB +/-3dB @ 15w @ 1m
Rated power:	15 Watts RMS
70v line tappings:	15w / 7.5w / 3w / 1w (z=336.67 Ohms / 653.33 Ohms / 1.6kOhms / 4.9kOhms)
100v line tappings:	15w / 7.5w / 3w / 1w (z=666.87 Ohms / 1.34kOhms / 3.34kOhms / 10kOhms)
Low impedance:	8 Ohm or 16 Ohm
Dispersion:	120° @ 1kHz & 32° @ 4kHz
Frequency range:	400Hz to 8000 Hz
DC Line monitoring:	2.2uF Capacitor (Transformer version) 470uF Capacitor (Low impedance version)
Ingress protection:	IP66 & IP67 (Third party tested) UL50E / NEMA250: 4/4X/3R/13
Enclosure material:	High impact UL94 V0 & 5VA FR ABS
Enclosure colour:	Grey (RAL7038) or Red (RAL3000)
Cable entries:	2 x M20; 1 x M20 & 1 x 1/2" NPT; 2 x 1/2" NPT supplied with blanking plug
Terminals:	0.5 – 2.5mm ² (20-14 AWG)
Operating temp:	-40 to +66° C [-40° to +151° F]
Storage temp:	-40 to +70° C [-40° to +158° F]
Relative humidity:	95% at 20° C [68° F]
Weight:	70/100v line: 2.60kg/5.72lbs Low impedance: 2.20kg/4.84lbs

*SPL data +/-3dB(A). Measured at optimum voltage.

Part Codes

Variable:	Identifier:	Description:
Product type:	ML15	15WPA Loudspeaker
Horn type:	F	Flare reentrant horn
Type:	V100 V070 R008 R016	100V Line 70V Line 8 Ohm Low impedance 16 Ohm Low impedance
Cable entries: [e]	A B C	M20x1.5 & 1/2" NPT M20x1.5 & M20x1.5 (Default) 1/2" NPT & 1/2" NPT
Stopping plug material: [m]	N	Nylon
Bracket: [s]	1 3	316 (A4) Stainless Steel 316 (A4) Stainless Steel with Equipment tag
Approvals:	A1 B1	CE, EAC, RMRS UL, cUL
Enclosure: [x]	G R	Grey (RAL7038) Red (RAL3000)
*NOTE:		UL & cUL approval only available on 70V line version
Accessories:	SP65-0001-A4 SP65-0003-A4	Pole Mount Bracket Kit 2" St/St 316 (A4) Sunshade – St/St 316 (A4)

ETA Process Instrumentation

www.etapii.com

sales@etapii.com

tel 978.532.1330

Martech Controls

www.martechcontrols.com

sales@martechcontrols.com

tel: 315.876.9120