



APPLICATIONS COMPENDIUM

Energy Efficiency, Monitoring and Sustainability

- Sustainable power and heat generation
- Efficient use of energy sources
- Monitoring of energy and greenhouse gas equivalents

ETA Process Instrumentation

www.etapii.com
sales@etapii.com
 tel 978.532.1330

New England

Martech Controls

www.martechcontrols.com
sales@martechcontrols.com
 tel: 315.876.9120

Upstate New York

KROHNE

■ PREFACE

Dear reader,

The energy transition is forcing companies to act.

Energy utilities are faced with the challenge of ensuring a supply of electricity, heat, gas and other forms of energy that is as CO₂-neutral as possible. The path to decarbonisation is being taken through a growing contribution of renewable energies, more efficient use of fossil fuels and the intermediate storage of excess energy. New technologies such as load-flexible high-efficiency power plants, green hydrogen and high-temperature heat storage must be developed and further expanded on a large scale for this purpose.

On the consumer side, too, the energy transition requires increased efforts on the part of industry and end consumers. Industrial companies are confronted with rising energy costs and are challenged by legal obligations to make their industrial processes more efficient and sustainable. Unavoidable process waste heat must be reused elsewhere or recuperated.

As a full-scope supplier of process instrumentation, KROHNE helps its customers meet the challenges of the energy transition. KROHNE instruments and measuring solutions can be found in almost all industrial sectors. This includes the measurement of thermal energy sources such as hot water, cold, steam or even liquid salt as well as the billing measurement of green hydrogen or the monitoring of other gases and liquids to optimise the efficiency of industrial processes.

This compendium comprises a selection of sample applications that demonstrate the added value of cutting-edge measurement technology to increase efficiency and monitor energy flows or greenhouse gas equivalents. We hope you will enjoy browsing through our applications compendium.

If you need more information on any of these applications, or if you have a challenge we can solve for you, please do not hesitate to contact us at application@krohne.com

Your KROHNE Applications Team

Power Generation	6
Oil & Gas	26
Chemical	36
Steel & Metal	50
Food & Beverage	58
Water & Wastewater	68
Marine	78

CONTENTS

Industry	Application	Medium
Power Generation	Enhanced energy measurement for a facility heating and cooling system	Heat (hot water)
	Flow measurement of superheated steam for an absorption chiller	Steam
	Heat metering at a transfer station of a district heating pipeline	Heat (hot water)
	Custody transfer (CT) flow measurement for a natural gas fuel system	Natural gas
	Flow measurement of green hydrogen at a power-2-gas plant (P2G)	Hydrogen
	Equipping a biomass plant with process instrumentation for billing steam quantities	Steam
Oil & Gas	Flow measurement for billing of a hydrogen/natural gas mixture	Hydrogen
	Upgrading gas receival stations with standardized electrical cabinets	Natural gas, Hydrogen
	Leak detection on a CO ₂ pipeline	CO ₂
	Monitoring energy consumption at an oil and gas field	Fuels
Chemical	Determination of steam quantities from a gas-fired boiler plant	Steam
	Establishing energy efficiency	Steam
	Custody transfer flow measurement of hydrogen	Hydrogen
	Differential pressure measurement for an ultra-high-pressure application in an oxo plant	Hydrogen
	On-site verification of process flows at catalyst plants	Different liquids
Steel & Metal	High temperature flow measurement of CO ₂ and H ₂ from a reactor column	Hydrogen, CO ₂
	Hydrogen flow measurement in tungsten production	Hydrogen
Food & Beverage	Multiparameter biogas measurement	Biogas
	Monitoring and control of CIP return lines in a dairy	CIP fluids
	Flow measurement of liquid nitrogen for tunnel freezers	Nitrogen
	Energy management for a sustainable beer production	Different media
Water & Wastewater	Flow measurement of wet biogas	Biogas
	Gauge pressure measurement in the aerator line of an aeration basin	Air
	Leak management system with GPRS remote monitoring in the Rio de Janeiro drinking water network	Water
Marine	Ultrasonic flow measurement of hydrocarbon vapors	Hydrocarbon vapors
	Fuel consumption monitoring and reporting on LPG tankers	LNG
	Fuel consumption and emission monitoring on a hospital ship	Bunker fuels

Power, Heat, Utilities	New energies	Monitoring (GHG / Energy / CT)	Efficiency improvement
x	x	x	x
x			x
x	x	x	
x		x	
x	x	x	
x	x	x	x
x	x	x	
x	x	x	
	x	x	
		x	x
x		x	
x		x	
	x	x	
			x
			x
	x		x
			x
	x	x	
			x
			x
x			x
	x		
			x
			x
		x	x
		x	x



Power Generation

- Enhanced energy measurement for a facility heating and cooling system..... 8
- Flow measurement of superheated steam for an absorption chiller..... 12
- Heat metering at a transfer station of a district heating pipeline..... 14
- Custody transfer (CT) flow measurement for a natural gas fuel system..... 16
- Flow measurement of green hydrogen at a power-2-gas plant (P2G)..... 18
- Equipping a biomass plant with process instrumentation
for billing steam quantities..... 22



APPLICATION REPORT

Enhanced energy measurement for a facility heating and cooling system

- Carbon-friendly air conditioning concept for office and manufacturing buildings
- Energy savings through continuous monitoring and optimisation of energy and heat flows
- Dedicated energy measurement setup consisting of flowmeters with paired temperature sensors and energy calculators

1. Background

Rising energy costs and growing regulatory requirements are encouraging many building owners and management companies to optimise their energy consumption. A major cost driver is the production and use of thermal energy for heating or cooling of manufacturing, commercial or industrial buildings.

When the KROHNE Group, one of the world's leading suppliers of process instrumentation, had a new multi-story office building built at its headquarters in Duisburg, Germany, a few years ago, the company made the deliberate decision to use sustainable geothermal heating and air conditioning technology to meet or exceed the latest government specifications (Energy Saving Ordinance or EnEV). Like most facilities in northern climates, the heating and cooling air conditioning system operates in different modes in winter and summer. The main energy sources for this system are:

- Wells that store or extract geothermal heat energy from a depth of 155 m / 508.5 ft
- A hybrid recooling plant
- A network connection to the municipal district heating system and
- A gas-powered humidifier.

A heat pump is used in the central air-conditioning system. The building features radiant ceiling cooling with concrete core activation and water-air heat exchangers for air heating.

2. Measurement requirements

In the summer months, the cooling carrier medium passes through a hybrid cooler, which dissipates the heat and thus cools it down. The cooling medium then passes through piping that is installed within the concrete elements and corridor floors of the seven-story building. The concrete core and underfloor cooling is

extremely effective and energy efficient. It reliably cools the offices to a comfortable working environment even at very high outdoor temperatures. If required, adiabatic, or evaporative, cooling can be activated in addition to dry cooling. In the winter months, the system uses geothermal heat or heat recovery to heat the concrete core, as well as supplying underfloor heating. Additional municipal district heating energy is only occasionally fed into the system when and if required.

Operating the system in the most cost-saving and sustainable way made it necessary to introduce comprehensive energy management. Clearly understanding the actual and long-term energy consumption, spontaneously occurring load peaks and average energy losses through better measurements helped to determine the system's optimal characteristics so that steps could be taken to gradually bring the system performance closer to the ideal.

Measurement and control technology had a crucial role in this. Therefore, KROHNE identified measuring points within the internal heating and cooling system to determine the current as well as the total consumption of thermal energy. The focus was particularly on the energy measurements in the cold and hot water circuits between the geothermal probes, the heat pumps and the heating systems, as well as between the heat exchangers and the concrete core piping in the building as shown in the process diagram below.

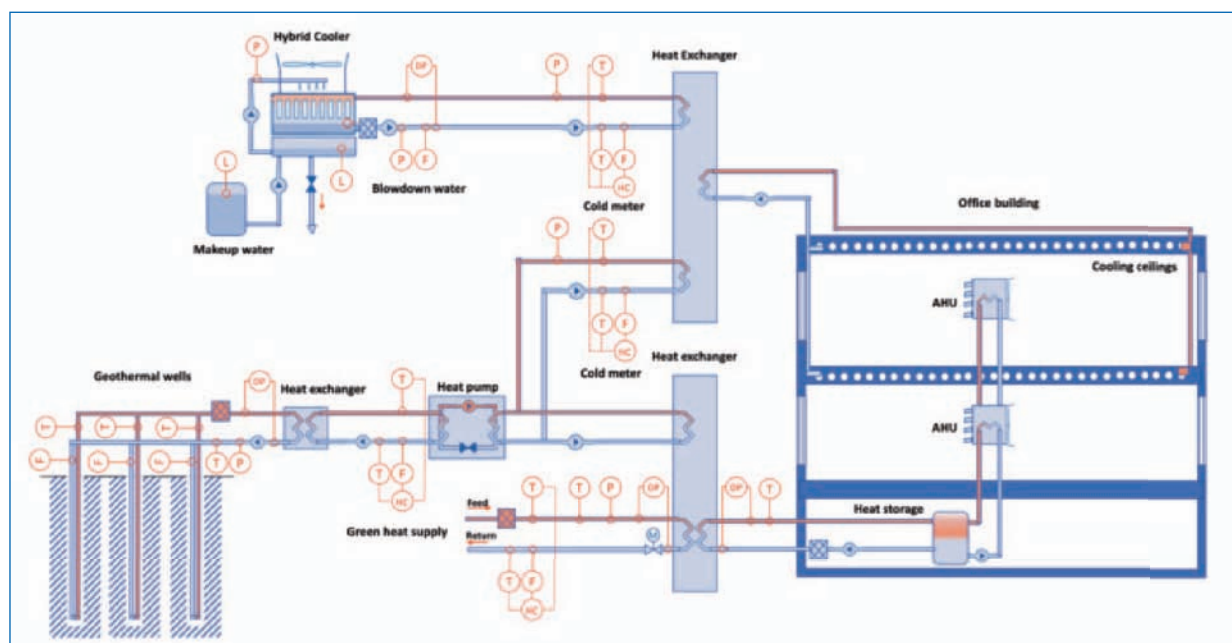

Process flow chart of the cooling and heating system

3. KROHNE solution

Due to the existing conditions, including many measuring points with limited installation space and only short straight inlet/outlet runs, KROHNE predominantly used WATERFLUX 3300 electromagnetic flowmeters (EMF). These meters monitor the heating and cooling water circuits and determine the transferred thermal energy. A range of DN50...125 flowmeters measure hot and cold-water flow rates for concrete core heating or cooling as well as the water quantities returned to the geothermal probes. These EMFs are designed for flow measurement of the conditioned, but still sufficiently conductive heat transfer medium. Due to their high accuracy and long-term stability, they are also certified as cold and heat meters in DIN EN 1434 / MI-004 applications. The measuring devices are used as compact version (C) or, depending on the installation, with remote transmitter as field version (F). The sensors are mainly insulated in the pipes to avoid medium heat loss.



WATERFLUX 3300 measures the return flow to the geothermal probes

To record the thermal energy consumed in the heating system, the heating system is additionally equipped with paired OPTITEMP TRA-12 temperature sensors. Based on the flow rates and temperatures, a heat calculator determines the incoming thermal energy and what is consumed and transfers that information to an energy data monitoring system that graphically displays the measured data for visualisation.

Since this innovative office building heating of the was installed, natural gas consumption at the site has already been significantly reduced. The volume of natural gas consumed by KROHNE's nearby production facility is monitored by an OPTISONIC 7300 ultrasonic flowmeter.



Energy calculator



Measurement of cold and heat with the WATERFLUX 3300



Electromagnetic flow measurement of hot water



EMF with paired temperature sensor



Concrete core temperature control



Flow measurement of natural gas for the humidifier

4. Customer benefits

The switch from gas and district heating to geothermal energy as the main energy source has already been able to significantly reduce the costs for externally purchased energy. This is also visible in the nominal diameters of the gas pipes which have been substantially reduced because of lower natural gas consumption by using geothermal energy, heat pump technology and a modern building with optimised energy management. In this way, KROHNE has contributed to decarbonising its own heating and air conditioning system.

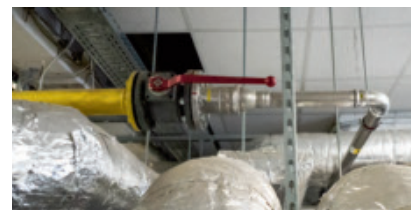

Natural gas pipeline with renewed, tapered piping on the right

The measurements enable KROHNE to further explore and realize even more potential optimisation of the heating and air conditioning system. In an ongoing process, based on the enhanced energy measurements, the company is now striving to bring the consumption and efficiency of the system ever closer to the ideal characteristic curve. Comprehensive energy data monitoring based on the measurement and calculation of flow rates and energy flows are key to monitoring and consistently reducing energy costs.

At KROHNE, all the values and measuring points can be viewed at any time via a monitoring system. Weekly evaluations provide a full overview of flow rates and energy consumption over time. In addition to regular reporting, critical operating states such as load peaks and conspicuous consumption profiles can be made visible at any time via real-time monitoring.

The monitoring system can also be used as an alarm system. Since it is also a building management system (BMS), the operating service is automatically informed in the event of malfunctions and conspicuous measurement deviations.

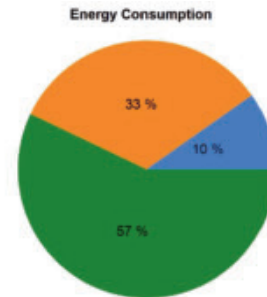
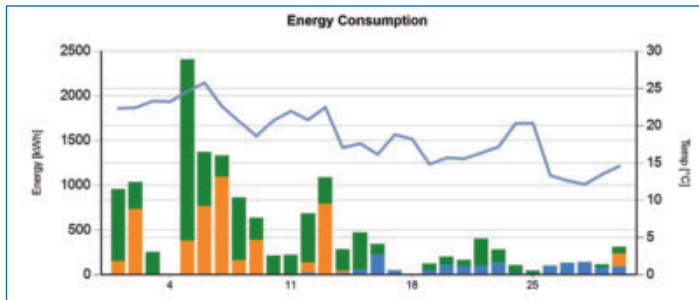

Data monitoring: evaluation of energy consumption (green = geothermal probe field / orange = heat pump / blue = recooling plant)

Saving resources in the long term is only possible if energy consumption is precisely measured and evaluated to make processes transparent. Companies that want sustainable energy management need to design their energy networks accordingly. KROHNE is a single source supplier of process instrumentation for certified flow technologies including ultrasonic, electromagnetic and others plus temperature sensors, level transmitters, pressure and differential pressure transmitters as well as energy calculators and flow computers.

The scope of supply goes far beyond standard applications for internal energy monitoring. We can also offer metrological consulting and project support, e.g. for the introduction of EMAS systems, and includes applications with measurements subject to billing and verification in transfer stations where the Measuring Instruments Directive applies.



Measurement of hot and cold with KROHNE electromagnetic flowmeters

5. Products used

WATERFLUX 3300

- Electromagnetic flowmeter for advanced water applications without straight inlet and outlet runs
- High accuracy ($\pm 0.2\%$) for water consumption measurement and distribution networks; approval according to MID MI-004 for heat/cold networks

OPTITEMP TRA-S12

- Resistance (RTD) temperature assembly for heat quantity measurements; available in paired version

OPTISONIC 7300

- Ultrasonic flowmeter for applications with natural gas, process gas and utility gas applications



Contact

Would you like further information about these or other applications?
Do you require technical advice for your application?
application@krohne.com

Please visit our website for a current list of all KROHNE contacts and addresses.





APPLICATION NOTE

Flow measurement of superheated steam for an absorption chiller

- Energy efficient use of excess heat from cogeneration to drive a chiller
- Integrated measurement of flow rate, pressure, temperature and energy in one device
- Accurate monitoring of thermal energy consumption at changing process conditions

1. Background

A utility company in Latvia operates several combined heat and power (CHP) plants to produce electricity and heat from wood chips and fuel gas. The energy supplier also operates various boiler houses and is responsible for the service and maintenance of a district heating network. For cost and sustainability reasons, and to comply with European carbon emissions regulations, the company uses the available energy sources as efficiently as possible. Among other things, the energy company uses by-product heat from cogeneration to drive an adjacent absorption chiller for cooling purposes.

2. Measurement requirements

Chillers are the system of choice for air conditioning, process fluid cooling or refrigeration in industrial sites and commercial buildings. The utility operates a single stage absorption chiller that is driven by low-pressure superheated steam recovered from the CHP process.

The steam provides an indirect thermal source in a three-phase cycle of evaporation, absorption and regeneration: As heat is removed from a coolant, a refrigerant (water) evaporates and is subsequently carried away by a liquid absorbent (lithium bromide) which chemically bonds to it. This diluted absorbent/refrigerant solution is transported to a generator. In the generator, the steam from the cogeneration process heats the diluted solution, causing the refrigerant to evaporate. As the absorbent is returned to the absorber, the refrigerant vapour undergoes a phase change in a condenser, allowing the cooling cycle to start all over again.

For balancing purposes and to assess the efficiency of the absorption chiller, the steam consumption needs to be measured. Depending on the amount of steam available, the flow rate of superheated steam varies over a wide range. It was equally important for the utility to avoid unnecessary efficiency losses and condensate formation. Therefore, the use of compact orifice plates was not an option.

KROHNE

3. KROHNE solution

The customer opted for a cost-effective yet versatile Vortex flowmeter with integrated temperature and energy calculator. The OPTISWIRL 4200 Vortex flowmeter is designed for energy measurements in steam applications up to +240°C / +464°F.

As superheated steam is used to drive the generator of the absorption chiller, the KROHNE flowmeter also has an additional built-in pressure sensor. This allows it to compensate for changing temperature and pressure conditions. With the IAPWS database integrated into the energy calculator, the Vortex flowmeter can directly output the gross heat mass flow of superheated steam. Due its measurement principle (Karman's law), the Vortex flowmeter offers a wide turndown ratio covering different operating conditions of the plant with good accuracy even at low flow rates. Vortex flow measurement is drift-free and only causes a negligible pressure drop.

Instead of calculating the net heat in the control room, the utility could also connect the temperature sensor installed in the condensate return line directly to the Vortex flowmeter. As the KROHNE flowmeter also has an input available for an external temperature sensor, it would be possible to measure the gross/net heat of steam in one device without using a separate flow computer.

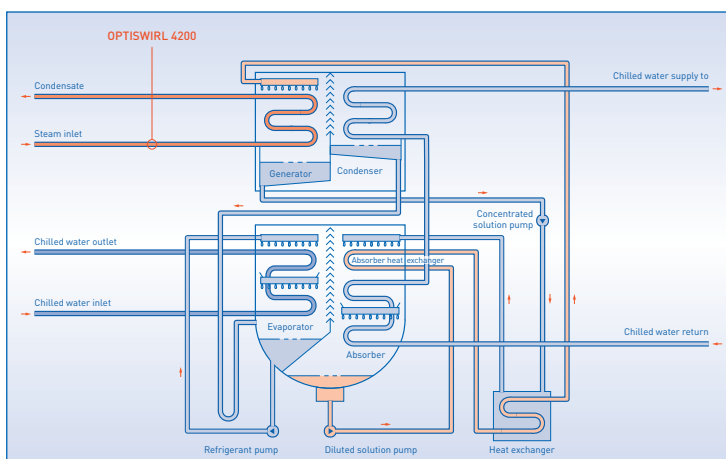

Simplified process scheme of absorption chiller with OPTISWIRL 4200

4. Customer benefits

Against the backdrop of increasingly stringent energy-saving regulations and rising cap-and-trade costs in Europe, the utility found an efficient way to use excess heat from cogeneration for year-round cooling purposes. There are no incremental emissions released by the absorption chiller.

KROHNE's Vortex flowmeter helps the customer monitor and balance the chiller's thermal energy consumption. The utility can use these readings to assess the efficiency of the absorption chiller over the long term and to better plan energy distribution. Unlike conventional Vortex flowmeters, the OPTISWIRL 4200 combines flow, temperature and pressure measurement as well as flow calculation in a single device. This can save approximately 45% of installation costs and results in a better overall system accuracy.

The Vortex flowmeter is designed for advanced energy management systems as it can be supplied with integrated gross and net heat measurement for steam and condensate. Whether cooling or heating applications in industrial plants, data centres, university campuses, hospitals, hotels or large commercial office buildings: For companies that want to implement sustainable energy management and need to design their energy networks accordingly, KROHNE offers all the necessary and certified process instrumentation from a single source, including consulting and project support.

5. Product used

OPTISWIRL 4200

- Vortex flowmeter for utility applications and energy management systems
- For liquids, (wet) gases, saturated and superheated steam (+240°C / +464°F)
- Integrated P+T measurement: direct output of mass, nominal flow, energy, gross/net heat

Contact

Would you like further information about these or other applications?
Do you require technical advice for your application?
application@krohne.com

Please visit our website for a current list of all KROHNE contacts and addresses.





APPLICATION REPORT

Heat metering at a transfer station of a district heating pipeline

- Process instrumentation for the sustainable use of thermal energy from a waste-to-energy plant
- Monitoring of flow, pressure and temperature in an energy transfer station
- Complete solution from a single source for accurate billing of heat in accordance with MI-004, Class 1

1. Background

Vestforbrænding is Denmark's largest waste management company. It provides waste disposal and treatment services to 19 municipalities in Greater Copenhagen and North Zealand. The utility also uses the energy from waste incineration to generate electricity and feeds eco-friendly thermal energy into the district heating network.

2. Measurement requirements

Having taken over a district heating pipeline, the utility needed to manage the heat transfer to the district heating network of energy supplier Norfors. The heat quantities provided must therefore be determined and billed accordingly. This required the use of process instrumentation approved for heat metering in accordance with the standards of the Measuring Instruments Directive (MID) MI-004 (2014/32/EU, Annex VI).

As the heat transfer station is in a nature conservation area, the installation was to be placed almost exclusively underground. Together with the responsible environmental protection authority, the district heating network operators agreed on the construction of an underground measuring station by means of a special permit. The manhole was designed for two pipes (feed and return) in nominal size DN250 and specified for a maximum pressure of 40 barg / 580 psig and a process temperature of +110°C / +230°F.

3. KROHNE solution

The utility qualified Fagerberg as a partner for the instrumentation and control engineering. KROHNE's sales and service partner responsible for Denmark has put together a complete solution for the underground metering station according to the customer's requirements – from process instrumentation to the flow computer. As the customer wanted the highest possible accuracy for heat metering, Fagerberg recommended using the OPTISONIC 3400 District Heating ultrasonic flowmeter in both the feed and return lines. The KROHNE device is certified according to MI-004, Class 1, and is thus one of the few measuring devices of its kind on the market to meet the highest accuracy requirement for thermal energy measurement.

KROHNE

The 3-path ultrasonic flowmeter has a full-bore design without any obstructions, operates without pressure loss and is insensitive to magnetite scaling. It measures with long-term stability over a wide dynamic range and is also ideally suited for measuring conditioned, low-conductivity water, often used to feed district heating networks.

The OPTISONIC 3400 District Heating is designed for heat energy measurement and functions as a heat meter in combination with temperature sensors and an energy calculator. To this end, four paired OPTITEMP TRA-T30 temperature sensors were installed in each heat transfer pipe. The weld-in resistance temperature assembly (RTD) has a tapered barstock thermowell very well suited for demanding district heating applications with higher pressures and flow rates. An energy calculator then calculates the supplied and consumed thermal energy based on all readings.



District heating measurement with OPTISONIC 3400 District Heating flowmeter, OPTITEMP TRA-T30 temperature sensor and OPTIBAR PM 3050 pressure transmitter

In addition, the customer uses the OPTIBAR PM 3050 pressure transmitter in the feed and return lines. Pressure serves as a control parameter since the pumps in the heating network are controlled depending on the heat demand to keep energy use as low as possible. This allows load flexibility in correlation with the flow rate, i.e. in case of reduced heat consumption. The compact pressure transmitter comes with a fully welded stainless-steel construction featuring high overload resistance as required in this application.

4. Customer benefits

Thanks to the tailored combination of all the necessary components – incl. averaged temperature measurement from four measuring points as well as flow measurement acc. to class 1 – Vestforbrænding has a MI-004 approved district heating transfer station. Billing of thermal energy supplied to Norfors via the district heating pipeline can now be done in accordance with the legal framework. All components have been conformity assessed and were supplied calibrated. The flow measurement in the feed and return lines also enables the customer to balance the volume flow rate and thus to operate integrity or leakage monitoring. The pressure measurements serve to control the performance of the pumps according to demand and reduce energy consumption to a minimum.

KROHNE offers process instrumentation for energy measurements in heat transport pipelines, transfer stations, substations and pumping stations for district heating through a worldwide network of sub-sidiaries and sales partners such as Fagerberg. This includes the supply of certified flowmeters and other instrumentation as well as energy calculation. In addition, the corresponding services such as calibrations according to module D or F as well as the legally required maintenance are also an essential part of this complete package for energy measurements, which KROHNE offers from a single source.

5. Products used

OPTISONIC 3400 District Heating

- Ultrasonic flowmeter for district heating applications
- 3-path meter for thermal energy measurement and heated water
- Approvals: MID MI-004 (Class 1, 2, 3), OIML R75

OPTITEMP TRA-T30

- Resistance (RTD) temperature assembly for higher flow velocities and pressures

OPTIBAR PM 3050

- Pressure transmitter for general pressure and level applications

Contact

Would you like further information about these or other applications?

Do you require technical advice for your application?

application@krohne.com

Please visit our website for a current list of all KROHNE contacts and addresses.





APPLICATION NOTE

Custody transfer (CT) flow measurement for a natural gas fuel system

- Flow metering solution for gas supply to load-flexible combined cycle gas turbine (CCGT) units
- Equipping fuel skids with calibrated metering sections and flow computers
- Maintenance-free operation and long-term stable, repeatable flow measurement using ultrasonic gas flowmeters
- Complete flow solution from one source: from engineering, instrumentation and flow computing to certification and commissioning

1. Background

Combined cycle gas turbine (CCGT) plants are clean, highly efficient and thanks to their load flexibility vital to stabilizing electricity grids fed with renewable energies. To provide their clients with reliable and stable electricity, a US electricity supplier operates an 800 MWel power station utilizing three CCGT units with heat recovery steam generators (HRSG). Each plant unit is equipped with an individual fuel gas pressure regulating and metering skid.

2. Measurement requirements

The main fuel gas consumers at CCGT plants are the gas turbines and the duct burners. The load rate of the plants can change quickly, resulting in a rapid change of fuel gas flow rate. For the feedlines to the three CCGT units, fuel systems perform a wide range of tasks, such as separation, fuel gas conditioning, pressure reduction (from 660 psi /45 bar to 64 psi / 4.4 bar) as well as custody transfer (CT) flow measurement and safety functions.

To measure fuel gas consumption, the customer had previously used turbine meters. Having been unsatisfied with the meter performance and maintenance requirements, the company started looking for a more reliable and accurate solution. The electricity supplier needed a complete natural gas flow solution as part of their fuel system to increase accuracy and plant availability as well as to reduce maintenance efforts. The solution was required to meet the local CT regulations according to AGA 9 as well as the regulations stipulated by the grid operator.

3. KROHNE solution

KROHNE supplied a metering solution consisting of three calibrated metering sections, pre-assembled and equipped with ALTOSONIC V12 ultrasonic gas flowmeters (UFM), pressure and temperature transmitters, certified SUMMIT 8800 flow computers and associated pipework. Engineering, related test documentation and final commissioning of the ready-to-operate solution has also been provided by KROHNE.

As a core element, three 8" ALTOSONIC V12 were installed for flow measurement of up to 2500 MSCFH of natural gas. The 12-chord ultrasonic CT gas flowmeter complies with multiple standards such as AGA 9, OIML R137, MI-002. It was the first ultrasonic flowmeter to be certified according to OIML R137 class 0.5 by a national metrology institute. Due to its unique ultrasonic path arrangement, the KROHNE flowmeter can compensate flow profile disturbances caused by restricted installation space much better than any other commercially available ultrasonic flowmeter in this category. There are also no moving or rotating parts and its sophisticated diagnostic options monitor the meter integrity and issue a warning in the event of fouling or condensate formation. The gas flowmeter features fast response and is able to cope with transient flow conditions without having any lifetime limitations.



Gas fuel skids with ALTOSONIC V12 ultrasonic gas flowmeters



SUMMIT 8800 flow computer



Custody transfer flow measurement of natural gas

4. Customer benefits

The electricity company operates their CCGT power plant units at high efficiencies and flexible loads. The KROHNE flow solution based on the ALTOSONIC V12 ultrasonic flowmeter supports in keeping efficiencies and plant uptime at high levels.

KROHNE provided the complete flow solution including engineering, instrumentation, pipe sections, flow computers, accessories, drawings, test documentation, certificates and commissioning. As a full solution provider, KROHNE can supply complete systems such as fuel systems for the supply of CCGT power plants, duct burners, air heaters or process heaters.

5. Solutions and products used

Custody transfer metering systems for gases

- Metering solution for natural gas
- Comprising flow metering skid, metering control cabinets, sampling and analyser systems, and all supervisory and validation software

Flow computing

- Flow computer solution for the visualisation of measurements

ALTOSONIC V12

- Ultrasonic flowmeter for custody transfer (CT) measurement of gases
- CT: OIML R137 (class 0.5), MI-002, AGA9 etc

SUMMIT 8800

- Flow computer for custody transfer (CT) measurement



Contact

Would you like further information about these or other applications?
Do you require technical advice for your application?
application@krohne.com

Please visit our website for a current list of all KROHNE contacts and addresses.





APPLICATION REPORT

Flow measurement of green hydrogen at a power-2-gas plant (P2G)

- Accurate and consistent information for the grid injection of green gases
- Flow measurement of hydrogen, synthetic methane (SNG), carbon dioxide and natural gas
- Full scope of delivery from one source incl. instrumentation, testing, commissioning and training



1. Background

GRTgaz is one of the leading European operators in natural gas transmission. The company is an innovator in the area of sustainable energy production and distribution. GRTgaz is the project coordinator of the Jupiter 1000 project (www.jupiter1000.eu), which is France's first industrial power-2-gas (P2G) demonstrator with injection into the gas grid, located in Fos-sur-Mer in southern France. This project was supported in particular by the French Agency for Ecological Transition (ADEME), the European Regional Development Fund (ERDF) as well as the administrative region of Provence-Alpes-Côte d'Azur and has been awarded by the Investments for the Future (PIA) programme of the French government.

P2G is a technology that uses electrical power to produce gaseous fuels. In the Jupiter 1000 project, renewable energy is used to produce hydrogen by means of electrolysis of water. This green hydrogen can be applied either as a fuel, an energy carrier or as feedstock, and will play an important role in de-carbonizing the industry and energy sector. In the Jupiter 1000 project the produced green hydrogen is applied in two different ways to de-carbonize the natural gas supply. In the first method the hydrogen is directly injected in the grid and forms a blend of hydrogen and natural gas. In the second method the hydrogen (H_2) is converted into synthetic methane (CH_4) via the methanation process in which it reacts with CO_2 captured at a nearby industrial site. Subsequently the synthetic methane is injected in the natural gas grid.

2. Measurement requirements

JUPITER 1000 is a demonstrator P2G project which combines two electrolysis technologies: PEM (membrane) and alkaline (liquid). In cooperation with several industrial partners, performance tests and plant optimisation analyses are carried out for a minimum of three years. To assess the technical and economic feasibility of injecting H₂ and synthetic CH₄ into the existing gas networks, knowledge about the composition of the products and the efficiency of the different electrolysis processes is of the essence. Therefore, GRTgaz requests accurate, clear and consistent information about the flow rates and compositions of the various gases. Furthermore, low costs of maintenance and operation (OPEX) are required.

3. KROHNE solution

As a main instrument vendor (MIV) and solution provider to the gas industry, KROHNE has designed, built and delivered a tailored package to the customer, including flow metering and flow computing. The process integration, commissioning and on-site training has been provided as well. The measurement of all essential process flows has been covered:

Mass flow measurement of **green hydrogen** from electrolysis and **synthetic natural gas (SNG)** from the methanation process:

- 2 x OPTIMASS 6400 C Coriolis mass flowmeters (½" with 600 lb flanges), ATEX Ex ia certified

Volume flow measurement of **carbon dioxide** captured from industrial flue gases:

- 1 x OPTISWIRL 4200 C Vortex flowmeter with integrated pressure and temperature compensation as well as built-in flow computer for flow calculation to standard conditions; Certified acc. to ATEX Ex ia

Volume flow measurement of **natural gas** from the network:

- 2 x OPTISONIC 7300 C ultrasonic flowmeters (4" and 6" with 600 lbs flanges), ATEX Ex ia certified



Flow measurement of hydrogen and SNG with the OPTIMASS 6400



OPTISONIC 7300 ultrasonic flowmeter prior to commissioning

All flowmeters are integrated into the existing project infrastructure with its control valves, pumps and gas analysers. The flowmeters for SNG, hydrogen and natural gas are connected to one single SUMMIT 8800 flow computer which enables the customer to set up all four flowmeters independently and without the need for additional KROHNE field service. The highly versatile flow computer is dedicated to the energy calculation of various products and conditions. It comes with Modbus communication protocol (RS 485) as per customer requirement.

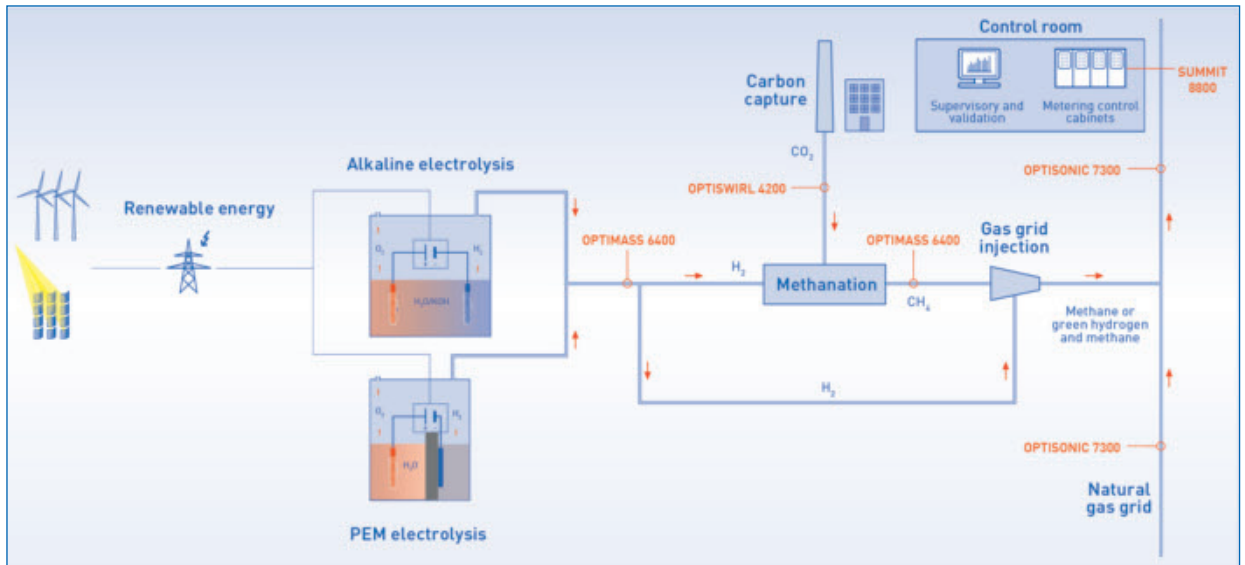

Process flow sheet of Jupiter 1000 P2G project with measurement points

4. Customer benefits

The customer benefits from significantly lower operating costs for the accurate and reliable flow measurement and energy calculation of the produced and transported gases. Maintenance is minimized as the meters have no moving parts. Since the full bore OPTISONIC 7300 is in use, the pressure loss (typically associated with turbine meters) has been minimized, saving on costs for pump and compressor capacities.

Not only OPEX, but also CAPEX has decreased. In fact, there is no need to equip each flowmeter for H₂ and CH₄ with its own flow computer any more, as was the case with the previously used turbine meters and clamp-on devices. The SUMMIT 8800 flow computer is multifunctional and can process the measured values of several meter types simultaneously. The KROHNE project team managed the whole delivery of the complete solution from design to Factory Acceptance Test (FAT) and field integration. By providing all this from one single source, KROHNE fully met the expectations of the customer.



KROHNE Coriolis mass flowmeters installed at P2G demonstrator



SUMMIT 8800 flow computer in control cabinet



OPTISONIC 7300 C: Ultrasonic flow measurement of natural gas from the grid

5. Products used

OPTIMASS 6400 C

- Coriolis mass flowmeter for advanced process applications with hydrogen and other gases and liquids
- Custody transfer: OIML R117, R137, MI-002, MI-005; API, AGA, etc.
- Flange: DN10...300 / ½...12", max. PN 160 / ASME Cl 1500
- SIL 2/3 certification acc. to IEC 61508-2010, up to DN200 / 8"



OPTISONIC 7300 C

- Ultrasonic flowmeter for natural gas, process gas and utility gas applications
- 2-path meter, for standard volume flow metering, independent of media properties
- No maintenance, no pressure loss, large dynamic range
- Flange: DN50...1000 / 2...40", max. PN450 / ASME Cl 2500; also weld-in connections



OPTISWIRL 4200 C

- Vortex flowmeter for utility applications and energy management systems
- For liquids, (wet) gases, saturated and superheated steam (+240°C / +464°F)
- Integrated P+T measurement: direct output of mass, nominal flow, energy, gross/net heat
- Flange: DN15...300 / ½...12"; wafer version: max. DN100 / 4"



SUMMIT 8800

- Flow computer for visualisation of measurements, managing multiple measured values of several meter types simultaneously
- Compliant with all main international standards, such as OIML, ISO, API, AGA, GOST
- Cost effective solution due to modular hard- and software design
- Full colour graphical touch screen for maximum process transparency



Contact

Would you like further information about these or other applications?
Do you require technical advice for your application?
application@krohne.com

Please visit our website for a current list of all KROHNE contacts and addresses.





APPLICATION REPORT

Equipping a biomass plant with process instrumentation for billing steam quantities

- Compliance with all metrological requirements for subsidies and feed-in tariffs in accordance with the Combined Heat and Power Act
- Traceably calibrated meter runs for precise calculation of thermal energy
- Full scope of delivery from one source – from instrumentation to documentation to calibration and commissioning



1. Background

The Industrial Park Kleefse Waard (IPKW) in Arnhem, the Netherlands, was once an important production site for cellulose and nitrocellulose. Today, the industrial complex is home to manufacturing companies from various sectors and has become a pioneer in the sustainable production and use of energy. The operating company has set itself the goal of making the IPKW the most environmentally friendly industrial site in the Netherlands. To this end, the operator is investing in the expansion of renewable energy generation at the site.



Historic boiler house with new biomass boiler in the Industrial Park Kleefse Waard (IPKW)

Stork Thermeq, a leading global solution provider for steam generation and heat recovery in industrial plants, was commissioned to build a new biomass cogeneration plant. The cogeneration plant will supply sustainably produced heat and electricity to the companies in the industrial park and will also supply households in the city of Arnhem via the district heating network.

Cogeneration – the combined production of heat and power (short: CHP) – is considered particularly sustainable. The plant is therefore in principle eligible for promotion under the national Combined Heat and Power Act (CHP Act). The heat and electricity generated by cogeneration is also subsidised by feed-in tariffs.



2. Measurement requirements

Stork Thermeq turned the existing boiler plant into a state-of-the-art biomass-fired CHP plant. Due to the high demand for steam for the district heating network, the CHP has been equipped with a back-pressure turbine. The high-pressure steam flow produced by the boiler is split into two streams. One stream of high-pressure steam is supplied to the industrial enterprises within the industrial park, and the other stream is used for electricity production via a back-pressure turbine. The remaining heat in the low-pressure steam from the turbine is then further utilized in the district heating network.

In terms of measurement, the plant must be designed in a way that the operator can bill the process steam consumed by the industrial estate’s customers. In addition, the sustainably produced energy (electricity and steam) is subject to verification as soon as the state subsidies and feed-in tariffs are claimed. It must be accounted for that only heat and electricity from CHP plants can be invoiced. Biomass CHP must therefore also be strictly separated metrologically from other plant components (e.g. auxiliary boilers and other heat sources) that are not part of sustainable energy production.

The measurement of the energy flows is carried out in accordance with the Measuring Instruments Directive (MID) and the applicable calibration law. This applies, for example, to the billing of hot water (MI-004/ OIML R-117). However, not all media are defined in the MID. For the billing of heat energy (steam) no valid calibration law applies. For the metrological design of measuring points, the best available technology is to be considered here. Appropriate measuring procedures are to be used to ensure the highest possible accuracy. Among others, this requires the measuring instruments to be traceably calibrated.

Stork Thermeq required instrumentation for process control and for billing and verification purposes for several measuring points. Particular attention was paid to steam measurements. The measurement technology had to be accurate in accordance with the ISO 5167 standard and generate only low residual pressure loss.

Medium	Steam
Flow velocity	14 m/s
Density	17.8 kg/m ³
Pressure	56 bar / 812 psi
Temperature	+450°C / +842°F

3. KROHNE solution

As a main instrumentation vendor (MIV) with many years of industrial experience in the power plant sector as well as in custody transfer and billing applications, KROHNE was able to qualify as a partner in this project. KROHNE supplied a complete solution made up of flow, pressure, and temperature measurement instrumentation as well as a flow computer. This package also included design and sizing, as well as documentation and calibration in accordance with the Dutch Power and Heat Act. The complete package focused on the following four measuring points:

3.1 Feedwater measurement

For feedwater measurement, KROHNE supplied the OPTISONIC 3400 ultrasonic flowmeter with remote field-mounted signal converter (F). The flowmeter monitors the amount of feedwater used for the biomass-fired steam boiler. Additionally, the OPTIBAR PM 3050 pressure transmitter and the OPTITEMP TRA-S34 temperature assembly have been installed. This enables the energy content (enthalpy) of the feedwater to be determined in addition to the volume flow rate. The readings are then transmitted to the SUMMIT 8800 flow computer. These measured values serve as important parameters for adjusting the performance of the plant as required. In addition, they prove the amount of feedwater used for cogeneration and enable a clear and consistent separation from the process of the conventionally fired auxiliary boiler.



Feedwater measurement with the OPTISONIC 3400 ultrasonic flowmeter

3.2. Flow measurement of process steam

In order for the operator to bill process steam quantities used, KROHNE supplied a meter run calibrated according to ISO 5167. This consists of a Venturi nozzle with annular chamber as primary element, including a forged 5-way manifold and process valves. The flow rate is measured by the OPTIBAR DP 7060 differential pressure transmitter, which in this application has a differential pressure measuring range of up to 500 mbar with an overload protection up to 160 bar.

KROHNE carried out the calibration on a traceable calibration facility using the same Reynolds numbers prevalent in the real process. The OPTIBAR DP 7060 was 3D linearised at the factory over the entire range of static pressure and ambient temperature. Typically, high line pressures and increased ambient temperatures have virtually no influence on the measurement uncertainty. In addition, the measuring point was equipped with the OPTIBAR PM 3050 pressure transmitter for gauge pressure measurement as well as the OPTITEMP TRA-S34 temperature assembly. This enables the operator to carry out a pressure and temperature-compensated mass measurement and additionally determine the thermal energy (enthalpy). All measured values are transmitted to the SUMMIT 8800 flow computer approved for custody transfer measurements.



OPTIBAR DP 7060 (centre) as well as gauge pressure measurement with the OPTIBAR PM 3050 (left)

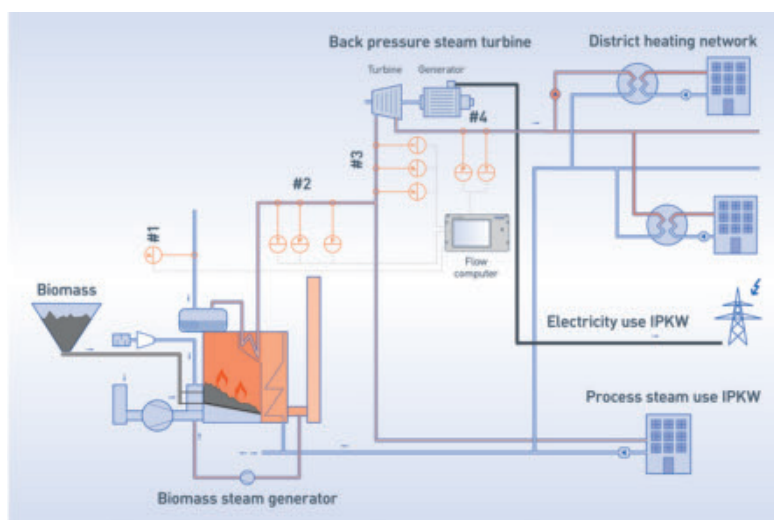

- #1 Feedwater measurement
- #2 Flow measurement of process steam
- #3 Flow measurement in the steam line to the back-pressure turbine
- #4 Feed-in measurement of steam for district heating



Calibrated meter run with Venturi nozzle, OPTIBAR DP 7060, OPTIBAR PM 3050 and OPTITEMP TRA-S34

3.3 Flow measurement in the steam line to the back-pressure turbine

Another traceably calibrated meter run with the same instrumentation was installed in the steam line supplying the back-pressure turbine. The measured values are again processed by the SUMMIT 8800. The energy quantity of this measuring point is offset against the energy quantity of the previous measuring point, so that the individual steam flows can be recorded exactly separated from each other.

3.4 Feed-in measurement for district heating

In order to bill the energy fed into the district heating network, the existing flow measurement into the turbine is combined with the enthalpy of the condensate measured at this point. The measuring point is equipped with the OPTIBAR DP 3050 pressure transmitter and the OPTITEMP TRA-S34 temperature assembly. The SUMMIT 8800 calculates the energy with the flow measurement readings of the turbine feed and precisely determines the energy flow provided to the district heating network.



Venturi nozzle installation



Temperature measurement with the OPTITEMP TRA-S34

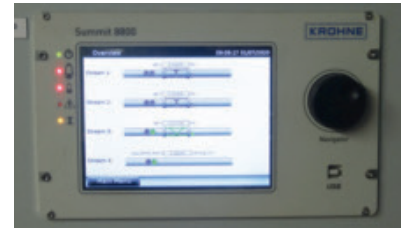

SUMMIT 8800 flow computer displaying the measurements of steam and feedwater

4. Customer benefits

The traceably calibrated meter runs reduce the installation effects on the measurement to a minimum, so that the energy flows are measured accurately and in accordance with the legal requirements. In this way, the operator complies with all requirements, both for the billing of steam quantities and for state subsidies and feed-in tariffs.

In addition to the hardware and the corresponding instrumentation, KROHNE supplied the full scope of services required – from engineering, documentation and material certification to calibration and commissioning on site. Stork Thermeq and the operating company equally benefited from a comprehensive tailored solution, which KROHNE was able to deliver from a single source, thanks to its process knowledge and years of experience in custody transfer and calibration.

KROHNE can provide the appropriate flowmeter technology for all Power and Heat Act related applications like steam, feedwater, condensate, fuel gas, etc. e.g. measurements in district heating networks according to MID MI-004 (accuracy class 1).

5. Products used

Venturi nozzle

- Engineered primary element according to standard (ISO 5167)
- For high accuracy flow measurement at low residual pressure loss

OPTIBAR DP 7060

- High performance DP transmitter with integrated line pressure measurement
- For advanced flow measurement in combination with primary elements

OPTIBAR PM 3050

- Compact pressure transmitter for pressure and level applications

OPTISONIC 3400

- Ultrasonic flowmeter for feedwater and other liquids

OPTITEMP TRA-S34

- Threaded RTD temperature assembly for use in existing thermowells

SUMMIT 8800

- Flow computer for custody transfer (CT) measurement



Contact

Would you like further information about these or other applications?
Do you require technical advice for your application?
application@krohne.com

Please visit our website for a current list of all KROHNE contacts and addresses.





Oil & Gas

- Flow measurement for billing of a hydrogen/natural gas mixture..... 28
- Upgrading gas receival stations with standardized electrical cabinets..... 30
- Leak detection on a CO₂ pipeline..... 32
- Monitoring energy consumption at an oil and gas field..... 34



APPLICATION REPORT

Flow measurement for billing of a hydrogen/natural gas mixture

- Custody transfer flow measurement of a gas mixture with hydrogen (H₂) and methane (CH₄)
- Re-use of existing natural gas pipeline for H₂ transport between industrial sites
- Decrease in energy consumption of 0.15 PJ, 10,000 metric tons CO₂ per year saved

1. Background

In their effort to achieve a climate neutral industry, Dow Benelux is an active partner in the Smart Delta Resources (SDR) partnership in a collaboration with other companies in the Flemish-Dutch Schelde-Delta. One project of this initiative comprises the supply of hydrogen produced in Dow's cracking plants. In this way, the hydrogen is made available as a raw material for other industrial sites in the region, following the "Green Deal on Hydrogen" that was signed for the region in 2016.

2. Measurement requirements

As an efficient, safe and sustainable way of hydrogen transportation, a previously existing 12 km / 7.4 mi long underground transport pipeline for natural gas has been reinstated for hydrogen supply. Around 4 kilotons of H₂ can be provided every year as part of a gas mixture of hydrogen and methane. This allows energy consumption costs to be initially cut by 0.15 petajoules (PJ) per year or roughly the annual gas consumption of 3,000 households, which in turn translates into a reduction in carbon emissions of 10,000 metric tons. And there is still future potential for further emission cuts.

As the gas measurement is subject to billing between buyer and producer, a certified and calibrated custody transfer flowmeter was required for the pipeline. Given that hydrogen has an 8 times lower density than natural gas, the process instrument had to be designed accordingly and supplied with gaskets and fittings in line with these requirements. The pipeline is operated around 30 bar / 435 psi. To keep operational costs at a minimum, pressure loss of the flowmeter was demanded to be as low as possible. It was also of the essence that the flowmeter featured enhanced diagnostics for predictive maintenance.

3. KROHNE solution

As an experienced vendor of process instrumentation for custody transfer flow measurement of gases and gas mixtures with up to 100% hydrogen, KROHNE became the preferred supplier in this project. The ALTOSONIC V12 ultrasonic gas flowmeter turned out to be the flowmeter of choice for this hydrogen application. This KROHNE device is a 12-chord ultrasonic gas flowmeter for custody transfer (CT) of natural gas, hydrogen, or different gas mixtures. It was in fact the first ultrasonic gas flowmeter to achieve the OIML R137 Class 0.5. The flowmeter met the essential requirements of the client in terms of custody transfer approvals, wetted materials, extensive diagnostic features, calibration, and pressure loss.

The ALTOSONIC V12 was installed as a 6" insulated meter into the hydrogen/methane transfer pipeline that was previously in use for natural gas. Offering a wide range of ultrasonic transducer materials, KROHNE recommended the epoxy-based version. This transducer type perfectly fits applications with hydrogen as it provides excellent acoustic features and is not prone to hydrogen embrittlement at elevated temperatures as compared to titanium transducers. The gas flowmeter comes with enhanced diagnostics. Among others, it features a vertical diagnostic path that detects contamination on the bottom of the measuring tube (bottom-fouling detection). In this way, it can give a precise view into the flowmeter, allowing the client to carry out predictive maintenance.

In close cooperation with a calibration lab, KROHNE also solved the challenge associated with custody transfer calibration procedures for hydrogen applications. As there has not been any commercial lab for calibration of flowmeters with hydrogen so far, a similar Reynolds number range was selected at the lab to get as close as possible to operational conditions. The H₂/CH₄ ratio required a 3 times lower pressure to be used in the lab as compared to operational conditions. The meter has been calibrated at six flow rates and is certified according to MID-002.

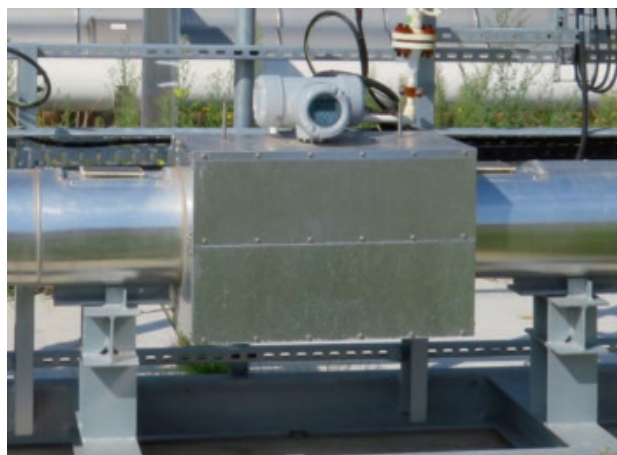

MID certified ultrasonic custody transfer flow measurement of a hydrogen/methane mixture

4. Customer benefits

The client benefits from reliable and accurate custody transfer flow measurement in accordance with the MID MI-002. The transport and supply of the hydrogen/methane mixture can now be properly invoiced and billed. Thanks to its diagnostic path to detect contamination, the reliable and accurate KROHNE flowmeter enables self-monitoring, making process optimization possible.

5. Product used

ALTOSONIC V12

- Ultrasonic flowmeter for custody transfer (CT) measurement of gases
- 12-chord meter, for high accuracy flow metering
- CT: OIML R137 (class 0.5), MI-002, AGA9 etc.
- Many variants, extensive CBM diagnostics free of charge
- Flange: DN100...1600 / 4...64"; max. PN450 / ASME Cl 2500



Contact

Would you like further information about these or other applications?
Do you require technical advice for your application?
application@krohne.com

Please visit our website for a current list of all KROHNE contacts and addresses.



www.krohne.com



APPLICATION REPORT

Upgrading gas receival stations with standardized electrical cabinets

- Replacing electronic volume converters with modular MI-002 flow computer cabinets
- Cost-effective flow control and data transfer cabinets for a future-proof pipeline network
- Ready for alternative gas mixtures, e.g. natural gas and hydrogen mixtures
- Reduced installation costs at minimum downtime: Up and running within one day



1. Background

Gasunie is a gas infrastructure and transport company with a pipeline network of over 15,000 km in length in the Netherlands and Germany. With a throughput of approximately 125 billion m³ per year, it is one of the most extensive high-pressure networks in Europe. Gasunie Transport Services (GTS) is the subsidiary that manages the Dutch part of the Gasunie network.

2. Measurement requirements

To upgrade their metering systems and replace the EVCD (Electronic Volume Conversion Device) in part of their 1200 custody transfer gas receival stations, mainly city gates, GTS was looking for a tailored, cost-effective MI-002 approved solution. The solution was to be equipped with standardized components, refraining from superfluous hardware to minimize on costs for spare parts and service training as well as to keep installation costs and downtime to a minimum.

Further key design requirements for this solution included:

- Modularity: to accommodate 2, 3 and 4 flow streams per cabinet
- Flexibility: to allow for alternative gas compositions, e.g. biogas and hydrogen-injected natural gas
- Ethernet communication capability and smart meter connectivity
- Ease of verification and periodical recalibration of the entire metering system



Gasunie infrastructure in the Netherlands



3. KROHNE solution

Based on a European tender, GTS selected KROHNE to upgrade their EVCDs. To minimize on-site installation work and downtime, KROHNE, in close co-operation with GTS, designed a standardized, modular data transfer cabinet with the SUMMIT 8800 flow computer as its core element.

The full-color touch screen of the flow computer shows a graphical representation of all key instrumentation and important measurement data. Since each metering stream runs on a dedicated electronics board slotted in the back of the SUMMIT 8800, it resulted in a cost-effective solution, avoiding unnecessary hardware.

Each cabinet has been equipped with an identical 230V power supply, input and output barriers, connection terminals and a fuse box. The only variable is the number of metering streams that can be connected. Due to the modular set-up, each cabinet supports 2, 3 or 4 streams.

In the front panel a USB key has been integrated which is used for periodical verification and calibration of e.g. pressure and temperature transmitters. The transmitters are connected to a dedicated calibration device that via the USB port automatically reads the calibration results directly from the flow computer. This means calibration is far less time-consuming and there is less room for error as compared to entering calibration values manually, which is no longer required.

The cabinets have been produced in small series. They were fully pre-programmed and tested prior to installation on site. As a result, the total downtime for decommissioning the previously existing cabinets has been minimized. Each new KROHNE cabinet has been installed in less than 4 hours. After installation, the cabinets were directly sealed as per MID MI-002, using KROHNE's module B and D approval.

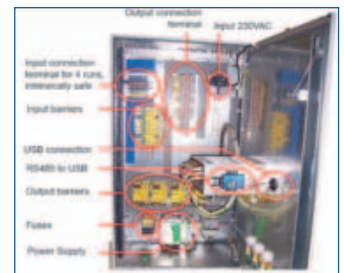

Inside of a control cabinet with SUMMIT 8800 flow computer



Flow computer manufacturing at KROHNE in Breda, the Netherlands



KROHNE control cabinets ready for shipping

4. Customer benefits

The standardised flow computer and data communication cabinets offered GTS a cost-effective solution to upgrade their gas receival stations. The similar design of the cabinets means minimised spare parts and less operator training required. Having been equipped with state-of-the-art digital communication and made ready for alternative gas mixtures and hydrogen, the cabinets helped the customer make their pipeline network future proof. As an experienced solution provider to the oil and gas industry, KROHNE covered the whole design, manufacturing and testing process including approval management, delivering the control cabinets and flow computing equipment from one source.

5. Solution and product used

Modular flow control and data transfer cabinets

- Cost-effective, modular metering control solution
- Fully wired, preconfigured and tested
- Engineered to customer specification (incl. CT approvals etc.)

SUMMIT 8800

- Flow computer for custody transfer (CT) measurement

Contact

Would you like further information about these or other applications?
Do you require technical advice for your application?
application@krohne.com

Please visit our website for a current list of all KROHNE contacts and addresses.





APPLICATION NOTE

Leak detection on a CO₂ pipeline

- CO₂ is removed from natural gas prior to LNG liquefaction
- A 7 km / 4.35 mi pipeline transports the CO₂ to injection wells for permanent storage
- An E-RTTM based pipeline leak detection system is installed on this pipeline

1. Background

Natural gas from the Gorgon gas field in Western Australia contains around 14% naturally occurring CO₂. Prior to converting the natural gas to LNG by cooling it to -162°C / -259.6°F, the CO₂ is removed. To minimize the environmental footprint, the separated CO₂ is not vented but injected in a storage formation. A 7 km long underground pipeline transports the CO₂ from the LNG liquefaction plant to the CO₂ injection wells.

2. Measurement requirements

The CO₂ is transported in supercritical phase at elevated pressures. The underground pipeline has a diameter of 300 mm / 12". Three compressor modules feed CO₂ in the pipeline that transports it to nine injection wells at three drill centers. The measurement requirement for this project was to provide a pipeline leak detection system that provides timely and accurate leak information for the three pipeline-segments between the LNG plant and drill-centers.



Construction of a pipeline

3. KROHNE solution

KROHNE provided their PipePatrol E-RTTM based leak detection system. Based on flow, pressure and temperature measurement at inlet and outlet of the pipeline, and a digital twin of the pipeline, PipePatrol calculates the flow, pressure and temperature at any given position in the pipeline, using Real Time Transient Modelling.

In case calculated flow, pressure and temperature start to deviate from actual measured value, a proprietary algorithm developed to avoid false alarms, is used to distinguish between a sensor drift and a true leak. The project involved unique conditions, such as the specific thermophysical properties of CO₂ in the supercritical phase and the flow measurements done by orifice plates with a limited rangeability. Still the minimum detectable leak rate in this project is around 1% with a detection time of less than 15 minutes.

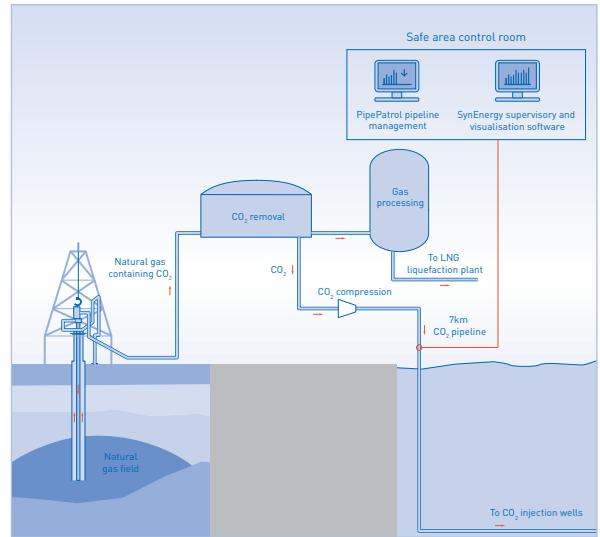

Process scheme: Pipeline leak detection on a CO₂ pipeline from LNG plant

A simulated leak test was done under 3rd party review of Lloyds. The test was carried out by offsetting the reading in the SCADA system by one of the flowmeters with 10 kg/s, resulting in a swift leak alarm from PipePatrol.

KROHNE's SynEnergy III supervisory software has been used for interfacing with the existing SCADA systems and creation of the leak detection HMIs. Running on a virtual server inside the company network, the HMI screens are accessible from anywhere in the network.

4. Customer benefits

A pipeline leak detection system based on E-RTTM supports the safe management of the CO₂ transport pipeline's operations. In case of a leak, whether spontaneous or a small creeping leak, PipePatrol will alarm the customer accordingly.



PipePatrol HMI screen

5. Solutions used

PipePatrol Leak Detection

- Solution for pipeline leak detection and localisation
- Based on E-RTTM (Extended Real Time Transient Model)
- Highly accurate and extremely reliable leak information
- Meets API 1130, API 1175, AB 864, German TRFL standards and CSA Z662
- Independent system or integrated with existing systems

SynEnergy Supervisory and visualisation software

- Solution for continuous process monitoring and reporting
- HMI/SCADA software for measurement solutions
- Easy integration into existing DCS and ERP networks

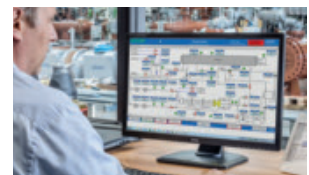

Contact

Would you like further information about these or other applications?
Do you require technical advice for your application?
application@krohne.com

Please visit our website for a current list of all KROHNE contacts and addresses.





APPLICATION NOTE

Monitoring energy consumption at an oil and gas field

- Equipping more than 70 bypass lines with gas flow measuring devices
- Vortex flow measurement of natural gas with integrated pressure and temperature compensation
- Detecting technical losses due to soot formation in burners

1. Background

A multinational oil and gas company explores and refines raw oil and natural gas in Northern Serbia. The oil and gas field stations have only recently been refurbished to meet the most complex production processes. All facilities comprise of a wide range of energy consuming devices such as heavy fuel and gas boilers, steam heaters, glycol dehydrators and compressors. Most of the systems are fueled with natural gas from the gas fields.

2. Measurement requirements

In order to control the energy efficiency of each of their gas field stations, the company decided to monitor the natural gas consumption of their systems as well as to detect technical losses due to soot formation in burners. The customer was therefore searching for a cost-effective gas flow measuring technology to be mounted in more than 70 bypass lines. Given the volatile parameters of the medium, it was a requirement that temperature and pressure measurement (4...60 barg / 58...870 psig) be part of the solution. ATEX zone 1 Ex ia approvals were also mandatory.



Vortex flowmeter mounted in a bypass line

3. KROHNE solution

The KROHNE representative, WIG DOO BEOGRAD, recommended using the Vortex flowmeter OPTISWIRL 4070 C, thereby prevailing over competitor solutions using turbine meters, rotary gas meters or multivariable transmitters. The operator installed more than 70 Vortex flowmeters from KROHNE at the gas field stations. The instruments were mounted in bypass lines to allow easy dismantling without process interruption. The majority of these lines were meant to be part of a permanent system of piping with different nominal sizes from DN 15 / 1/2" to DN 100 / 4" (classes: 150 lb, 300 lb and 600 lb). At these measuring sites flowmeters with sandwich process connections were used. Five other flowmeters were fitted at mobile metering systems that allow for temporary flow measurement at 14 varying measuring sites. These flowmeters were installed with flanges and all devices have corresponding ATEX approvals (Ex II 2G EEx d ia [ia] IIC T6).



Mobile metering system with a flanged OPTISWIRL 4070 C

The vortex flowmeter measures the operating volume flow of natural gas as well as calculates an accumulated standard volume flow of as low as 4 Sm³/h). As all devices also feature integrated temperature and pressure sensors, they can compensate for the unsteady parameters of the medium. Their readings are provided via 4...20 mA HART to a control room, from where they are telemetrically transferred to a SCADA system.

4. Customer benefits

The operator of the oil and gas fields now benefits from reliable energy monitoring that enables them to get an accurate overall measurement of their own consumption. The OPTISWIRL is a cost effective alternative to mechanical gas flow meters as it is maintenance-free and features integrated temperature and pressure compensation. It therefore requires no additional instrumentation to compensate for the unsteady parameters of the medium. This also makes the flowmeter a suitable device to control the maintenance requirements of burners and to prevent technical losses. Every time the nozzles of the burners start sooting, the pressure raises which can be effectively detected by the OPTISWIRL. As a result, predictive maintenance can be carried out, preventing costly process interruptions.



Installation of flowmeter with sandwich connection

5. Product used

OPTISWIRL 4070 C

- Vortex flowmeter for measuring operating, standard volumetric and mass flow of conductive and non-conductive liquids, gases and vapours
- 2-wire device with integrated pressure and temperature compensation
- Non-wearing, fully welded stainless steel construction with high corrosion, pressure and temperature resistance
- Optimal process reliability thanks to Intelligent Signal Processing (ISP) – stable readings, free of external influences
- Maintenance-free measuring sensor design



Contact

Would you like further information about these or other applications?
Do you require technical advice for your application?
application@krohne.com

Please visit our website for a current list of all KROHNE contacts and addresses.



www.krohne.com

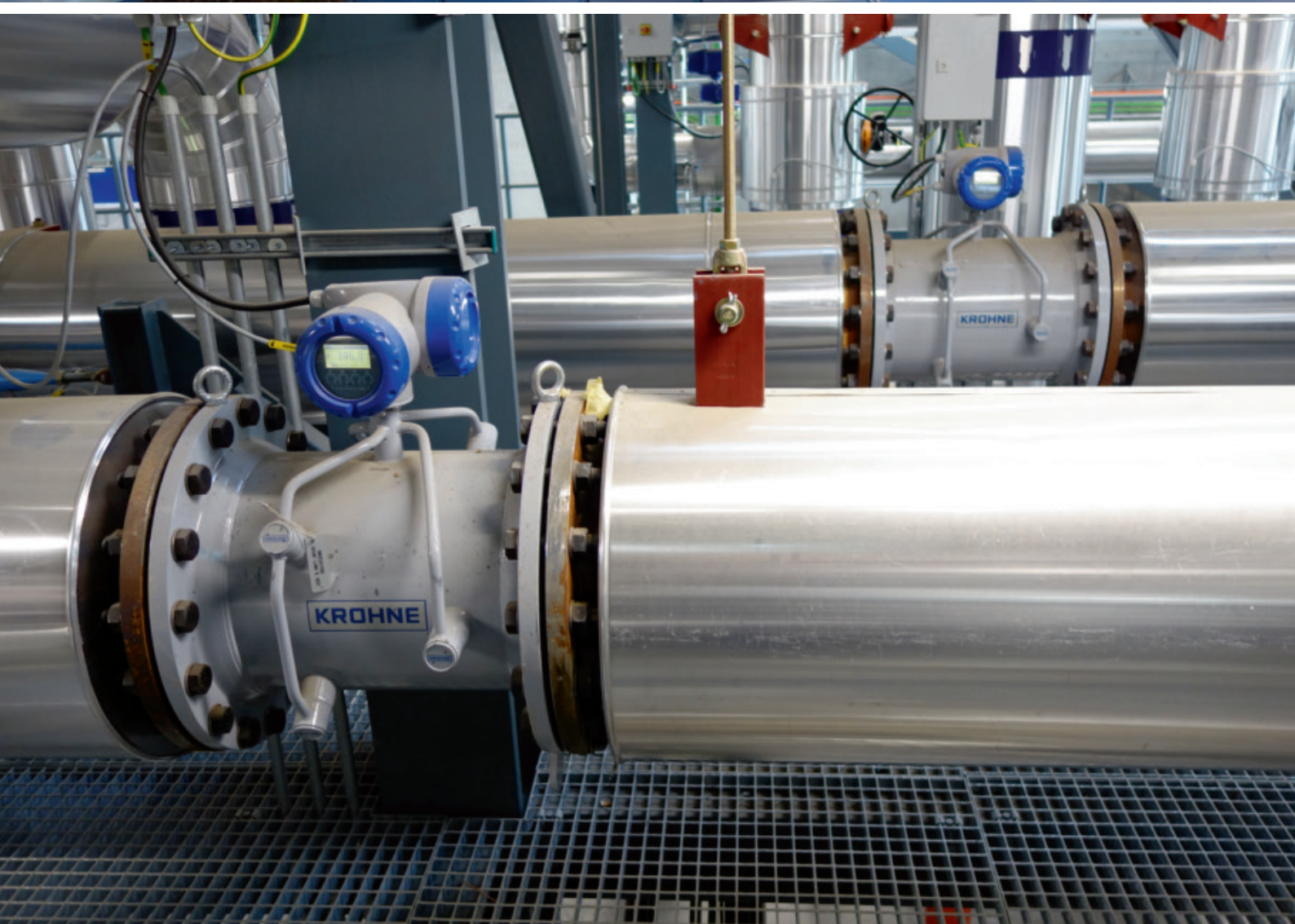

Chemical

- Determination of steam quantities from a gas-fired boiler plant 38
- Establishing energy efficiency 42
- Custody transfer flow measurement of hydrogen 44
- Differential pressure measurement
for an ultra-high-pressure application in an oxo plant 46
- On-site verification of process flows at catalyst plants 48



APPLICATION REPORT

Determination of steam quantities from a gas-fired boiler plant

- Accurate and reliable measuring data for the distribution and calculation of thermal energy
- Calibrated DP flow solutions for flow measurement of HP/LP steam and condensate (acc. to ISO 5167)
- Complete scope of delivery with flow nozzles, orifice meter runs, DP and pressure transmitters, temperature assemblies and flow computers
- Everything supplied from one source: from consultation and engineering to manufacturing and integration

1. Background

In 2017, international energy supplier E.ON entered into a long-term partnership with Dow Benelux to build, own and operate a large gas-fired boiler plant for their largest production site in Europe, located in Terneuzen, the Netherlands. At the site, Dow is producing chemical intermediates which are further processed for a variety of products in commercial and industrial business such as packaging, coatings and foams.

A new boiler plant was integrated by E.ON Power Plants Belgium into the existing steam distribution grid at the Dow Benelux site in Terneuzen. The boiler has dual-fuel capabilities and can be operated on all mixtures of natural gas, hydrogen of up to 45% and the by-product fuel gas of the naphtha crackers. The boiler plant and the necessary components were designed for extreme requirements of load gradients, steam pressure tolerance and availability.

2. Measurement requirements

In order to be able to distribute and determine the produced steam quantities as well as to measure the return flow of polished condensate, the plant had to be equipped with suitable measuring technology. This must be capable to measure with high accuracy over a large dynamic measuring range. For heat and mass balancing, the energy supplier required the measurement technology to be highly accurate in service, long-term stable and in accordance with the ISO 5167 standard. This implied that all meter runs need to be traceably calibrated at high Reynolds numbers.

Medium	HP steam	LP steam	Polished condensate
Volume flow rate	400 t/h	50 t/h	400 t/h
Design pressure	56 bar / 812.2 psi	10 bar / 145 psi	14 bar / 203 psi
Design temperature	+395°C / +743°F	+300°C / +572°F	+100°C / +212°F

3. KROHNE solution

Having considered different approaches to steam measurement, the plant operator decided in favour of KROHNE's differential pressure (DP) solution with an ISA 1932 nozzle as it was the most efficient choice when it comes to accuracy and long-term stability. The DP flow measurement with nozzle was engineered in accordance with ISO 5167 and ASME MFC-3M standards as per customer requirement.

The KROHNE scope of delivery for high-pressure (HP) steam, low-pressure (LP) steam and polished condensate measurement included six calibrated ISA 1932 nozzles (3 for HP steam, 3 for LP steam) and three calibrated OPTIBAR MR 4300 orifice meter runs (for condensate). The primary flow elements were installed in combination with the OPTIBAR DP 7060 differential pressure transmitter (incl. 5-way manifolds), the OPTITEMP TRA-S34 temperature assembly (incl. OPTITEMP TT 33 R rail-mounted temperature transmitter), plus the OPTIBAR PM 5060 pressure transmitter (with 3-way manifolds). As energy management in this project requires dedicated flow computing to determine the quantity and financial value of the HP/LP steam export as well as the import of polished condensate, KROHNE also provided a flow computer that calculates the energy of steam and condensate from the input variables flow rate, (differential) pressure and temperature.



Control cabinet with KROHNE DP and pressure transmitters, temperature transmitter and flow computer

4. Customer benefits

Using KROHNE's integrated DP flow solutions, the operator benefits from reliable and accurate data for heat and mass balancing. Given that even a small error can amount to a large financial difference in those projects, the calibrated DP flow solutions turned out to offer the best OPEX for the operator as they are long-term stable and accurate over a wide dynamic range. Designed in accordance with ISO 5167, the measured values of the DP flowmeters can be checked for plausibility during process operation, thus ensuring that the measuring devices still work accurately and reliably as per customer specification. KROHNE as a main instrument vendor (MIV) for this solution provided the whole scope of delivery - from consulting, engineering, manufacturing and testing to project management and integration of the measuring equipment into the operator's process control system.

5. Products used

ISA 1932 nozzle

- Flow nozzle for DP flow measurement of steam in acc. with ISO 5167, ASME MFC-3M or ASME PTC 6



OPTIBAR MR 4300

- Completely pre-assembled orifice meter run assembly



OPTIBAR DP 7060

- High performance DP transmitter with integrated line pressure measurement



OPTIBAR PM 5060

- Process pressure transmitter with metallic diaphragm



OPTITEMP TRA-S34

- Threaded RTD temperature assembly for use in existing thermowells



OPTITEMP TT 33 R

- Rail-mounted temperature transmitter with universal inputs and galvanic isolation



Contact

Would you like further information about these or other applications?
Do you require technical advice for your application?
application@krohne.com

Please visit our website for a current list of all KROHNE contacts and addresses.





APPLICATION REPORT

Establishing energy efficiency

- Accurate flow measurement of superheated steam
- Reduction in energy consumption
- Long-term stable and reliable measurement due to integrated meter verification



1. Background

The Pont-de-Claix (Isère) chemical plant used to be operated by Rhône-Poulenc but the activities were then divided and sold to different companies in the chemical sector. Today, Solvay is the provider of utilities including electricity, compressed air and superheated steam. The company operates 3 gas turbines with cogeneration. The energy sources are natural gas and hydrogen, a by-product of production. The distribution of these utility fluids supplies each operator in the Pont-de-Claix plant.



Start of the utilities towards the chemical plant

2. Measurement requirements

The customer would like to measure superheated steam at a temperature of 275°C, a pressure of 31 barg and a flow rate of 60 T/h. This will serve to establish energy efficiency in the cogeneration facilities. The customer had previously been using a competitor's vortex flowmeter. Customers of the chemical plant were consuming 900,000 tonnes of steam per year. Since making the new investments, this consumption has been reduced to 350,000 tonnes per year as a result of new, more energy efficient process units being constructed to replace the old ones.

This leads to many requirements for the measuring point:

- it must be able to cover a much larger flow range, particularly at low flows;
- it must measure in both directions because in the event of a stoppage of the steam production facilities, an external source for help must use the same pipelines but in the opposite direction;
- the generated pressure loss must be as low as possible to avoid wasting energy.

KROHNE

3. KROHNE solution

KROHNE supplied an OPTISONIC 8300 ultrasonic flowmeter with a 10" diameter and a 10" ASA 300 lbs connection.

The device was installed at the production outlet towards the units on a horizontal pipeline made of carbon steel. The required straight inlet/outlet runs were observed to ensure optimal accuracy. The customer insulated the entire installation.

Featuring an integrated mass flow calculation and a direct input for pressure and temperature measurement, the OPTISONIC 8300 is able to provide measurements in t/h (mass flow).



OPTISONIC 8300 ultrasonic flowmeter

Start-up was planned in conjunction with KROHNE customer service. For production reasons, steam supply started one week early, the device was operational immediately.

4. Customer benefits

The OPTISONIC 8300 flowmeter meets the customer's requirements, namely a large span, bidirectional measurement and no pressure loss. No regular maintenance is required and the self-diagnostics of the meter guarantees smooth continuous functioning of the device.

The OPTISONIC 8300 has become the reference meter for all the other measurements done by vortex flowmeters and orifice plates.

Solvay has reduced its energy consumption linked to the pressure loss of the previous measuring devices, the possible measuring zone has been extended, measuring accuracy has been improved and process safety has been enhanced thanks to the self-diagnostics. KROHNE Customer Service must perform an annual equipment verification with a verification tool in order to submit a report to the service quality department.

5. Product used

OPTISONIC 8300

- Ultrasonic flowmeter for high temperature gas and steam
- Accurate measurement without pressure loss
- No recalibration, no maintenance



Contact

Would you like further information about these or other applications?
Do you require technical advice for your application?
application@krohne.com

Please visit our website for a current list of all KROHNE contacts and addresses.



www.krohne.com



APPLICATION NOTE

Custody transfer flow measurement of hydrogen

- Reliable and highly accurate measuring system
- Comprehensive solution in accordance with MID MI-002
- Self-monitoring of the measuring system for process optimisation

1. Background

The Berre Petrochemical Cluster is a complex covering almost 1000 hectares located 30 km / 18.6 miles from Marseille, France, on the Étang de Berre lagoon. The site consists of a steam cracker as well as large-scale polypropylene and polyethylene plants. The polyolefin plants produce polypropylene and polyethylene, the majority of which is used for consumer and industrial applications. Also located on the site are chemical plants and logistics facilities such as port facilities, pipelines, storage terminals and transshipment facilities.

2. Measurement requirements

One of the producers requires the continuous flow measurement of hydrogen. The customer was looking for custody transfer flow measurement that would be in line with the internal procedure followed in compliance with the Sarbanes-Oxley Act (SOX). The main objective of the act is to oblige the companies in question to develop and implement their own control procedures used to detect cases of fraud and/or errors in the financial management of the company. This ensures that the financial data disclosed by the company is both accurate and applicable, preventing false reports from influencing prices on the stock market.

It is important for the customer to accurately determine and invoice the hydrogen flow. The volume flow varies from 100...400 kg/h / 3.67...14.7 lb/min, the pressure from 9...15.7 bar / 130.5...227.6 psi and the temperature from 0...+20°C / +32...+68°F. The producer required a pressure and temperature-compensated flow measurement (standard volume flow measurement) in custody transfer as per MID MI-002 and in accordance with the internal SOX procedure. To this end, the customer was looking for a reliable and accurate comprehensive system that would comply with both the MID requirements and the company's own procedures (accuracy, control, approval, documentation, certifications etc.). These measurements allow the customer to invoice hydrogen consumption and guarantee income. Previously, the company had used an orifice plate (not MID-compliant). The MID MI-002 approved equipment must also comply with ATEX Ex d.

KROHNE

3. KROHNE solution

KROHNE provided a measuring system complete with the ALTOSONIC V12 ultrasonic gas flowmeter (DN100, ASME Cl 300 flange) and the SUMMIT 8800 flow computer.

The ultrasonic flowmeter was installed in a horizontal stainless steel pipe with straight inlet and outlet runs. The measuring system complies with MID MI-002.

In addition, KROHNE offered the "KROHNE Care" expert system, providing diagnostic functions for the ALTOSONIC V12 ultrasonic gas flowmeter. Based on diagnostic parameters, this system interprets the functionality and accuracy of the measuring device around the clock.

The 12-beam measuring device features a vertical diagnostic path that detects contamination on the bottom of the measuring tube. KROHNE also offered to commission the system and train personnel in the use of the two measuring devices. The system had to feature integrated pressure and temperature sensors for custody transfer measurements. KROHNE prepared the documents for custody transfer including calibration certificates, MID certificates, technical documentation etc.



Custody transfer flow measurement with the ALTOSONIC V12 ultrasonic gas flowmeter

4. Customer benefits

The reliable and accurate measurement in accordance with MID is a clear benefit for the customer. The customer can now create invoices covered by MID approval that also comply with the internal SOX procedure.

Thanks to the "KROHNE Care" diagnostic system and the diagnostic path to detect contamination, this reliable and accurate measuring system featuring self-monitoring made process optimisation possible. As a result, production increased and the producer recorded increased revenue.



ALTOSONIC V12 diagnostic analysis

5. Products used

ALTOSONIC V12

- Ultrasonic flowmeter for custody transfer (CT) measurement of gases
- 12-beam device for high measuring accuracy
- OIML R137 (class 0.5), MI-002, AGA9, ISO 17089 etc.

SUMMIT 8800

- Flow computer for custody transfer measurement
- For the flow measurement of all liquid hydrocarbons, gas and steam
- Complies with all major international standards including OIML, ISO, API, AGA, GOST



CONTACT

Would you like further information about these or other applications?
Do you require technical advice for your application?
application@krohne.com

Please visit our website for a current list of all KROHNE contacts and addresses.





APPLICATION NOTE

Differential pressure measurement for an ultra-high-pressure application in an oxo plant

- Upgraded high-pressure orifice measurement for aldehyde production
- Retrofitting the entire measurement setup enhanced plant safety and availability
- Hydrogen-ready PN700 (~10000 psi) measuring cell in weight- and space-saving design

1. Background

At one of its European sites, a global chemical company operates a plant for the large-scale production of aldehydes and alcohols via oxosynthesis as well as acetic acid esters (acetates). The production facilities are set up to operate almost continuously.

2. Measurement requirements

The oxo-products are derived through specific reaction types. In the production of aldehydes, special olefins are reacted with oxo gas which is a mixture of carbon monoxide and hydrogen gases. Depending on the desired outcome, at pressures ranging from 15...700 bar (218 to 10,153 psi) and at temperatures of +80...100°C (+176...212°F) those olefin catalysts are introduced to convert the gas mixture into aldehydes. A gas flow of approx. 7 kg/h (15.4 lb/h) is continuously discharged from the process in a controlled manner. This raw product is then purified by distillation at standard pressure or vacuum.



Previous DP transmitter before replacement

To achieve the best possible conditions for the various olefins, this plant features different types of processes. The chemical company can operate the plant at up to 700 bars (~10000 psi) for testing and research purposes. To monitor the gas extraction, the operator uses a flanged orifice plate with pressure rating PN700. The measurement takes place at a differential pressure of 0...500 mbar (~7.3 psi) and is monitored from a control room.

The previously used transmitter and orifice meter assembly with associated impulse lines and shut-off equipment had to be replaced due to measurement errors. Since the plant has a dedicated measurement and control department, the customer has a great deal of experience in manufacturing orifice plate meter assemblies for high-pressure applications, thus they opted to produce the retrofit assembly in-house. However, finding a suitable hydrogen-ready differential pressure replacement transmitter for high static pressures proved difficult.

KROHNE

3. KROHNE solution

KROHNE was able to supply the OPTIBAR DP 7060 differential pressure transmitter with the necessary PN700 pressure rating and gold-coated diaphragms for this hydrogen application. It was rigorously tested at the customer's test center.

Given its pressure rating, the design of the OPTIBAR DP 7060 is unusually slim for a DP transmitter. Considering its pressure rating, when compared to other dP transmitters, the design of the OPTIBAR DP 7060 is unusually slim so its low weight and reduced size initially led to an increased need for more information for the customer's technical evaluation. The full test reports and complete device documentation supplied by KROHNE were able to quickly address all open questions relating to the unit's very slim design.

Once successfully tested, the pressure transmitter was qualified and approved for continuous differential pressure flow measurement with a design pressure of 700 bar at the Oxo plant. The device was subsequently installed and commissioned in the plant and the customer's technical staff adapted the pressure tapping, including the impulse lines, all on their own.



Retrofitted flange pressure tapping



OPTIBAR DP 7060 DP transmitter with space-saving design and PN700 pressure rating

4. Customer benefits

The onsite technical department responsible for the oxo plant is very satisfied with the KROHNE DP transmitter. The new measuring device ensures and substantially improves plant safety and uptime.

To further increase long-term stability and process reliability, the OPTIBAR DP 7060 was also 3D-linearised over the entire static pressure and ambient temperature operating range. Since all specified operating ranges are covered, a stable and accurate measurement can be guaranteed under all process conditions. As a rule, high line pressures and increased ambient temperatures have thus practically no influence on the measurement uncertainty.

KROHNE is now a well-accepted supplier of DP transmitters for differential pressure flow measurement in the Oxo production facilities. Many flow, level and process pressure measurements in the chemical industry are still done with pressure and differential pressure transmitters and KROHNE provides the full scope of state-of-the-art process measurement instrumentation. The OPTIBAR process pressure transmitters are SIL 2/3 certified with explosion protection and feature many communication protocols such as HART®7, FOUNDATION™ Fieldbus or Profibus-DP.

5. Product used

OPTIBAR DP 7060

- High performance DP transmitter with integrated line pressure measurement
- Unique 3D linearisation for excellent measurement stability over the entire static pressure and temperature range
- Ex ia, Ex d approvals; SIL 2/3 certified
- 2-wire, 4...20 mA/HART®, FF, Profibus-PA, Bluetooth®



Contact

Would you like further information about these or other applications?
Do you require technical advice for your application?
application@krohne.com

Please visit our website for a current list of all KROHNE contacts and addresses.



www.krohne.com



APPLICATION REPORT

On-site verification of process flows at catalyst plants

- Analysing errors in flow measurement processes
- Checking unexpected readings of inline flowmeters
- Avoiding process interruption and expensive opening of pipes



1. Background

Albemarle, a leading specialty chemical company, develops and produces catalysts for the petrochemical industry at its site in Amsterdam, the Netherlands. The facility comprises three different plants for fluid cracking catalysts (FFC), hydro processing catalysts as well as for isomerization, methyl chloride, methylamine, melamine and oxychlorination catalysts. These catalysts are used for the production of high quality fuels such as gas, petrol, diesel and kerosene from crude oil.

2. Measurement requirements

In order to control the flow process of the large variety of liquids, Albemarle uses over 500 inline meters, most of them electromagnetic flowmeters (EMF). Occasionally one of these meters measures an unexpected flow, showing a big deviation in flow rate or even no flow at all. In the past, Albemarle removed those inline flowmeters from the process in order to test their performance and functionality at the onsite repair department. However, as most of the removed inline flowmeters turn out to be fully functional, most of the errors indeed occur at another point in the process chain. Thus, opening the pipes causes an unnecessary and expensive interruption of the process. The customer was therefore looking for an on-site verification instrument to check the flow reading of the inline meters before dismounting.



3. KROHNE solution

KROHNE recommended the Ultrasonic clamp-on flowmeter OPTISONIC 6400. The portable ultrasonic device is battery powered and can be fitted on the outside of piping to measure the flow rate of liquids. As most of the pipes at the production site of Albemarle have only a diameter of DN 40 / 1 ½" and DN 50 / 2", the KROHNE device was delivered with small sensors which meet the requirements of the whole application.

The compact evaluation unit measures the flow velocity, the current volume flow and a variety of diagnostic values. The readings are shown on the large colour LCD in a graphical format. The OPTISONIC 6400 stores the readings in the integrated memory for data logging. They can also be transferred via USB stick to a PC for further analysis.



The OPTISONIC 6400 with mobile signal converter attached to a pipeline

4. Customer benefits

The portable clamp-on flowmeter is the suitable diagnostic device for Albemarle to speed up repair and save a lot of effort with all costs involved. Before opening any pipe or removing an inline meter, the chemical company can easily check the process flow whenever a vast deviation of the flow rate is indicated by an EMF.

The OPTISONIC 6400 offers a great deal of other advantages to the customer. Albermarle also benefits from the clamp-on flowmeter whenever one of the inline meters is broken and has to be temporarily replaced. The device can be installed within minutes and easily substitute the EMF, thus limiting downtime and avoiding a long term interruption of the process during repair time.

The clamp-on device also proved to be very useful during the extension of the customer's production site. Before a new production process is launched, the engineers of Albermarle test the process with water in order to detect possible leakage. During this test procedure the OPTISONIC 6400 is used to check the water flow and to diagnose whether the installed pumps really achieve the expected capacity, thus also extending the customer's knowledge of the process even before production is started.

5. Product used

OPTISONIC 6400

- Portable, battery powered ultrasonic Clamp-on flowmeter for liquids
- Suitable for a broad range of process conditions
- No process shutdown required for diagnostic on meters
- Quick start-up and ease of installation (installation wizard)
- For tube diameters from DN 15 (1/2") to DN 4000 (160")



Contact

Would you like further information about these or other applications?

Do you require technical advice for your application?

application@krohne.com

Please visit our website for a current list of all KROHNE contacts and addresses.



www.krohne.com



Steel & Metal

- High temperature flow measurement of CO₂ and H₂ from a reactor column 52
- Hydrogen flow measurement in tungsten production 56



APPLICATION REPORT

High temperature flow measurement of CO₂ and H₂ from a reactor column

- Improving sustainability and decreasing the carbon footprint of steel production
- Ultrasonic flow measurement to monitor H₂ and CO₂ separation from flue gases
- Real-time measurement of various gas mixtures at high temperatures

TNO innovation
for life

1. Background

TNO is an independent Dutch research organisation focussed on developing knowledge and innovations for practical applications. Together with their partners, TNO initiated the STEPWISE project to demonstrate the cost-effective carbon dioxide (CO₂) capture from residual gases in the steel industry and to create value from the energy content of the flue gases. The technology demonstrated in this project helps the steel industry reduce their CO₂ footprint and improve sustainability. The project is supported by the European Horizon 2020 Low Carbon Energy programme.

One type of flue gas in steel production is blast furnace gas (BFG). It is a by-product of the iron ore reduction process in blast furnaces and it is commonly used as a fuel in steel works or is used in boilers and power plants. The heating value of the BFG is quite low as it mainly consists of nitrogen (55%), carbon monoxide (25%), carbon dioxide (20%) and hydrogen (2...4%).

In Luleå, Sweden, STEPWISE demonstrates in a steel plant how to achieve the removal of 14 t/day of CO₂ from the blast furnace gases and to make a hydrogen-rich stream available. The captured CO₂ can be transported and stored (CCS) or can be used as feedstock for the production of synthetic methanol, which can serve as a fuel in the steel plant. The hydrogen-rich stream can be used as fuel for power plants or as feedstock for the production of ammonia.

2. Measurement requirements

In the STEPWISE demonstrator project, the innovative Sorption Enhanced Water Gas Shift (SEWGS) process is applied. The process is fed with a flue gas mixture from the steel plant. In a first step carbon monoxide (CO) is converted into CO₂ and hydrogen (H₂) by reacting with steam via the water-gas-shift (WGS) reaction. For BFG this results in a reduction of the CO content from 25% to 5%.

In a subsequent step the gas mixture enters the SEWGS reactor where the remaining CO is converted to CO₂ and H₂. In this process step a solid adsorbent is used which binds the produced CO₂ and as a result a hydrogen-rich stream leaves the reactor.

The SEWGS process operates at increased temperature and pressure, up to +540 °C / +1004 °F and 50 bar / 725 psi. The moment the sorbent is saturated with adsorbed CO₂, regeneration is performed via a combination of pressure release and steam purge. In this way, a CO₂-rich stream is obtained by condensing out the steam. The SEWGS process results in a separate H₂-rich stream and a separate CO₂-rich stream, leaving the reaction column it two different pipelines.

To assess whether the gases have always been successfully separated and to know how much CO₂, H₂ (plus nitrogen) and steam leave the column, TNO needed suitable flow instrumentation. It was required that the flowmeter provides real-time measurement of high temperature gases up to + 540°C / +1004°F, while offering a high degree of flexibility to deal with fluctuating gas compositions and different gas mixtures. Given that the CO₂ gas leaves the column at very low pressures, pressure loss was not an option.

3. KROHNE solution

The OPTISONIC 8300 ultrasonic flowmeter turned out to be the perfect fit for this challenging application. Designed for flow measurement of high temperature gas mixtures and a track record in steam applications, the gas flowmeter fully met all technical specifications and was welded into the CO₂ line (DN100) and the H₂ line (DN125). Any changes in terms of installation design were not necessary.

Utilizing the ultrasonic differential transit-time principle, the OPTISONIC 8300 is able to measure different gas mixtures independently from the gas composition. It allows for real-time flow measurement, which is particularly crucial when it comes to detecting transition phases of the gas mixture ratio. This enables the operator to measure all gas batches without any loss of measurement values. The outgoing volumetric flows are recorded by an analyser and linked to the time at which the flowmeters pass on the readings to the PLC.

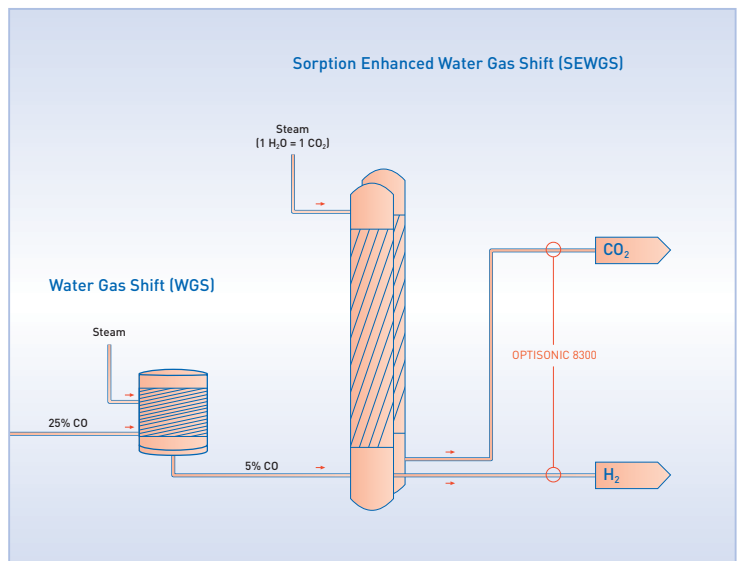

Schematic of STEPWISE process with the OPTISONIC 8300

4. Customer benefits

Helping the customer assess how efficient their separation process is, the KROHNE gas flowmeter plays an important role in optimising the SEWGS process. The OPTISONIC 8300 enabled TNO to continuously measure the outgoing flows even with the gas composition changing during the time of a batch. This was particularly crucial to the operator as the process can be optimized this way without installing additional flow instrumentation, which can be a tremendous cost factor. Due to the real-time measurement of the KROHNE flowmeter, no measuring values are lost, even during transition phases.

In terms of pressure loss, the customer benefitted from the full-bore design of the OPTISONIC 8300. The flowmeter has no moving parts or obstructions and causes virtually no pressure loss, which saves on pump capacities and energy costs. Another major advantage for TNO is the maintenance-free design of the ultrasonic flowmeter. It is not subject to wear or contamination. Given that TNO's processes need to be stopped occasionally, deposits can precipitate. Accuracy and signal strength, however, are not affected by deposits, so recalibration of the flowmeter is not necessary and allowed it to be directly welded into the pipes.

The OPTISONIC 8300 once again proved to be a reliable high-performance meter for CO₂ and H₂, which makes it a solid option in follow-up projects. The KROHNE flowmeter even enables the customer to determine the gas composition of two mixed gases based on the velocity of sound. Though currently not an issue for TNO, real-time analysis of the gases that pass through the pipes would be possible just yet without additional flowmeter installation, making the OPTISONIC 8300 not just a flowmeter, but a compact device for the real-time analysis of gas compositions.



Ultrasonic flow measurement of a high temperature hydrogen/steam mixture

5. Products used

OPTISONIC 8300

- Ultrasonic flowmeter for superheated steam and high temperature gases
- 2-path meter with optional mass flow and enthalpy calculation
- Integrated flow computer option, current inputs for external pressure and temperature sensors
- Bi-directional flow measurement over a wide dynamic range
- Full bore design: No moving parts, no wear, no pressure loss
- Extensive online diagnostics and functions for proper meter operation and verification
- Up to +620°C / +1148°F; Higher temperature and pressure ranges on request
- Ex zone 0 approval up to +600°C / +1112°F
- DN100...1000 / 4...40"; max. PN250 / ASME Cl 2500



Contact

Would you like further information about these or other applications?
Do you require technical advice for your application?
application@krohne.com

Please visit our website for a current list of all KROHNE contacts and addresses.





APPLICATION REPORT

Hydrogen flow measurement in tungsten production

- Ensuring consistent hydrogen flow rates for the reduction of hot tungsten oxide to tungsten powder
- Reliable variable area flow measurement at only 40 mbarg / 0.58 psig
- Local and direct reading of hydrogen flow into a reactor furnace without auxiliary power



1. Background

New York (USA) based Buffalo Tungsten Inc. is a leading independent manufacturer of tungsten metal powders made from raw materials like tungsten oxide (WO₃). These powders are sold to powder metallurgy companies and other manufacturers of tungsten finished products.

2. Measurement requirements

Tungsten powder production involves an industrial process in which tungsten oxide is reduced in a hydrogen furnace at 800°C / 1472°F. In the last production step the hot tungsten oxide reacts with hydrogen to tungsten and water (WO₃ + 3 H₂ = W + 3 H₂O).

The reducing atmosphere can only be maintained with constant hydrogen flow rates. Therefore the customer required continuous flow measurement of the hydrogen volume flow to the reactor furnace. The line pressure in this application was as low as 40 mbarg / 0.58 psig.

Application Data	
Medium	Hydrogen (H ₂)
Measuring range	6 ... 60 Nm ³ /h
Pressure	0.04 barg / 0.58 psig
Density	0.0899 kg/Nm ³
Temperature	20°C / 68°F



3. KROHNE solution

The tungsten producer opted for the VA 40 variable area flowmeter since it is particularly suitable for low pressure gas applications. A total of 14 flowmeters have been installed in the hydrogen supply lines of the furnace, using flanged process connections.

Since a local flow indication of hydrogen was sufficient, the devices were provided as purely mechanical flowmeters. The measuring cone of the VA 40 features a viewing glass protected by a metal sleeve that makes it easy to directly read the flow and to observe the medium. It works without need for power supply.



Hydrogen flow measurement with the VA 40 variable area flowmeter

4. Customer benefits

Buffalo Tungsten benefits from a very cost-effective device that allows an operator to quickly visually scan and check the float position in each meter. Constant hydrogen flow rates can thus be easily monitored just by walking by the hydrogen feed lines.

Given the extremely low pressure conditions, the VA 40 is the most suitable flowmeter that even outweighs the benefits associated with more advanced and expensive flowmeter types in this application.

Should the customer decide to further automate the hydrogen monitoring, the VA 40 can also be provided with an analogue output (4...20 mA) or MIN/MAX switches to trigger an alarm, if a certain threshold is exceeded or if the flow rate falls below a defined limit.

5. Product used

VA 40

- Variable area flowmeter for applications with liquids and gases
- Simple, low-cost measuring principle without auxiliary power
- With glass tube, optional MIN/MAX switches and 4...20 mA
- Low pressure loss for gas applications
- Flange: DN15...50 / 1/2...2"; also available with threads (NPT, G) and other connections
- -20...+100°C / -4...+212°F; max. 10 barg / 145 psig
- Various hazardous area approvals



Contact

Would you like further information about these or other applications?

Do you require technical advice for your application?

application@krohne.com

Please visit our website for a current list of all KROHNE contacts and addresses.



www.krohne.com



Food & Beverage

- Multiparameter biogas measurement 60
- Monitoring and control of CIP return lines in a dairy 62
- Flow measurement of liquid nitrogen for tunnel freezers 64
- Energy management for a sustainable beer production 66



APPLICATION REPORT

Multiparameter biogas measurement

- Measurement of methane content, flow, pressure and temperature
- Increased accuracy, maintenance-free installation
- All-in-one measuring device provides full process control



1. Background

Häagen-Dazs is a luxury ice cream produced in France. The North American company General Mills owns the brand and manufactures ice cream and sorbet in Tilloy-lès-Mofflaines in the district of Arras in Northern France. The products contain natural ingredients with no artificial colours or flavours and very little air, providing them with a thick consistency.

2. Measurement requirements

The customer made the decision to invest in a new biogas plant to effectively utilise the production residue treated in its own wastewater treatment plant. This makes it possible to extract methane and use it as a source of energy in cogeneration.

The plant consists of two digestion towers. At the end of the production process, the biogas is treated and water and hydrogen sulphide (H₂S) are removed. The biogas is then used in cogeneration. The biogas powers 3 gas engines. The electricity produced is then sold to EDF. A heat exchanger uses the heat produced by the turbines to heat the fermenters.

Biogas composition	
Methane (CH ₄) content	70% (vol.)
Carbon dioxide (CO ₂) content	26% (vol.)
Oxygen content	4% (vol.)

The biogas must be measured because it is being used to generate heat and power. In order for the process to be as controlled as possible, the flow, pressure and methane content of the medium must be as stable as possible. For this reason, the customer needed to measure the flow of biogas with different gas compositions at the outlet of two digestion towers in two separate pipes. The flowmeters also needed to compensate for changing operating conditions via integrated temperature measurement.



3. KROHNE solution

The methane content in the biogas can be calculated using the sound velocity and temperature. This makes it possible to monitor the performance of the biogas plant. The OPTISONIC 7300 Biogas ultrasonic flowmeter determines the flow of biogas using the differential transit time method. The measuring device also measures the sound velocity at the same time. On this basis and taking into consideration the gas temperature, adiabatic index and the universal gas constant, the flowmeter also calculates the molar mass, which it can then use to determine the methane content with an accuracy of $\pm 1\%$ of the measured value. KROHNE recommended equipping the outlet pipes of both digestion towers with OPTISONIC 7300 Biogas ultrasonic flowmeters. One of the devices was installed in the hazardous area of the plant. This flowmeter features an integrated temperature sensor. It was connected to the OPTIBAR PM 5060 pressure transmitter at the measuring point to calculate the volume flow to standard conditions.



OPTISONIC 7300 Biogas ultrasonic flowmeter and OPTIBAR PM 5060 pressure transmitter installed at the outlet of the digestion tower

4. Customer benefits

The customer has the benefit of an all-in-one device that is capable of taking various measurements (current flow, methane content/ CH_4 , pressure, temperature and total flow). This information enables the company to manage its biogas process accordingly. Based on this multiparameter measurement, Häagen-Dazs decided on KROHNE. The integrated calculation of the methane content in the biogas makes it possible for the operator to accurately determine the energy production of the process. The flowmeter provides measuring results with an accuracy of $\pm 1\%$ of the measured value. The customer benefits from reliable measurements at variable operating pressure, regardless of gas composition. In addition, the device requires no maintenance and features outstanding long-term stability.



Measuring device start-up carried out by a KROHNE service technician

5. Products used

OPTISONIC 7300 Biogas

- Ultrasonic flowmeter for biogas
- Integrated standard volume correction and methane content measurement
- Integrated temperature measurement, integrated pressure sensor optional
- Insensitive to moisture and variable gas composition
- No pressure drop; offers high accuracy and long-term stability
- Also suitable for use in hazardous areas (ATEX Zone 1)



OPTIBAR PM 5060

- Pressure transmitter for pressure and level applications
- Rugged design with metallic diaphragm
- A variety of thread, flange and other connections



Contact

Would you like further information about these or other applications?
Do you require technical advice for your application?
application@krohne.com

Please visit our website for a current list of all KROHNE contacts and addresses.





APPLICATION NOTE

Monitoring and control of CIP return lines in a dairy

- Improved detection of transition phases to ensure multiple use of costly detergents
- Inductive conductivity measurement for the separation of water, caustic and acid solutions
- Significant reduction of operating and purchasing costs thanks to increased sensor lifetime

1. Background

One of the world's leading manufacturers of dairy products, plant-based nutrition and beverages operates a production facility for yogurt products in Brazil. To ensure safe and high quality products, the company globally follows stringent hygienic procedures. This involves thorough cleaning of all their closed systems such as pipes and vessels applying the Clean-in-Place (CIP) method.

2. Measurement requirements

The CIP cycle at the plant consists of several cleaning steps. At first, purified water is rinsed through the lines followed by a caustic solution as the main disinfectant. Subsequently, intermediate cleaning with purified water is carried out before the lines are flushed with an acid solution to remove all residuals.

Given the high costs for the cleaning agents, the food company runs a recirculation system to feed back all liquids to their corresponding tanks for reuse in the next CIP cycle. Reusing the detergents requires the liquids to be separated precisely. The whole system has a high degree of automation depending on the inductive conductivity as a control input to identify the transition phase between each liquid.

The customer had so far used an inductive conductivity sensor from a major supplier of process instrumentation. However, this sensor type frequently needed maintenance and replacement due to damages caused by mechanical stress and temperature shocks. The quality issues and the poor lifetime of this sensor prompted the company to search for an alternative solution for CIP return control.

3. KROHNE solution

The food company decided to trial the OPTISYS IND 8100. The inductive conductivity measuring system is particularly designed for transition phase monitoring to control CIP return. Its flexible design allows installation with a wide range of hygienic adapters in accordance with EU1935/2004 and FDA regulations. In this application, the PEEK sensor with EHEDG and 3A certified VARIVENT® adapter was used. The adapter has a surface roughness of Ra <0.8 for food applications.

The customer decided in favour of the remote version of the measuring system that allows the converter to be mounted up to 10 m / 32.8 ft away from the sensor. This enables comfortable on-site monitoring when needed. The stainless steel housing of the inductive conductivity measuring system is IP69K rated and thus suitable for high pressure water jet cleaning.

The KROHNE system enables the dairy operator to select up to 14 different measurement ranges. Prior to delivery, an 80 point linearization of the OPTISYS IND 8100 had been carried over the whole of the measurement ranges, which enables reliable and long-term stable conductivity measurement. As the inductive conductivity of each cleaning agent is temperature-dependent, the conductivity system also features a Pt100 temperature sensor (Class A) to compensate for the temperature impact on the measurement.

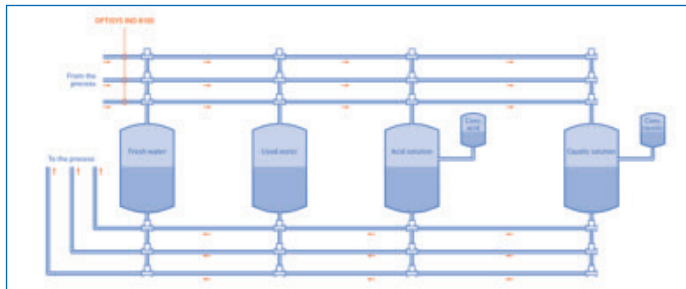

CIP cycle schematic with the OPTISYS IND 8100 inductive conductivity sensor



OPTISYS IND 8100 shortly after commissioning



Inductive conductivity measurement of cleaning agents

4. Customer benefits

While the competitor's system caused extensive maintenance and had to be replaced every six months, the tested OPTISYS IND 8100 provided long-term stable measurement without interruption for three years. The dairy was so satisfied with the KROHNE measuring system that they decided to replace the old system with the OPTISYS IND 8100, reducing operating and even purchasing costs.

Due to the much more accurate inductive conductivity measurement, the transition phase of the different cleaning agents is reliably detected. The CIP return lines are properly controlled. The liquids can thus be effectively separated and fed back to their corresponding tanks, ensuring multiple use of process water as well as caustic and acid solutions.

5. Product used

OPTISYS IND 8100

- Inductive conductivity measuring system for food and beverage applications
- 4-wire, 4...20 mA, with head-mounted or remote transmitter
- Hygienic PEEK sensor, robust (IP69K), with temperature compensation
- 14 selectable measuring ranges: 0.05...1000 mS/cm; fully calibrated



Contact

Would you like further information about these or other applications?
Do you require technical advice for your application?
application@krohne.com

Please visit our website for a current list of all KROHNE contacts and addresses.



www.krohne.com



APPLICATION REPORT

Flow measurement of liquid nitrogen for tunnel freezers

- Consumption measurement for freezing goat cheese
- Use of Coriolis mass flowmeters for continuous flow measurement at -170°C / -274°F
- Cost-effective cryogenic process for the best possible product yield



1. Background

EURIAL is France's second largest dairy cooperative. The group includes 24 dairies and cheese dairies with over 4600 employees. The milk processor specialises in the three business areas "conventional cow's milk", "organic cow's milk" and "goat's milk". The EURIAL Group sells its milk products to all major food retailers, wholesalers, restaurant chains and food manufacturers.

2. Measurement requirements

Before it is supplied to restaurants and food producers, goat cheese is fed into tunnel freezers after production. This cryogenic freezing allows the cheese to be preserved for a long time.

For cryogenic processing the company uses liquid nitrogen with a temperature of around -170°C / -274°F that is driven into a cooling system at a pressure of 1.4...2 bar / 20.3...29 psi. As the medium is cost-intensive the cryogenic process must be operated as efficiently as possible. It is therefore important for the customer to continuously determine the liquid nitrogen consumption in his two tunnel freezers.



Tunnel freezer for cryogenic freezing of goat cheese

In the past, the customer had the liquid nitrogen consumption checked only every two years by a service company. However, this sporadic bypass measurement was too inaccurate to identify efficiency loss. In order to permanently optimise the cryogenic process and save costs, the company decided to continuously determine the current and total nitrogen flow.



3. KROHNE solution

KROHNE recommended the OPTIMASS 6400 F for this cryogenic application. Due to its high-end options, the Coriolis mass flowmeter with twin bent tube is ideally designed for the flow measurement of cryogenic media such as liquid nitrogen.

The customer uses the OPTIMASS 6400 in the supply lines to both tunnel freezers. The flowmeters were supplied in size DN25 with measuring tubes made of stainless steel (1.4404 / 316L). In addition, both instruments were completely equipped with insulating housings ex works. In order to be able to carry out a zero point calibration of the measuring instruments on site, a valve was mounted behind each Coriolis meter.



Mass flow measurement of liquid nitrogen for tunnel freezers with the OPTIMASS 6400 F



4. Customer benefits

By continuously and accurately determining the current and total mass flow, the customer benefits from precise monitoring of liquid nitrogen consumption.

Using the OPTIMASS 6400 helps the dairy cooperative constantly optimise the cryogenic process to always supply both tunnel freezers with the same amount of nitrogen. This ensures cost-efficient freezing of goat cheese with the best possible product yield in mind.



Shock-frozen goat cheese leaving a tunnel freezer; above: OPTIMASS 6400 F

5. Product used

OPTIMASS 6400 F

- Coriolis mass flowmeter for cryogenic applications (down to -200°C / -328°F) in food and other industries
- Highly accurate measurement of mass flow, density and volume flow
- Flange: DN10...300 / 1/2...12", max. PN 160 / ASME Cl 1500
- Also available as hygienic version



Contact

Would you like further information about these or other applications?
Do you require technical advice for your application?
application@krohne.com

Please visit our website for a current list of all KROHNE contacts and addresses.





APPLICATION REPORT

Energy management for a sustainable beer production

- Flow measurement of steam, compressed air, CO₂ and water
- Detecting measurement deviations to avoid losses
- Managing energy to reduce consumption
- A tailored technical proposal



1. Background

Established in France since the 70s, Heineken chose a unique business model as both brewer and distributor.

Heineken has sold 5.7 million hectolitres of beer, including the brands Heineken, Desperados, Pelforth, Affligem and many others such as Fisher and Edelweiss. More than 4000 employees working all over France and the 1.66 billion euros in revenue generated in 2014 illustrate the success of the company's strategic positioning.

To maintain its market position and become the most sustainable brewery in the world, the company invested in the BABW programme (Brewing A Better World) in 2008. The goal is a 40% reduction in CO₂ emissions by 2020.



Vortex flowmeters measuring compressed air

2. Measurement requirements

The group faced the facts and started replacing old equipment such as water heaters and air compressors. In order to move on with the BABW approach and to make further progress, it was necessary to retrofit the process instrumentation used for operating their EMS (Energy Monitoring System). The company focused on 3 priorities: electricity, heating and water. The heating part involved the distribution of compressed air, cold and steam. There were some orifice plates and thermal mass flowmeters installed which, however, dated back to the 1980s and were completely obsolete.



3. KROHNE solution

Measurements are done on utility fluids: steam, compressed air, CO₂ and water. Having taken an inventory of the key points of measurement, specifications were established and sent to different suppliers on the market. After the analysis of the various technical proposals it was the KROHNE solution that was chosen. It came closest to meeting Heineken's needs in terms of standardising measurements so that they can be compared to one another, the dynamics of the broadest measuring ranges and considerable accuracy when detecting anomalies. The customer chose the OPTIFLUX 4300 W electromagnetic flowmeter for water networks, alcoholised water (the alcohol is an antifreeze that retains the food properties) and chilled water. The OPTISWIRL 4070 vortex flowmeter was selected for compressed air and steam and the OPTIMASS 6400 Coriolis mass flowmeter for measuring CO₂. A total of 28 KROHNE sensors were installed. Heineken recognised that KROHNE proposed the best technological solution at the best price.



Electromagnetic flowmeters on water circuits

4. Customer benefits

"Energy is everybody's business" states Heineken's project manager for energy and utilities. Today, these measures help manage investments, e.g. to implement regulations. All employees are to be involved in energy monitoring because it's the best way to reach objectives. When it comes to energy consumption, all relevant information is visualised on a dash board in the control room. The site consists of approximately 250 flowmeters and these new points of measurement generate alerts at the earliest sign of deviation in consumption, enabling immediate intervention to resolve the problem. The French sites have the same equipment and that applies to Eastern Europe as well. Heineken's internal procedure is 90% identical to the ISO 50001 standard and the company has decided to go for this certification.

5. Products used

OPTIFLUX 4300

- Electromagnetic flowmeter for highly accurate bi-directional flow measurement of liquids
- Wide measuring range DN2.5...3000 / 1/10...120"

OPTISWIRL 4070

- Vortex flowmeter for measurement of saturated steam, superheated steam, gases and wet gases with varying process conditions
- Available with integrated pressure/temperature compensation and flow calculation

OPTIMASS 6400

- Coriolis mass flowmeter for liquids and gases with V-shaped twin measuring tube
- Wide measuring range (DN 10...300 / ½...12")



Contact

Would you like further information about these or other applications?
Do you require technical advice for your application?
application@krohne.com

Please visit our website for a current list of all KROHNE contacts and addresses.



www.krohne.com



Water & Wastewater

- Flow measurement of wet biogas 70
- Gauge pressure measurement in the aerator line of an aeration basin 72
- Leak management system with GPRS remote monitoring
in the Rio de Janeiro drinking water network 74



APPLICATION REPORT

Flow measurement of wet biogas

- Biogas produced from sludge digestion for the energy neutral operation of a sewage treatment plant
- Ultrasonic flow measurement and control of biogas production
- Integrated methane content measurement of digester gas with a varying composition and high CO₂ content



1. Background

The Dutch Water Authority Rivierenland (WSRL) has expressed the ambition to operate completely energy neutral by 2030, with 40% of its own energy generated sustainably as an interim step by 2020. The energy factory in Tiel is fully in line with this goal. Having started operation of the sludge digestion plant, the wastewater treatment plant (WWTP) in Tiel is 100% energy neutral. The plant uses the residual sewage sludge to generate biogas, which is then used as a raw material for energy production.

2. Measurement requirements

WSRL produces biogas by digesting sewage sludge in a digester tank, which has been raised to +52°C / +125.6°F. The biogas is then used to meet the energy demand of the treatment plant. The biogas flow between the digester tank and the power plant must be accurately measured and monitored for the control and safety of the energy plant.

It is a challenge to measure the biogas that leaves the digester wet, pressureless and with varying methane and CO₂ content. A gas flowmeter especially developed for this application must therefore be used. WSRL also needs to monitor and record excess gas quantities that are flared off for the information of the inspection authorities.

3. KROHNE solution

KROHNE supplied the OPTISONIC 7300 Biogas, an ultrasonic gas flowmeter with integrated temperature measurement, specifically developed for biogas applications. With this meter WSRL can measure the corrected gas volume flow accurately in real time.

Due to the flowmeter design, the measurement is not influenced by moisture content, and therefore the OPTISONIC 7300 Biogas can be mounted directly behind the digester. This provides direct information of the gas amount leaving the digester. Independent of the gas composition, the ultrasonic measurement also makes it possible to measure varying gas composition without any pressure loss.

Moreover, WSRL is now able to use the measured velocity of sound of the medium to analyse the methane content of the gas.

4. Customer benefits

By opting for a flowmeter with integrated analytical capabilities as well as an integrated mass flow calculation independent of the installation environment, WSRL significantly reduces operating costs.

There is no need for a separate gas analyser as the OPTISONIC 7300 Biogas features integrated methane content measurement in real time based on the velocity of sound of the biogas. In this way, the operator is always provided with information on the gas composition and can take steps to maintain the efficiency of the CHP plant or maximize the biogas yield as necessary.



Flow measurement of biogas behind the digester

The customer benefits from a flowmeter that is insensitive to moisture, allowing the measurement to be carried out directly in the wet biogas stream, without having to dry it in the first place. It works independently of the gas composition and is therefore suitable for a varying biogas composition.

As compared to conventional mechanical flow instrumentation, WSRL benefits from an extended maintenance interval. As the device doesn't cause any pressure loss, the operator saves on pump capacity and thus energy costs in the long run.

5. Product used

OPTISONIC 7300 Biogas

- Ultrasonic flowmeter for biogas (dry or wet), landfill and sewage gas applications with a high CO₂ content
- Integrated gas volume correction and methane content measurement
- With integrated temperature sensor and optional pressure sensor
- Lap joint flange: DN50...200 / 2...8", max. PN10 / ASME Cl 150
- Large turndown ratio (100:1), no periodical maintenance needed
- Available as remote version with field converter
- Also for use in hazardous areas zone 1
- Full bore design: No moving parts, no wear, no pressure loss
- High accuracy: ±1% error of measured value



Contact

Would you like further information about these or other applications?

Do you require technical advice for your application?

application@krohne.com

Please visit our website for a current list of all KROHNE contacts and addresses.



www.krohne.com



APPLICATION NOTE

Gauge pressure measurement in the aerator line of an aeration basin

- Reliable detection of the contamination degree of aeration elements
- Determination of cleaning intervals based on overpressure threshold values
- Robust, drift-free pressure transmitter for monitoring oxygen supply and aerator performance
- Timely removal of deposits without maintenance-related basin drainage

1. Background

A municipal water association in eastern Germany is, among others, responsible for the treatment of wastewater and rainwater from surrounding municipalities. Via a separate system the wastewater loads are transferred to a centralised wastewater treatment plant (WWTP) with a biological treatment stage. To be able to biochemically convert the organic matter in the wastewater into biomass and carbon dioxide, the aeration basin must be supplied with oxygen. The aeration process accounts for around 70% of the wastewater treatment plant's total electricity consumption. In order to substantially increase operational safety and efficiency, the plant operator recently extensively modernised the aeration system and also replaced the aerators.

2. Measurement requirements

Next to parameters such as the air volume, the condition of the membrane aerators plays a vital role in injecting oxygen effectively. This is best achieved through fine-bubble distribution over a large area. The blower performance and thus the power consumption depends on the throughput and the back pressure. The condition of the pores in the aerator membranes has a significant impact on the back pressure and the uniformity of the fine bubbles. These pores become clogged with various deposits over time. This reduces the efficiency of the oxygen input while the energy demand increases.

Draining the aeration basins to clean the aeration elements is in most cases not possible or very costly. Depending on the contamination level, the operator therefore injects formic acid (methanoic acid) together with the air flow. In this way, acid soluble deposits can be effectively removed. In order to be able to determine the degree of contamination and to ensure a constantly high aeration performance as well as efficient and uninterrupted operation, the operator decided to use state-of-the-art process measurement instrumentation.

KROHNE

3. KROHNE solution

The customer uses the OPTIBAR PM 5060 pressure transmitter on the various aerator lines. The KROHNE device continuously monitors the degree of contamination of the various aerator lines by gauge pressure measurement. Depending on contamination trends and the stored limit values, the system operator runs a targeted cleaning cycle. For the injection of formic acid, the customer uses the pressure monitoring of the individual aerator lines in relation to a defined delivery rate and immersion depth. In addition to oxygen measurement, the overpressure also serves as an important parameter for controlling the blower output. The OPTIBAR PM 5060 transmits the measured values directly to the control room.

The process pressure transmitter is insensitive to pressure surges and pulsation and enables reliable, long-term stable measurement. It has a fully welded metallic diaphragm and thus offers a high level of protection against leakage. Since the weld seams of the diaphragm are drawn over the sealing surface, there is no contact of the process medium with the less corrosion-resistant weld seam and the material transition of the diaphragm to the base material. This makes the OPTIBAR PM 5060 well designed for the prevailing operating conditions of the sewage treatment plant, in particular the rotary lobe compressors and the corrosive process conditions.

The gauge pressure transmitter was supplied for this application with an electropolished stainless steel housing, which makes the measuring device robust against external influences that can sometimes be abrasive at the WWTP. Commissioning of the pressure transmitter is either possible via the keyboard on the modular display, via Bluetooth® using a mobile device with the KROHNE Pressure Mobile app or quickly and easily via HART®.



Gauge pressure measurement in an aerator line with the OPTIBAR PM 5060



Aeration elements of an aeration basin

4. Customer benefits

The OPTIBAR PM 5060 makes an important contribution to maintaining the high performance of the aeration system and accurately determining the right time for cleaning intervals. Continuous pressure monitoring enables the operator to detect contamination trends at an early stage. The customer can take immediate action to prevent efficiency losses and operate the aeration basins in the most energy-saving way possible and without process interruption. Defective aerator elements can be identified in time.

5. Product used

OPTIBAR PM 5060

- Pressure transmitter for process pressure and level applications
- Rugged design with fully welded metallic diaphragm suited to high pressure ranges and hygienic requirements
- 100 mbar...1000 bar
- Various housing materials available: plastic, aluminium, stainless steel
- 2-wire, 4...20 mA/HART®, FF, Profibus-PA, Bluetooth®



Contact

Do you have questions or are you interested in this or other applications?
 Would you like advice or a quotation?
application@krohne.com

The current list of all KROHNE contacts and addresses can be found on our website.



www.krohne.com



APPLICATION REPORT

Leak management system with GPRS remote monitoring in the Rio de Janeiro drinking water network

- Flow measurement rated to IP68 to check water consumption
- GPRS wireless transmission of readings to create consumption profiles
- Integrated pressure measurement for redundant leak detection

1. Background

In light of the 2016 Olympic Games, expanding the infrastructure in the Brazilian city of Rio de Janeiro is extremely important. Modernising water supply and wastewater disposal is also a focal point. In this context, the Technische Universität Darmstadt (Darmstadt University of Technology) is overseeing a pilot project focusing on improving the ecological efficiency in the Brazilian water industry. The objective is to pinpoint measures to increase energy efficiency when it comes to the supply of water, in cooperation with partners in science and economy. Leak detection is the focal point of the pilot project. Leaks mean water loss – water loss means energy loss – energy loss means high but avoidable additional costs. This was one of the main starting points. The campus of the University of Rio de Janeiro, located on an island near the mainland, was chosen as the venue for the pilot project. The municipal provider made the local water supply system available for the purpose of analysis. This system supplies around 2000 residents in a selected neighbourhood with drinking water.



University of Rio de Janeiro campus

2. Measurement requirements

The pilot project will involve investigating how flow technology can be used to determine the actual water consumption as well as any potential water loss caused by leaks. This application required a leading technological measurement solution suitable for continuous and highly accurate flow measurement and that features an integrated pressure sensor for redundant leak detection. The readings should also be provided via GPRS remote transmission to a control centre where exact consumption and supply pressure profiles are created. Since installation is to take place at freely accessible measuring points and the equipment will thus be exposed to environmental and other influences, the measuring instrument used had to be sturdy and feature an integrated GPRS module and maximum water tightness as per IP68.



WATERFLUX with GPRS module KGA 42 in aboveground part of the pipeline

3. KROHNE solution

KROHNE was selected as the technology partner for the pilot project. They supplied two WATERFLUX 3070 C electromagnetic water meters and two KGA 42. The devices were provided in the IP68 version in order to operate them under water. The measuring instruments were installed in the aboveground, easily accessible parts of the main supply line (DN 100 / 4") and in a bypass (DN 50 / 2") of the water network in the neighbourhood. Both water meters are equipped with integrated pressure and temperature sensors.

Based on flow and pressure measurements, the WATERFLUX provides continuous information about the daily and nightly water consumption as well as the supply pressure in the water line. An external GPRS module KGA 42 serves to wirelessly transmit the readings for the pilot project. To analyse and visualise the readings both the internet-based system WebKGA as well as the software-based mini SCADA system PCWin will be tested at the same time. Possible errors, critical battery levels and preset thresholds trigger an alarm in the control room via SMS or email.

APPLICATION REPORT

Replacing the WATERFLUX later for safety reasons with a device variant featuring an integrated GPRS module was defined as a milestone for the project. In addition to accurate flow measurement, the fully compact measuring device in protection category IP 68 offers an integrated pressure and temperature sensor, an integrated data logger and a GSM module. The readings are then transferred to the control room via GPRS. Wiring outside of the measuring device is now no longer necessary. Sealing options and a software menu lock provide protection against manipulation or unauthorized access.



Schematic layout of measuring points with GPRS module

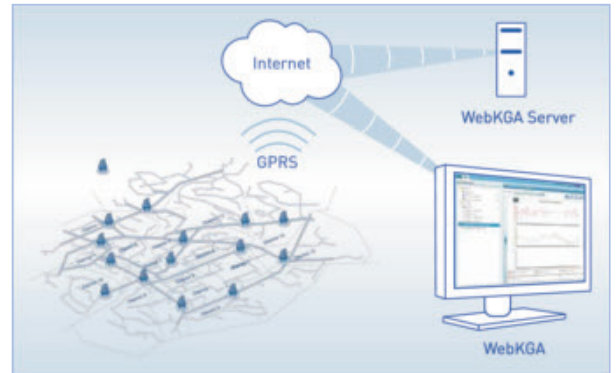

GPRS transmission with WebKGA

4. Customer benefits

The WATERFLUX 3070 C can be used to accurately analyse water consumption during the day and overnight. The KROHNE device helps properly determine usage patterns for about 450 households. For example, after just a short time using the WATERFLUX readings it was possible to create accurate consumption profiles, which pointed to unusually high but constant night consumption. Using the WATERFLUX integrated pressure measurement it is possible to check for connections to leaks or other process interventions. In this way, the WATERFLUX indicates how to efficiently manage the water supply network, detecting water losses quickly. This permits resource protection and permanent cost reductions.

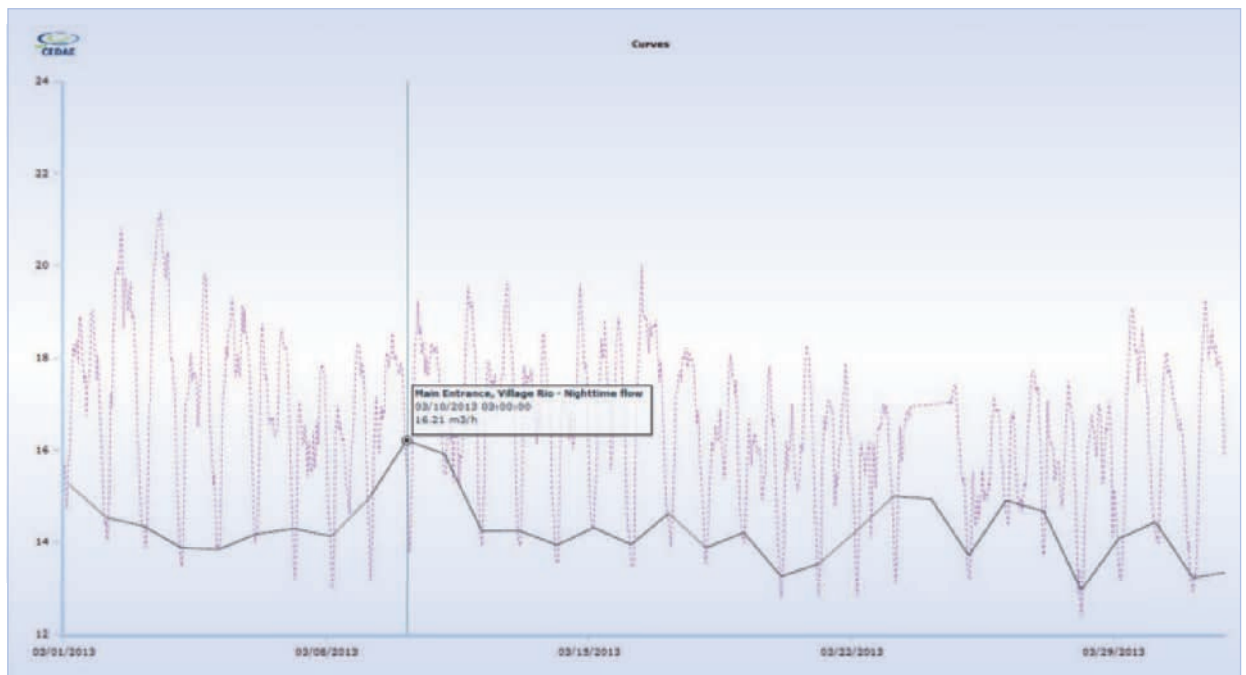

Load curve (consumption profile) in a month (Day = red / night = black)



Use of WATERFLUX in partially flooded areas



Measuring tube supported by gravel bed

5. Products used

WATERFLUX 3070 C

- Battery-operated stand alone water meter with integrated pressure and temperature measurement
- Suitable for custody transfer according to OIML R-49 and MI-001
- No wear, no deposits
- Bi-directional measurement; no inlet and outlet runs necessary
- Compact version in protection class IP68
- Sizes DN 25...600 / 1"...24", Rilsan polymer coating
- Remote monitoring with integrated GSM module or external KGA 42 (GPRS)
- Data analysis by way of web-based system WebKGA or software-based mini SCADA system PCWin



KGA 42

- Data logger and GSM antenna for remote transmission of readings
- 4 digital and 2 analogue inputs
- Strong GSM signal specially designed for manholes
- For installation sites with no power supply
- Standard protection category IP68



WebKGA

- Secure server-based remote monitoring system for small and large water networks
- Access via any PC with internet browser
- High data security thanks to redundantly secured data processing centre
- Unlimited number of measuring points can be monitored

PC Win

- PC-based remote monitoring software with local GSM modem
- Comprehensive mini SCADA system
- Up to 250 measuring points can be monitored with one workstation

Contact

Would you like further information about these or other applications?
Do you require technical advice for your application?
application@krohne.com

Please visit our website for a current list of all KROHNE contacts and addresses.



www.krohne.com



Marine

- Ultrasonic flow measurement of hydrocarbon vapors..... 80
- Fuel consumption monitoring and reporting on LPG tankers..... 82
- Fuel consumption and emission monitoring on a hospital ship..... 84



APPLICATION REPORT

Ultrasonic flow measurement of hydrocarbon vapors

- Ultrasonic flowmeters for a vapor processing and cleaning unit at a terminal
- Flow measurement of low-pressure gases from storage tanks
- Monitoring of liquid vapors with high variations in gas content
- Bidirectional measurement over a large dynamic measuring range



1. Background

New laws and regulations require terminals to collect and process vapors released during the storage and transfer of refined hydrocarbons such as fuel oil. Koole Tankstorage Minerals (KTM), an independent international storage and transport company, has designed a new vapor processing unit to keep emissions at their tank terminal in Pernis, the Netherlands, well below the legal emissions threshold.

2. Measurement requirements

The unit is designed to process and treat all vapors extracted from the fuel oil tanks. The cleaned vapors end up in the incineration section where they are flared off in a fully autothermal process without using any additional fuel gases.

During the loading and unloading procedures, the vapors are extracted and transported to the vapor processing unit with blowers at almost ambient pressure conditions. The vapor composition depends on how the liquid hydrocarbons are stored, pumped or transported. Due to temperature changes, the gases can contain moisture or even liquid drops. Tanks may be rendered inert by means of gases like N_2 or even CO_2 to prevent hazardous conditions or product oxidation during transport, which in turn also has an impact on the vapor composition. The vapor flow rates can vary greatly. If products are not moved, the flow velocity is very low. When numerous seagoing vessels are loaded or unloaded at the same time, however, vapor flow rates can rise steeply.

To control the system and check continuously on leakages, it is important that every vapor entry point is monitored by a flowmeter. The customer was therefore searching for a flowmeter able to measure the vapors extracted from the fuel oil storage tanks over a wide dynamic range. It was required that pressure drops be avoided. Bidirectional measurement was mandatory for the various measuring points. As the vapor processing unit must always be available and operational, low maintenance or long calibration intervals of the flowmeter were considered crucial.



3. KROHNE solution

KROHNE supplied several OPTISONIC 7300 ultrasonic gas flowmeters for the vapor processing unit. The OPTISONIC 7300 is ideally suited for flow measurement of vapors and gases over a large dynamic range and largely independent of gas density and composition.

Following initial calibration, the device provides accurate measuring results over time. The standard measuring range is between -30 and 30 m/s within a performance of $\pm 1\%$ for flow rates > 1 m/s. The gas flowmeter features a full-bore design without any moving or intruding parts, thus causing no pressure loss.

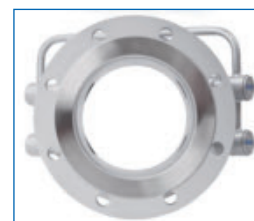

Full bore design of the OPTISONIC 7300 ultrasonic flowmeter



Ultrasonic flow measurement of hydrocarbon vapors

4. Customer benefits

The air emitted is now in fact clean and hydrocarbon emissions are also minimized significantly, demonstrating the potential of KTM's sophisticated solution. With the use of the OPTISONIC 7300 flowmeter, the storage company always knows how much vapor is coming from where. In this way, the vapor processing unit can be effectively monitored and controlled. Next to the dynamic flow rate, the gas velocity of sound can also be continuously measured and provided by the KROHNE flowmeter via a second output. Since the mol weight is directly proportional to the velocity of sound, it can be calculated and used by the customer to optimise the burning process.

KTM benefitted from KROHNE's long-lasting application expertise in ultrasonic gas flow measurement. Not only are the algorithms of the OPTISONIC 7300 optimised for those difficult process conditions, also the acoustic transducer frequency was optimised for this application to maximise signal strength leading to a highly reliable measurement at the almost ambient pressure conditions.

The OPTISONIC 7300 also meets the customer requirements for plant availability. The ultrasonic flowmeter remains drift-free over time and impact of liquid droplet and CO_2 concentration are minimal. The flowmeter is maintenance-free by design. A periodical recalibration is not required. Wear or restrictions in terms of dynamic measuring range are also not an issue.

5. Product used

OPTISONIC 7300 C

- Ultrasonic flowmeter for hydrocarbon vapors and other gases
- High accuracy ($\pm 1\%$ of MV), independent of gas composition
- Large dynamic range (turndown ratio: 100:1)
- Maintenance-free, no pressure loss, no need for periodical recalibrations



Contact

Would you like further information about these or other applications?
Do you require technical advice for your application?
application@krohne.com

Please visit our website for a current list of all KROHNE contacts and addresses.



www.krohne.com



APPLICATION REPORT

Fuel consumption monitoring and reporting on LPG tankers

- Complete overview of consumers on board to increase efficiency and reduce emissions in accordance with EU MRV and IMO
- Combined solution of monitoring system and Coriolis mass flowmeters
- Continuous and accurate data on mass flow, temperature and density of LNG and MGO fuels for main and auxiliary engines
- Engineering, service and support from KROHNE Marine, installation by ship owner



1. Background

The Anthony Veder Group is an integrated shipping company specializing in gas tankers. Operating their first gas tanker in 1969, their current fleet counts 31 vessels carrying all segments of the gas market from CO₂ to ethylene and LPG to LNG. Among others the company operates the LPG tankers Coral Star and Coral Sticho.

2. Measurement requirements

Both vessels have dual fuel engines powered by MGO and LNG. Rising fuel costs and more demanding regulations have made fuel efficiency and emission control a concern for ship operators. EU MRV and IMO regulations require operators and owners to monitor fuel consumption of all consumers on board and report the verified amount of CO₂ emitted by their vessels. This makes ship-specific monitoring a high priority, which requires clear and consistent daily, weekly and monthly fuel consumption data.

Anthony Veder was therefore searching for a complete monitoring solution for Coral Star and Coral Sticho. All information and reporting related to fuel consumption and carbon emissions were to be provided in one system while utilizing various flow measurements on board. This also included the installation of additional flowmeters as the customer had MGO consumption monitoring on the main engine only, using a gear-type volumetric flowmeter. The LNG flow rates to the main engine and the auxiliary engines as well as the MGO used for the auxiliary engines were not monitored.



3. KROHNE solution

Anthony Veder Group decided in favour of a solution combining the EcoMATE™ fuel consumption and carbon emission monitoring system with Coriolis mass flowmeters. The KROHNE Marine scope of supply also included a marine approved computer, communication hardware (I/O box with power supply, signal interface) and printers for reports.

Three units of the OPTIMASS 6400 F Coriolis mass flowmeter were installed in the LNG fuel supply lines (DN15...25). With its wide temperature range (down to -200°C / -328°F) this flowmeter is particularly suitable for LNG and other cryogenic liquids. One OPTIMASS 1010 Coriolis mass flowmeter was mounted in the MGO fuel supply line (DN15) to one of the auxiliary engines. All flowmeters have DNV GL Marine approvals as required by the customer.



Comprehensive overview of consumers on board provided by EcoMATE™

EcoMATE™ uses the mass, density and temperature measurements of the Coriolis mass flowmeters as well as the signal from the existing gear-type volumetric flowmeter. In this way, EcoMATE™ enables onboard monitoring and reporting of fuel consumption, providing key emission data in accordance with EU MRV and IMO requirements.

4. Customer benefits

In combination with the Coriolis mass flowmeters the EcoMATE™ monitoring system provides the customer with continuous, reliable and accurate data on both LNG and MGO consumption on their ships. The acquired data helps the on board crew optimize engine performance and reduce emissions. EcoMATE™ provides configurable reports for easy compliance with EU MRV and IMO emissions registration per voyage.

KROHNE Marine worked in close cooperation with Anthony Veder to find the optimum solution for their vessels. From consultation and project management to the supply of the monitoring system and Coriolis flowmeters to the integration of the whole system into the existing infrastructure of the customer – everything has been provided from one source. This also involved the seamless integration of the existing volumetric flowmeter into the EcoMATE™ system which saved costs and installation time.

5. Solution and products used

EcoMATE™

- Fuel consumption and carbon emission monitoring system for ships
- MRV compliant and verified acc. to EU regulation 2015/757



OPTIMASS 6400 F

- Coriolis mass flowmeter for bunkering and fuel consumption measurement
- High accuracy mass, density and volume flow measurement (optional $\pm 0.05\%$ of MV)
- Various marine approvals (CCS; DNV GL; RINA etc.)



OPTIMASS 1010

- Coriolis mass flowmeter for bunkering and fuel consumption measurement
- Twin straight tube; compact installation with integrated Modbus converter
- Various marine approvals (CCS; DNV GL; RINA etc.)



Contact

Would you like further information about these or other applications?
Do you require technical advice for your application?
application@krohne.com

Please visit our website for a current list of all KROHNE contacts and addresses.





Courtesy of Mercy Ships

APPLICATION REPORT

Fuel consumption and emission monitoring on a hospital ship

- Reliable consumption data of main engines and generators
- Emission monitoring in compliance with EU and IMO regulations
- Full service package from monitoring system and flowmeters to implementation, support and integration into cloud services



1. Background

The international charity Mercy Ships operates the world's largest civilian hospital ship "Africa Mercy". The "floating" hospital provides free surgeries and healthcare to people with little or no access to healthcare in Africa. First-rate medical care is provided by a crew of 400 volunteers from around the world.

2. Measurement requirements

Fuel consumption monitoring of the ship's main engines and generators is crucial to the organisation's effort to increase energy efficiency and to reduce emissions. Ciaran Holden, Engineering Superintendent at the Africa Mercy, was searching for a monitoring solution that allowed the charity to comply with EU MRV and IMO regulations to monitor, report and verify the vessel's emissions in terms of CO₂.

3. KROHNE solution

KROHNE provided the EcoMATE™ fuel consumption and carbon emission monitoring system in combination with 6 OPTIMASS 1010 Coriolis mass flowmeters. The twin straight tube flowmeters (size DN15, made from stainless steel) were installed in the supply lines to the two main engines and the generators as well as the corresponding return lines.

All readings are transferred via Modbus to the EcoMATE™ system that uses the mass, density and temperature measurements of the flowmeters. In this way, EcoMATE™ enables on-board monitoring and reporting of fuel consumption, providing key emission data in accordance with EU MRV and IMO requirements. In addition, all actual readings are made available via the EcoMATE™ Cloud module to allow monitoring and analysis of consumption data at remote onshore stations. KROHNE also supplied all other necessary components such as a marine approved computer with 23" monitor, a 12" bridge panel computer for bridge mounting as well as equipment for power supply and printers for reports.

KROHNE

4. Customer benefits

The combined solution of EcoMATE™ and OPTIMASS 1010 flowmeters provides Mercy Ships with accurate daily, weekly and monthly consumption data on board. The fuel consumption of all main engines and generators can be reliably monitored, helping the charity take steps to optimise fuel consumption and reduce emissions.



OPTIMASS 1010 flowmeter on board Africa Mercy

EcoMATE™ also guarantees that EU and IMO's mandatory regulations on the monitoring, reporting and verification (MRV) of carbon dioxide emissions are fully met. Using the EcoMATE™ Cloud module allows the customer to automatically send their consumption data to a cloud solution, enabling on-shore staff to monitor ship specific fuel usage or voyage reports.

As a single source supplier, KROHNE managed the whole project. The full service package involved engineering (incl. drawings and documentation), the adaptation of EcoMATE™ functionality to the individual ship applications as well as commissioning of the solution (incl. installation of flowmeters).

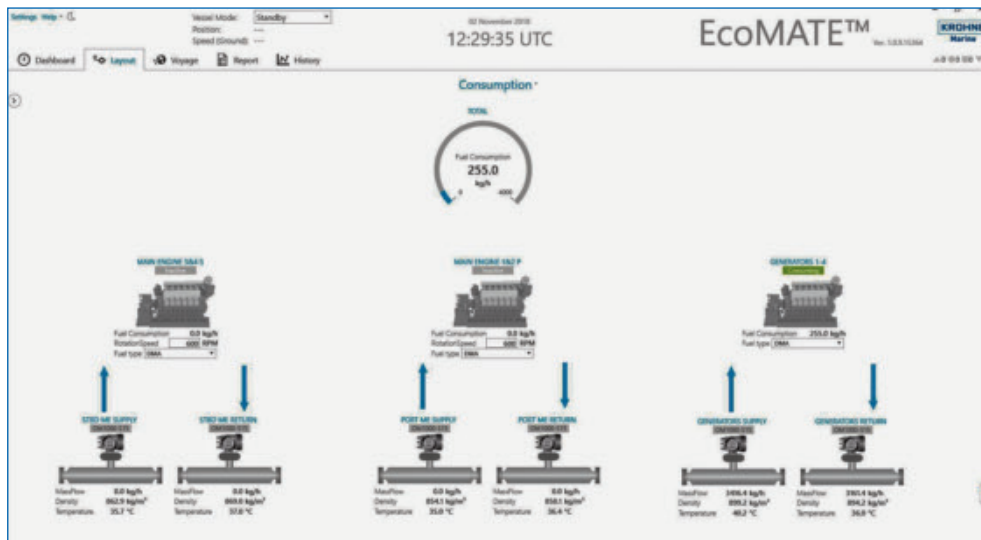

Comprehensive overview of fuel consumption on board provided by EcoMATE™



Flow measurement with OPTIMASS 1010

5. Solution and product used

EcoMATE™

- Fuel consumption and carbon emission monitoring system for ships
- Cloud functionality for remote data transfer to onshore stations
- MRV compliant and verified acc. to EU regulation 2015/75

OPTIMASS 1010

- Twin straight tube Coriolis mass flowmeter for fuel consumption measurement
- Integrated Modbus: No separate converter, communication direct from meter
- Various Marine approvals (DNV GL etc.)



Contact

Would you like further information about these or other applications?
Do you require technical advice for your application?
application@krohne.com

Please visit our website for a current list of all KROHNE contacts and addresses.



www.krohne.com