

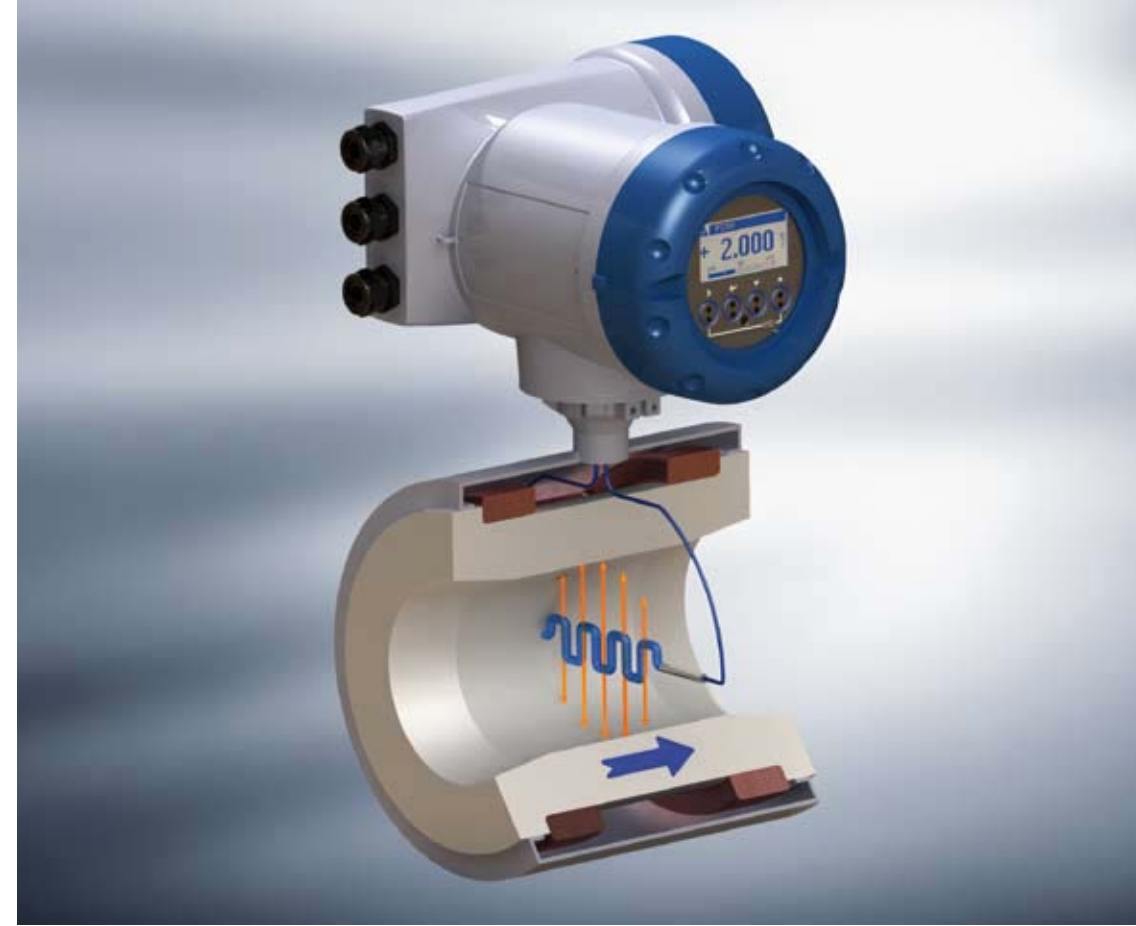

Friedrich Hofmann
As head of development, Friedrich Hofmann (DipEng) was responsible for the first generations of EMFs featuring pulsed direct current fields.
In his more than 30 years with KROHNE, he had a significant influence on the development of electromagnetic flowmeters – from expensive, high-maintenance specialised devices to reliably functioning, maintenance-free standard measuring devices.

Principles of Electromagnetic Flow Measurement



KROHNE

Principles of Electromagnetic Flow Measurement

ETA Process Instrumentation

www.etapii.com
sales@etapii.com
tel 978.532.1330

New England

Martech Controls

www.martechcontrols.com
sales@martechcontrols.com
tel: 315.876.9120

Upstate New York

Principles of Electromagnetic Flow Measurement

Friedrich Hofmann 2011

KROHNE

Imprint

2. Edition 2011

Copyright

KROHNE Messtechnik GmbH

Ludwig-Krohne-Str. 5

47058 Duisburg

info@krohne.de

www.krohne.com

Printed in Germany

In many industries, measuring devices and sensors are an important part of process control technology and in equipping automated plants. The significance of flow measurement is reflected in the variety of measuring methods specifically designed for this purpose.

Because of its many advantages, the principle of electromagnetic flow measurement is especially important.

This book is intended to serve as a general source of information when it comes to the use and technology of electromagnetic flowmeters (EMF). To start off, the reader is introduced to the basics of the electromagnetic flow measuring principle, including its advantages and limitations. Further explanations regarding the theory follow.

This book is also beneficial because of the wealth of information it provides regarding the selection and use of electromagnetic flowmeters.

Many of the recommendations made are based on the author's years of practical experience as well as on the feedback of customers in the KROHNE Group.

However, when it comes to the planning, actual selection and use of the devices and materials, the respective device manufacturer's information and documentation is always binding.

Friedrich Hofmann

List of figures	X
List of tables.....	XIV
KROHNE - The Company	XVII
KROHNE EMF Highlights, a world's first	XVIII
Chapter 1.....	21
The fundamentals of flow measurement	
Chapter 2.....	25
The fundamentals of electromagnetic flowmeters	
2.1. Introduction.....	26
2.2. Measuring principle	27
2.3. Advantages.....	29
2.4. Primary head.....	30
2.5. Signal converter	34
Chapter 3.....	37
EMFs for fully filled pipelines	
3.1. Advantages.....	40
3.2. Limits	44
3.3. Maintenance.....	44
3.4. Testing	46
3.4.1. Testing accuracy test with a calibration rig.....	46
3.4.2. Testing and documentation with testing equipment	46
3.4.3. Intelligent self-diagnostics.....	48
Chapter 4.....	53
EMFs in special areas of applications	
4.1. Explosion protected versions.....	55

4.2. EMFs for custody transfer	59
4.3. EMFs in environments with strong magnetic fields.....	60
4.4. Measuring pulsating flows using EMFs.....	62
4.5. EMFs for products with high solids content.....	64
4.6. EMFs without electrodes with capacitive signal pick-up	70
4.7. EMFs for partially filled pipelines.....	72
4.8. Battery-operated EMFs for remote measuring points.....	74
4.9. Two-wire EMFs.....	79
4.10. EMFs for rapid volumetric filling	83
4.11. EMF probes	91
 Chapter 5.....	 95
Electromagnetic flowmeters – planning	
5.1. Analysing the range of application and the operating conditions.....	96
5.2. Device selection	103
5.3. Installation	110
5.3.1. Primary head.....	112
5.3.2. Signal converter	115
5.3.3. Signal cable	117
5.4. Grounding	118
5.5. Surge Protection	119
 Chapter 6.....	 121
Quality assurance at KROHNE	
6.1. KROHNE burn-in test.....	122
6.2. KROHNE calibration.....	124
 Chapter 7.....	 129
The fundamental principles of fluid mechanics	
7.1. Flow measurement	130

7.2. Basic laws of fluid mechanics	131
7.2.1. Continuity equation	131
7.2.2. Principle of energy conservation	132
7.3. Flows	134
7.3.1. Laminar flows	134
7.3.2. Turbulent flows	136
7.4. The Reynolds number Re	137
7.5. Pressure loss in incompressible flows	138
Chapter 8.....	143
The theory of electromagnetic flowmeters	
8.1. Measuring principle	144
8.2. Physical background	146
8.3. Signal generation and processing	150
8.3.1. Internal resistance.....	150
8.3.2. AC and DC field	150
8.3.3. Signal cables with bootstrap.....	154
8.4. Signal converter in detail.....	157
8.5. Flow profiles.....	160
8.6. Empty pipe detection	167
8.7. Grounding	170
8.7.1. Classic grounding methods – grounding the process liquid.....	170
8.7.2. Newer grounding methods – without grounding the process liquid...	172
8.8. Surge Protection	175
8.9. Norms and standards	179
Chapter 9.....	183
Summary and outlook	
References	186
Index.....	194

List of figures

Fig. 1:	Compact EMF – sandwich version (KROHNE, OPTIFLUX 1300C)	26
Fig. 2:	Measuring principle of electromagnetic flowmeters.....	27
Fig. 3:	Structure of an EMF.....	30
Fig. 4:	World's first EMF with 3 m nominal size (KROHNE M960, 1983)	31
Fig. 5:	EMF – sandwich version (KROHNE, OPTIFLUX 1000)	32
Fig. 6:	EMF – hygienic version with weld-in connections (KROHNE, OPTIFLUX 6000)	33
Fig. 7:	L-shaped gasket with trapezoidal sealing lip	33
Fig. 8:	KROHNE compact EMF, flanged version, with IFC 300 (OPTIFLUX 4300C) signal converter	35
Fig. 9:	KROHNE compact EMF, flanged version, with IFC 100 (OPTIFLUX 2100C) signal converter	35
Fig. 10:	KROHNE's modular EMF product line, signal converters	38
Fig. 11:	KROHNE's modular EMF product line, primary heads.....	39
Fig. 12:	EMF limits of error at reference conditions (KROHNE, OPTIFLUX 5300)	40
Fig. 13:	EMF measuring tube featuring a stainless steel reinforced PFA liner (KROHNE, OPTIFLUX 4000)	41
Fig. 14:	Effects of the flow profile on EMF measuring accuracy, here using a WIB-SIREP-E-1747-S-94 test with a KROHNE EMF with a nominal size of DN 50	42
Fig. 15:	EMF test equipment (KROHNE, MagCheck)	46
Fig. 16:	Monitoring of general error modes using the measuring electrodes.....	49
Fig. 17:	Magnetic field with normal field coil polarity for flow measurement	50
Fig. 18:	Measuring the flow profile by reversing the polarity of the upper and lower field coils.....	50
Fig. 19:	The KROHNE specialists for special applications	54
Fig. 20:	XY metrology marking	60

Fig. 21: Example of the measurement of a pulsating flow, pictured here at the outlet of a diaphragm pump	62
Fig. 22: Wear on pipe connections during hydraulic transport and edges protruding into the pipeline	67
Fig. 23: Protective ring to protect the liner of the EMF during hydraulic transport.....	67
Fig. 24: Flow and concentration profile when hydraulically transported in a horizontal pipeline	68
Fig. 25: Flow patterns during hydraulic transport in long, perpendicular pipelines.....	69
Fig. 26: Structure of an EMF with capacitive signal pick-up	70
Fig. 27: KROHNE TIDALFLUX 4110PF, the world's first EMF for partially filled pipelines featuring non-wetted level measurement	72
Fig. 28: Measuring principle of an electromagnetic flowmeter for partially filled pipelines (KROHNE, TIDALFLUX 4110PF)	73
Fig. 29: KROHNE WATERFLUX 3070C	75
Fig. 30: WATERFLUX 3070C measuring tube	75
Fig. 31: WATERFLUX 3070C battery	77
Fig. 32: Error limits for water meters in accordance with measuring instrument directive 2004/22/EC, Appendix MI-001 and OIML R49	78
Fig. 33: 070C Signal converter for the WATERFLUX 3000.....	79
Fig. 34: Functional principle of multiwire EMFs	80
Fig. 35: Functional principle of two-wire EMFs	81
Fig. 36: KROHNE BATCHFLUX 5015C.....	83
Fig. 37: Volumetric filling with KROHNE BATCHFLUX EMF	84
Fig. 38: KROHNE BATCHCONTROL 5014C.....	85
Fig. 39: Comparison of the wiring involved with a filling machine with a classic EMF and with one BATCHCONTROL.....	86
Fig. 40: Record of a filling process – "valve open"	88

Fig. 41: Results of an independent test investigating the long-term stability of EMFs with PTFE and ceramic measuring tubes, size DN 15, after continuous stress (e.g. 600 changes 18°C / 80°C + hot acid 80°C + superheated steam 140°C) 90

Fig. 42: Electromagnetic flow probe (KROHNE, DWM 2000) 92

Fig. 43: Reduction of the gas volume by increasing pressure, relative gas-volume content standardized to 1 at $p_{abs} = 1$ bar 100

Fig. 44: Reducer upstream and downstream of the EMF 103

Fig. 45: Compact version of a signal converter (KROHNE, IFC 300C) 109

Fig. 46: Wall-mount version of a signal converter (KROHNE, IFC 300W) 109

Fig. 47: Possible measurement errors when inlet runs too short 112

Fig. 48: EMF in compact version (KROHNE, OPTIFLUX 4300C) 115

Fig. 49: EMF remote version (KROHNE, OPTIFLUX 4300W) 115

Fig. 50: Service life of electronics depending on the temperature..... 116

Fig. 51: Burn-in test using the KROHNE IFC 300..... 123

Fig. 52: Setup of KROHNE Altometer calibration rig for EMFs up to DN 3000 125

Fig. 53: Calibration certificate (KROHNE, OPTIFLUX 2000) 126

Fig. 54: Calibration rig (KROHNE, Netherlands)..... 127

Fig. 55: Explanations regarding the basic laws of fluid mechanics 133

Fig. 56: Example of layers of fluids 135

Fig. 57: Laminar flow 136

Fig. 58: Turbulent flow 136

Fig. 59: Flow resistance 138

Fig. 60: Measuring principle of electromagnetic flowmeters..... 145

Fig. 61: x-component of valence vector W according to Shercliff on the electrode level 148

Fig. 62: Typical time characteristic of field current and electrode voltage in an EMF with pulsed dc field..... 153

Fig. 63: Line capacitance and signal distortion in longer signal cables
without single conductor shields 154

Fig. 64: Line capacitance and signal distortion for signal cable with
shielding (Bootstrap) 155

Fig. 65: Block diagram of an EMF signal converter (KROHNE, IFC 300)..... 158

Fig. 66: Smoothing the flow profile by reducing
the measuring cross section (PTB Berlin, 1991) 160

Fig. 67: Measurement errors downstream of a partially open
valve in inlet runs of 1D and 5D 161

Fig. 68: Distorted flow profile downstream of an elbow 163

Fig. 69: Distorted flow profile downstream of a sudden expansion..... 163

Fig. 70: Swirl flow caused by an out-of-plane double bend..... 164

Fig. 71: Grounding the process liquid in metal pipelines
not coated on the inside..... 170

Fig. 72: Grounding the process liquid in pipelines
with electrically insulated walls 171

Fig. 73: Virtual grounding via the device electronics when installing
the EMF in pipelines with insulated walls..... 173

Fig. 74: Surge Protection in a compact EMF version 177

Fig. 75: Surge Protection in a remote system EMF version 178

List of tables

Table 1:	Diagnostic requirements for EMFs as per VDI / VDE 2650, Sheet 3.....	47
Table 2:	KROHNE's IFC 300 diagnostic tools which exceed VDI / VDE 2650 requirements.....	48
Table 3:	Preconditions for an explosion.....	56
Table 4:	Equipment categories for gas and dust atmospheres.....	57
Table 5:	Classification of hazardous operating areas.....	58
Table 6:	Recommendations for selecting the sizes of BATCHFLUX and BATCHCONTROL depending on filling volume and flowrate.....	89
Table 7:	Examples of process liquids in different industries.....	96
Table 8:	Selection criteria for the design of EMF devices	105
Table 9:	Overview of measuring tube and liner materials for EMFs.....	106
Table 10:	Suitable electrode materials depending on process liquid	108
Table 11:	Criteria for selecting signal converter version	110
Table 12:	Suggestions for selecting a suitable installation site for the primary head	111
Table 13:	Determining the pipe friction coefficient in turbulent flows	140
Table 14:	Smoothing effect of a reducer (KROHNE, OPTIFLUX 5000)	162

Ludwig Krohne & Sohn in Duisburg started manufacturing variable area flowmeters in 1921.

The variable area flowmeters that came later made it possible to adjust the gas/air mixture for optimal combustion.

The small family business survived the world financial crisis from 1928 to 1932 and the Second World War.

Kristian Rademacher-Dubbick, a nephew of company founder Ludwig Krohne, took over the family business in 1948. At the time the company had only 12 employees.

Subsequent years saw intensive development in research and sales strategies. The once small family business grew into one of the world's leading manufacturers of measuring devices:

KROHNE Messtechnik.

From an early stage, KROHNE focused on measuring devices for industrial use. Both the company history and being situated in one of the most industrialised regions in Europe justified KROHNE's choice of industrial measurement technology as its core business. It all started with variable area flow measurement.

KROHNE was the first manufacturer to successfully calculate and form cylindrical glass tubes into tapered measuring tubes. The tolerances were sufficiently reduced to make the measuring tubes interchangeable. The calculation method for glass cones developed by KROHNE went on to form the basis for the VDI/VDE 3513, Sheet 2 directive. This method allowed the flow display to be converted as the properties of the process liquid changed.

In 1962, KROHNE took over the company "Alto", previously known as "Tobi", which was based in Rotterdam and renamed it KROHNE Altometer. At the time Tobi or Alto was the world's first manufacturer of electromagnetic flowmeters (EMF) for industrial use.

Over time, KROHNE expanded into many other areas of industrial measurement technology including:

Ultrasonic flow measurement

EMFs require electrically conductive liquids. In 1983, KROHNE developed the world's first ultrasonic flowmeter (UFM) for non-conducting media featuring two parallel measuring beams. These devices exhibit smaller measurement error during changes in the flow profile than single beam UFM. In 1999, with the 5-beam UFM ALTOSONIC V, KROHNE attained the world's first approval for a UFM suitable for the custody transfer of all liquids other than water. This approval guarantees a measurement error of less than $\pm 0.2\%$ across a measuring span of 10:1.

Coriolis mass flow measurement

KROHNE has been setting the benchmark with Coriolis mass flowmeters (CFM) as well. In 1986 the CORIMASS S was the world's first CFM to feature a single loop measuring tube and boast highly precise digital signal processing supported by a microprocessor. In 1994, KROHNE introduced the world's first CFM featuring a single straight tube.

Level measurement

In 1989, KROHNE introduced the world's first non-contact radar level measurement system (FMCW) for process tanks. The BM 70 made it possible to measure the precise level in the presence of turbulent liquid surfaces, stirring devices and built-in components in the tank as well as when dust, steam or mist are in the atmosphere.

Expanding the product range

Over recent years, KROHNE has expanded its range of products to include sensors for pressure, temperature and analysis.

KROHNE Oil & Gas

KROHNE Oil & Gas develops and supplies products, systems and engineering services for bulk measurement, management and monitoring.

KROHNE Water Solutions

KROHNE Water Solutions specialises in complete measurement solutions for the water and wastewater industry.

KROHNE Skarpenord

KROHNE Skarpenord offers complete solutions including cargo handling and ballast monitoring systems for seagoing vessels.

- 1967** The short model EMF features a modified inhomogeneous magnetic field, is more reasonably priced and easier to install.
- 1968** EMFs for hazardous areas can also be used in the chemical industry.
- 1974** The introduction of the pulsed dc field with automatic zero correction means that for the first time ever, EMFs are stable, maintenance-free precision measuring devices.
- 1978** The first EMF with a proper, fully digital measuring range setting is developed.
- 1979** The largest calibration rig for nominal sizes up to DN 3000 / 120" with a measuring uncertainty of less than 0.05% is approved for official calibration.
- 1980** For the first time, EMFs with pulsed dc field replace high-maintenance ac field EMFs even in the pulp and paper industry.
- 1982** The first sandwich EMF, featuring an Al₂O₃ ceramic measuring tube and fused-in-place platinum electrodes, allows use with chemicals and provides superior stability, even with small nominal sizes.
- 1983** The world's largest EMF with a nominal size of DN 3000 / 120" and a measuring range of over 100,000 m³/h for drinking water and wastewater is built.
- 1984** The first µP signal converter featuring full digital signal processing is launched.
- 1985** The first µP signal converter in a flameproof enclosure (Ex-d) can be adjusted and replaced in hazardous areas.
- 1991** KROHNE becomes the world's first EMF manufacturer to obtain ISO 9001 certification.
- 1992** The first EMF with an optimised flow profile measuring tube is developed. The high degree of measurement accuracy convinced calibration bodies around the world to install it.
- 1993** For the first time, an EMF with aseptic and modular connection adaptors is introduced into the food and beverage industry. It is

simple, flexible and cost-efficient to use.

- 1994** First EMF with a ceramic measuring tube for volumetric filling. It is equipped with fused-in-place CERMET electrodes and exhibits outstanding test results on filling machines.
- 1995** EMFs with pulsed dc field make it possible to measure rapid pulsating flows without a pulsation dampener.
- 1996** The first EMF for partially-filled pipelines with capacitive level measurement is less sensitive to coating.
- 1997** The first EMF with vibration resistant capacitive signal pick-up for the measurement of liquids with minimal electrical conductivity (up to 0.05 $\mu\text{S}/\text{cm}$).
- 1998** Flexible, modular Ex-i design for all inputs and outputs, including PROFIBUS® and FOUNDATION™ Fieldbus.
- 1999** The new, large calibration rig featuring a measuring uncertainty of 0.04% and suitable for nominal sizes up to DN 3000 / 120" is accredited according to EN 17 025 and also approved for official calibrations.
- 2001** The first 2-wire EMF featuring intelligent energy optimisation and integrated noise filters. Ex-i, Ex-e, and Ex-d approvals make the use of 2-wire technology possible in almost any EMF application.
- 2004** The new IFC 300 signal converter exceeds NAMUR NE 107 and VDI/VDE 2650 diagnostic directives, complies with Ex-e, Ex-d, Ex-i and has a measuring accuracy of $\leq 0.15\%$. The IFC 300 is compatible with almost all primary heads manufactured by both KROHNE and other manufacturers since 1974.
- 2005** The introduction of flanged versions for ceramic EMFs simplifies installation.
- 2006** The new, patented virtual grounding makes it possible to eliminate expensive grounding rings made of special materials, thus making installation easier.

1. The fundamentals of flow measurement

KROHNE

1 The fundamentals of flow measurement

Superior measuring technology is now a prerequisite for accurate processes, e.g., when dosing or metering liquid or gaseous products.

In addition to temperature and pressure, flow is one of the most important measurements in many processes.

Flow measurement also involves measuring volume V and mass m . These two measured values are dependent on the density ρ :

$$(1) \quad \text{Density } \rho = \frac{\text{Mass}}{\text{Volume}} = \frac{m}{V}$$

In most processes, instantaneous values are required, i.e., the flow as volume or mass per unit of time, e.g., in m^3/h or in kg/min . Thus, q_v represents the volume flow and q_m the mass flow.

Many flowmeters are equipped with totalisers to control filling processes. These can be programmed as preset counters, for example, to control filling processes. When totalising the quantity, the flow q is integrated from time t_1 to t_2 :

$$(2) \quad V = \int_{t_1}^{t_2} q_v(t) dt$$

$$(3) \quad m = \int_{t_1}^{t_2} q_m(t) dt$$

The mass m is independent from temperature and pressure. However, the volume V and the density ρ of liquids are slightly dependent on temperature. The effect of temperature and pressure is even greater on gases. Here the flow values are referred to a standard state, e.g. at 20°C and 1.013 bar .

For a short introduction to the fundamental principles of fluid mechanics see **Chapter 7**.

2. The fundamentals of electromagnetic flowmeters

KROHNE

2.1. Introduction

Electromagnetic flowmeters (EMF) can measure the volume flow of liquids, slurries, sludges and pastes in almost any industry. The only prerequisite to use an EMF is that the product being measured must have minimum electrical conductivity.

EMF devices such as those pictured in **Fig. 1** are used in fully filled pipelines.

Special designs also make flow measurement possible in partially filled pipelines.

Typical process liquids include:

- Drinking water and wastewater;
- Beer, milk, beverages;
- Acids and caustics, also in high concentrations;
- Sludge from sewage treatment plants;
- Pulp suspensions, pulp;
- Ore and dredger waste with solid particles and rocks.

Fig. 1: Compact EMF – sandwich version (KROHNE, OPTIFLUX 1300C)



2.2. Measuring principle

Electromagnetic flow measurement is based on Faraday's Law of Induction. The law states that voltage is induced across a conductor moving through a magnetic field. The functional principle of electromagnetic measuring devices is also based on this law of nature.

When an electrically conducting liquid flows through the magnetic field of an EMF, voltage is induced as shown in Fig. 2.

The process liquid in the tube with diameter D flows through a magnetic field positioned perpendicular to the direction of flow and with a strength of B . The movement through the magnetic field causes an electrical voltage to be induced in the process liquid. This induced voltage U is proportional to the flow velocity \bar{v} and thus also to the volume throughput.

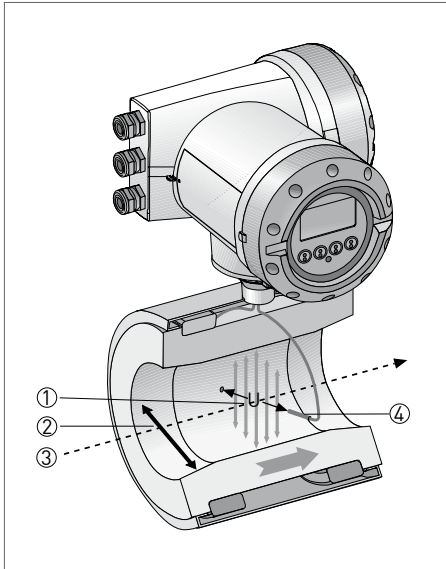

Fig. 2: Measuring principle of electromagnetic flowmeters

- ① B = induction (magnetic field strength)
- ② D = tube diameter
- ③ \bar{v} = mean flow velocity
- ④ U = voltage = $k \times B \times \bar{v} \times D$
 k = meter constant

2 The fundamentals of electromagnetic flowmeters

The following applies (simplified) for the voltage U :

$$(4) \quad U = k \cdot B \cdot \bar{v} \cdot D$$

where

k device constant

B magnetic field strength

\bar{v} mean flow velocity

D tube diameter

For a circular tube cross section the following applies:

$$(5) \quad q = \bar{v} \cdot \pi \cdot D^2 / 4$$

The indicated volume flowrate q_i can thus be determined as follows:

$$(6) \quad q_i = U \cdot \frac{\pi \cdot D}{4 \cdot k \cdot B}$$

The induced voltage signal is picked up using two electrodes that are in contact with the process liquid and then supplied to a signal converter. This signal converter then eliminates interfering signals and amplifies the measured value to make suitable measurement signals available

at its outputs for process control, e.g. active output current of 4–20 mA.

The signal converter supplies the two field coils with an active square wave current and the field coils then generate the primary head magnetic field. This current supplies alternating positive and negative values. Alternating positive and negative flow-proportional signal voltages U_i are created by the alternating magnetic field strength B . The signal converter subtracts these positive and negative signal voltages present at the electrodes from one another. This process always occurs when the field current has reached its stationary value, suppressing the induced interfering voltages and slowly changing (compared to the measuring cycle) external or noisy voltages.

For a thorough introduction to the theory of the electromagnetic flow principle, refer to **Chapter 8**.

2.3. Advantages

The principle behind electromagnetic flow measurement offers a variety of advantages which are briefly explained below.

EMF devices enable the linear display and totalising of volume flow in both flow directions. The measurement is virtually unaffected by pressure, density, temperature, viscosity and flow profile.

Because the magnetic field occupies the entire cross section of the measuring tube that the process liquid flows through, each of the moving volume elements adds to the signal voltage U . This means that the flow profile is averaged over the entire cross section of the tube. This in turn means that only short inlet and outlet runs are required.

EMFs also feature very high measuring accuracy. Depending on the version, the error under reference conditions can be less than 0.15% of the measured value. Because of the high degree of repeatability a standard deviation of less than 0.03% of the measured value is achieved. Measuring ranges of more than 100 : 1 can be achieved with errors of less than 1% of the measured value.

Because of the many modular interfaces that can be combined, such as

- local display of flow and quantity (totalising);
- mA, pulse and status outputs, as well as control inputs;
- HART®, FOUNDATION™ Fieldbus, PROFIBUS®, etc.

it makes it possible to easily integrate the measurement into system environments.

The unobstructed tube cross section prevents any additional loss of pressure. Even when the process liquid contains solid particles, the risk of damage through abrasion is limited because with EMFs there are no parts protruding into the tube. When it comes to abrasive or even aggressive products, there is a broad range of materials available for the wetted parts.

Since EMFs do not have any moving mechanical parts, they are virtually maintenance free. Consequently, they are extremely reliable, have a long service life and boast superior long-term stability and availability.

2.4. Primary heads

The following describes the structure and the most important components of the primary head in an electromagnetic flowmeter. Its most important components are shown in **Fig. 3**.

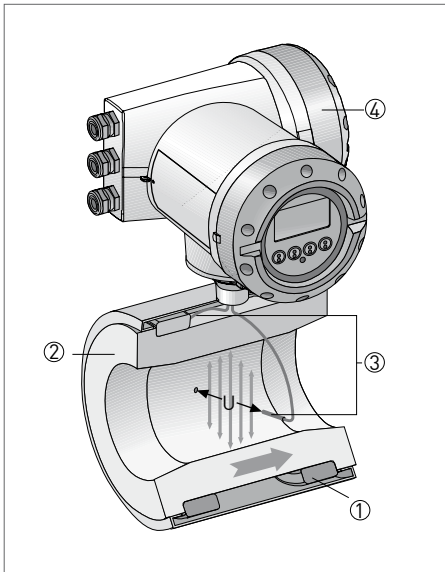

Fig. 3: Structure of an EMF

- ① Field coils
- ② Measuring tube
- ③ Electrodes
- ④ Signal converter

Field coils

The field coils are protected within the housing of the primary head. They are diametrically fastened to the measuring tube and perpendicular to the electrode axis. The supply that generates the

magnetic field comes from the signal converter.

Measuring tube

The magnetic field generated by the field coils located on the measuring tube must be able to penetrate the process liquid through the wall of the tube. For this reason, the measuring tube may not be made of a ferromagnetic material. Neither may the inner wall of the tube be electrically conducting, so that the signal voltage induced in the process liquid cannot be short-circuited. The measuring tube is thus normally made out of ceramic, plastic or non-ferromagnetic stainless steel with an electrically insulating liner or internal coating. The interior wall of the tube comes in contact with the process liquid and must thus be corrosion-resistant to the process liquid.

For an overview of common materials and their fields of application, see **Table 9** in **Section 5.2**.

Electrodes

The electrodes are in direct contact with the process liquid and must therefore be corrosion resistant while ensuring good electrical transfer to the process liquid.

For common materials and their field of application, refer to **Table 10** in **Section 5.2**.

One exception is the capacitive electrodes that measure without liquid contact. For more information on this topic see **Section 4.6**.

Designs

The primary heads for electromagnetic flowmeters are available in a variety of versions. They include:

- Flanged version;
- Sandwich version;
- Hygienic version.

See below for a more in-depth look at the designs, properties and range of applications.

Flanged version

This is the most common version for installing the EMF into a process line. The flanges are available in a variety of nominal sizes and pressure ratings

according to EN, ASME, ISO, JIS, etc. standards. **Fig. 4** shows the possible nominal sizes.



Fig. 4: World's first EMF with 3 m nominal size (KROHNE M960, 1983)

With the flanged version, the EMF measuring tube is usually made of non-ferromagnetic stainless steel. Typical materials for the liner include hard rubber, polypropylene, polyurethane and fluoropolymers such as PFA, PTFE and ETFE. Ceramic measuring tubes are also possible up to a nominal size of 300 mm or 12".

Sandwich version

With this version, pictured in **Fig. 5**, bolts are used to clamp the EMF between the pipeline flanges, which is why this type of EMF is often referred to as the "sandwich" or "wafer" version.



Fig. 5: EMF - sandwich version (KROHNE, OPTIFLUX 1000)

In principle, all liner and measuring tube materials used for the flanged versions can also be used. This may include, for example, stainless steel measuring tubes with a PFA liner (OPTIFLUX 1000) or measuring tubes made of non-porous zirconium oxide ceramic (OPTIFLUX 5000). The highly stable form

and low thermal expansion coefficient of ceramics guarantee high measuring accuracy and long-term stability, even when the process liquids are at a high temperature. In addition, the tapered form of the ceramic measuring tube smooths out severely distorted flow profiles, thus significantly reducing measurement errors in unfavourable installation conditions.

Hygienic version

In the food and beverage industry as well as in pharmaceuticals, all fittings must be free of crevices to ensure that no bacteria can grow and multiply. It must therefore be possible to clean and sterilise EMFs using chemical processes (CIP) and steam (SIP).

The materials used may not release any foreign particles into the process liquid and must be, for example, FDA approved and suitable for the food industry. For this reason, PFA and PTFE are generally used as liner materials. KROHNE's ceramic measuring tubes are also FDA compliant.

Depending on plant standards, the process connections used must comply with a variety of standards. This may include, for example, dairy or SMS connections, clamps, hygienic flanges, etc. Weld-in connections are also possible. **Fig. 6** shows the OPTIFLUX 6000, a hygienic version from KROHNE.



Fig. 6: EMF - hygienic version with weld-in connections (KROHNE, OPTIFLUX 6000)

The EMF connection adaptors are welded directly into the open pipeline. The sealing between the tube liner and the process pipe is achieved with a gap-free L-shaped gasket with a trapezoidal lip as illustrated in **Fig. 7**.

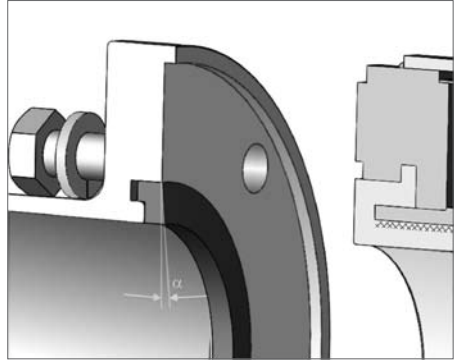

Fig. 7: L-shaped gasket with trapezoidal sealing lip

The OPTIFLUX 6000 was redesigned in 2003 to conform to the current EHEDG guidelines. Both the hygienic design and the cleanability of the measuring device were tested. These tests ensure that the EMF is suitable for hygienic applications. Those areas where product residue can be deposited or where microbes can build up during production are tested in particular.

2.5. Signal converter

One of the tasks of a signal converter is to supply the current required by the primary head field coils to generate the magnetic field. The signal converter is also responsible for the μP -controlled processing of the flow-proportional signal voltage.

This signal voltage U is in the μV to mV range and is subject to noise and interference voltages. The converter's signal processing converts this voltage into digital values and digitally filters the noise and interference signals out. From this filtered signal, the flow velocity \bar{v} and the volume flow q_v are calculated using scaling of the calibration constant and the nominal size of the primary head.

The signal converter can also provide a variety of diagnostic data including the conductivity of the process liquid, indication of the flow profile, etc. The output of the data measured can then be visually displayed on the local display or in analogue form via the **mA current** output as well as in binary form by way of frequency, pulse and status

outputs. In addition, upper range values, units and many other parameters for each output can be individually scaled.

Alternatively, or in addition, the signal converter can transmit measuring or counting values and detailed self-diagnostic information via interfaces such as HART[®], FOUNDATION[™] Fieldbus and PROFIBUS[®]. These analogue and digital interfaces are modular and can be combined with one another, making it easy to integrate into system environments.

KROHNE currently has two signal converters for use with EMFs. One is the IFC 300 which has been on the market since 2004, see **Fig. 8**. The IFC 100 has been available since 2008 and is an option with a very good price–performance ratio. It is an economical measuring solution featuring a high standard of technology, see **Fig. 9**. Both of these converters are compatible with almost any primary head produced both by KROHNE and other manufacturers since 1974.



Fig. 8: KROHNE Compact EMF, flanged version, with IFC 300 (OPTIFLUX 4300C) signal converter

The IFC 300 exceeds the NAMUR NE 107 and VDI/VDE 2650 diagnostic guidelines. It is approved for use in hazardous areas with optional flammable protection type Ex-e as well as Ex-d and Ex-i for the I/O connections. Its measuring inaccuracy is less than 0.15%.

Despite the fact that it looks quite different, the IFC 100 features many of the same functions as its big brother, the IFC 300. Conductivity measurement, the major diagnostic functions and the extremely convenient programmable menus to name a few.



Fig. 9: KROHNE Compact EMF, flanged version, with IFC 100 (OPTIFLUX 2100C) signal converter

3. EMFs for fully filled pipelines

EMFs feature properties which clearly set them apart from all other flowmeters. This chapter describes the properties of conventional EMFs for fully filled

pipelines. **Fig. 10** and **Fig. 11** contains an overview of KROHNE's comprehensive range of EMF products.



Fig. 10: KROHNE's modular EMF product line, signal converters pictured here

- ① IFC 100 W
- ② IFC 100 C
- ③ IFC 300 R
- ④ IFC 300 W
- ⑤ IFC 300 F
- ⑥ IFC 300 C



Fig. 11: KROHNE's modular EMF product line, primary heads pictured here

- ① **OPTIFLUX 1000**
The economical solution with standard functionality for simple applications
- ② **OPTIFLUX 2000**
The first choice for the water and wastewater industry
- ③ **OPTIFLUX 4000**
The standard solution for the process industry
- ④ **OPTIFLUX 5000 Sandwich**
Maximum chemical resistance, abrasion stability and accuracy thanks to high performance ceramics
- ⑤ **OPTIFLUX 5000 flange**
Maximum chemical resistance, abrasion stability and accuracy thanks to high performance ceramics
- ⑥ **OPTIFLUX 6000**
The device for the food and pharmaceutical industry

3.1. Advantages

It is not without reason that EMFs are the favourite flowmeters in many industries. Electromagnetic flowmeters feature advantages that make them indispensable for many applications. The main advantages include:

- the linear measuring principle;
- the high measuring accuracy;
- the unobstructed cross-sectional area of the tube;
- no mechanically moving parts;
- largely independent of the viscosity and density of the process liquid;
- largely independent of the flow profile;
- measurement in both directions of flow

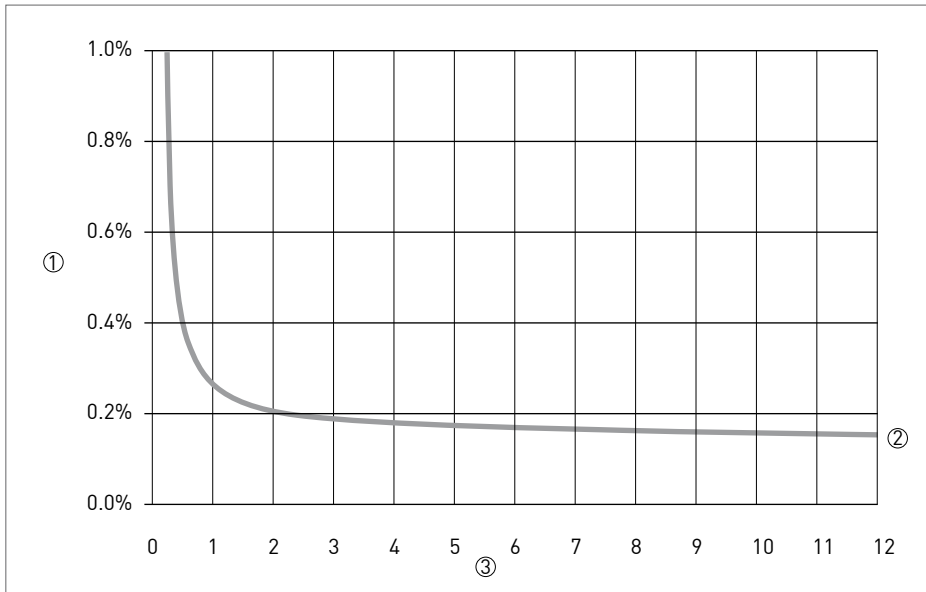

Fig. 12: EMF limits of error at reference conditions (KROHNE, OPTIFLUX 5300)

- ① Measurement error ($\pm\%$ of the measured value)
- ② Limit of error ($\pm 0.15\% + 1 \text{ mm/s}$)
- ③ Flow velocity v [m/s]

Linear measuring principle

The linear relationship between the flow velocity \bar{v} and the signal voltage U allows for linear signal processing. This also enables simple but comprehensive settings of the measuring ranges as well as accurate measurement of pulsating flows.

High measuring accuracy

EMFs generally exhibit minimal measurement error. **Fig. 12** illustrates an example for the specification of error limits under reference conditions.

Because of the accuracy and linear measuring principle used, the latest EMFs can handle measuring ranges of more than 100:1 at measurement errors below 1% of the measured value. In addition, the excellent repeatability is down to 0.03% of the measured value.

Unobstructed tube cross section

The size of the EMF is usually the same as the nominal size of the process piping. The unobstructed tube cross section prevents any additional loss of pressure.

This advantage makes it possible to use them in gravity feed applications, e.g. in wastewater technology, without increasing back pressure. Pump capacity can be reduced in high pressure pipes to save energy. The unobstructed cross section of the EMF tube also makes it possible to measure process liquids with high solids content, e.g. ore or dredging slurries and suspensions, without risk of blockage or abrasion. **Fig. 13** illustrates the unobstructed EMF measuring tube.

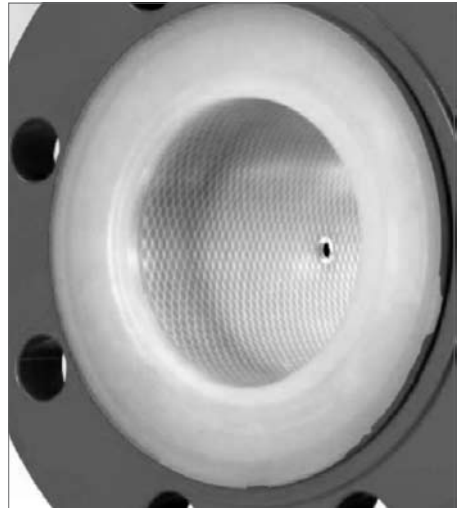

Fig. 13: EMF measuring tube featuring a stainless steel reinforced PFA liner (KROHNE, OPTIFLUX 4000)

Independent of flow profile

When flow changes from turbulent to laminar, minor variations in measurement accuracy may occur, depending on the design of the primary head, see **Section 7.3**.

Independent tests confirm the minimal influence of asymmetrically distorted flow profiles and swirl flow on EMF measuring accuracy, as shown in **Fig. 14**.

When the size of the EMF is the same as the nominal size of the pipeline, a high degree of measuring accuracy can be guaranteed through a straight and unobstructed inlet run, the length of which is about five times the internal diameter of the tube.

This kind of inlet run can lead to installation-related problems in isolation-

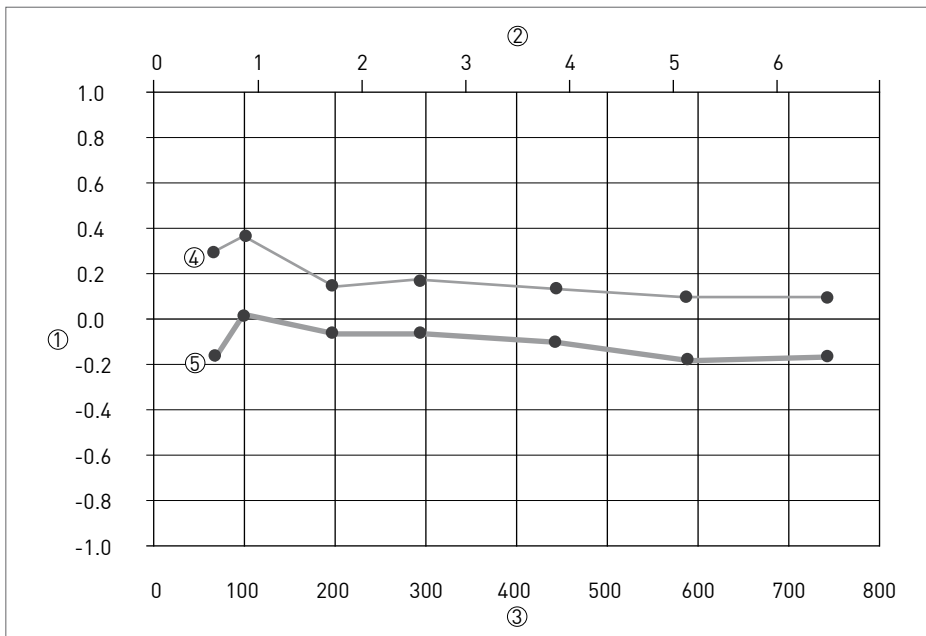

Fig. 14: Effect of the flow profile on EMF measuring accuracy, here using a WIB-SIREP-E-1747-S-94 test with a KROHNE EMF with a nominal size of DN 50

① Measuring error (% of measured value)

- ② Average flow velocity \bar{v} (m/s)
- ③ Flowrate (l/min)
- ④ Swirl, two 90° elbows 5D upstream of EMF
- ⑤ Elbows 5D upstream of EMF electrode position

ed cases, see **Section 8.5**. Problems could arise, for example, if the length of the inlet run for an EMF with a nominal size of DN 1000 was already 5 m. In such cases, the inlet run can be halved by using reducers and an EMF with a smaller nominal size, see **Section 5.2**. However, in so doing, an additional pressure drop, albeit a minimal one, should be taken into account.

No mechanically moving parts

EMFs have no mechanically moving parts. This means that they are practically wear free and robust. For this reason, EMFs have an extremely long service life and are largely maintenance free, even in difficult application areas.

Due to the lack of mechanical components, EMFs have no start-up threshold. Thus, an EMF can measure extremely low flow velocities, close to zero. For certain applications still requiring a start-up threshold, this can be set manually in the signal converter. A start-up threshold may prove useful as a low-flow cut-off to rule out, for example, the effect of thermally induced residual flows on volume flow counting during downtimes.

Independent of viscosity, density and flow profile

EMFs measure the average flow velocity \bar{v} of the process liquid in the pipeline. The velocity depends only on the volume flow rate q and on the inner diameter of the pipe D but not on the physical properties of the process liquid. Due to the minimal influence of the flow profile on the measuring accuracy of the EMF, see **Section 7.3**, the transition from a laminar to turbulent flow profile, for example, caused by a change in the viscosity, causes only minimal measurement error.

Measurement in both flow directions

An EMF can measure with equal accuracy in both directions of flow provided that there are sufficiently long inlets on both sides of the measuring device.

3.2. Limits

In addition to their advantages, these standard EMFs also have limitations, as explained below.

Minimum conductivity of process liquid

Due to the nature of the measuring principle, the process liquid must exhibit a minimum electrical conductivity. Depending on the process liquid, the device version and the measuring application, this is between 0.05 $\mu\text{S}/\text{cm}$ and 50 $\mu\text{S}/\text{cm}$. EMFs are thus not suitable for the measurement of hydrocarbons such as gasoline, oil, etc. and also not for gases. Process measurement problems may occur below the specified minimum conductivity e.g. measuring errors or stable readings. Higher conductivities have no influence on the measuring accuracy.

Completely filling the measuring tube

To measure accurately with conventional EMFs, the measuring tube must be completely full. There are special EMFs for partially filled pipelines, see **Section 4.7**.

3.3. Maintenance

EMFs function without any mechanically moving parts and thus do not wear. EMFs in many applications can work for decades without maintenance. Maintenance work thus primarily involves checking for potential damage that may be caused by external influences, deposits or through abrasion in the measuring tube. For this reason, regular checks should be performed.

Modern EMFs use integrated diagnostic functions to continuously monitor their own functioning as well as process parameters that could negatively affect their function. However, the checks outlined below are still important to guarantee the service life of the device as well as plant reliability.

Checking the flange seals

Leaks in the flange seals can lead to corrosion damage to the flanges or to the process liquid penetrating into the inside of the EMF, causing measurement failure. Faulty flange seals must always be replaced. Observe the manufacturer's recommended tightening torque when reinstalling.

Checking the terminal compartments

Moisture in the terminal compartments of the primary heads and signal converter can result in measuring errors or complete failure. Moist terminal compartments must thus be dried out prior to closing. An electrical test as described in **Section 3.4.** must then be carried out.

Testing the ground connections for corrosion

Ground connections can corrode. The connections at the EMF and the connections of the ground conductors should be regularly tested through to the central grounding electrode.

Checking for vibrations and water hammers

Heavy vibrations and water hammers in the pipeline can occur downstream of positive-displacement pumps or if quick-closing valves are installed. This can cause damage to compact EMFs in particular. During heavy vibration, the pipeline should be supported on both sides of the EMF.

Inspecting the measuring tube for deposits and abrasion

Some process liquids have a tendency to form deposits or incrustations. In such cases, the measuring tube should be regularly cleaned. Cleaning processes and cleaning intervals will depend on the process and on the type of deposit.

Abrasive action increases the inside diameter of the measuring tube. The resultant measurement errors can be corrected by recalibrating the device. If the liner wears thin, an imminent failure of the EMF can be expected. EMFs that have sustained such abrasion damage must be relined by the manufacturer or replaced.

3.4. Testing

The periodic testing of flowmeters is now required and set out by a company's internal regulations (such as ISO 9001: measuring equipment monitoring) as well as legal regulations (e.g. wastewater). The accuracy of flowmeters can be tested in a variety of ways. These include:

- periodic removal of devices for testing on external calibration rigs;
- periodic testing using special external measuring equipment;
- the self-diagnostic function of an EMF, which monitors the accuracy and all process parameters during operation or upon request, eliminating the need for additional testing

3.4.1. Accuracy testing on a calibration rig

The accuracy of an EMF can be tested by the manufacturer or via a flow calibration laboratory. To do this, the EMF must first be removed from the pipeline. This method allows you to check and clean the electrodes and the lining at the same time.

However, this process is labour-, time- and cost-intensive. In addition, removing the device requires an interruption in operation and can only be carried out during plant shutdown.

3.4.2. Testing and documentation with testing equipment

External testing equipment makes it possible to test devices without removing the EMFs from the pipeline. They thus allow statements regarding the functional accuracy of the device to be made with minimal effort.



Fig. 15: EMF test equipment (KROHNE, MagCheck)

The latest generation of external testing equipment uses the device bus to read all of the EMF's set operating parameters and then stores them. A test program then runs automatically to test the electrode resistance, field coil resistance and insulation, the accuracy and linearity of the primary signal processing and

all outputs.

The measured data are first stored in the test control unit. Using KROHNE's MagCheck as seen in Fig. 15, up to 70 records can be collected without battery, storage battery or external power supply connection during the device testing.

Application-specific errors and faults according to VDI / VDE 2650	Possible consequences	Possible causes
Entrained gas in the process liquid	• Measurement error	• Cavitation
	• Unsteady reading	• Negative pressure • Faulty installation
Electrode corrosion	• Unsteady reading	• Incorrect material selection
	• Corrosion • Leakage of the process liquid	• Change in the composition of the process liquid
Conductivity too low	• Reading too low	• Process liquid has changed
	• Unsteady reading	• Incorrect choice of measuring device
Liner damage	• a small % measurement error to complete	• Incorrect material selection
	• Destruction of the EMF	• Abrasion caused by solids
	• Leakage of the process liquid	• High temperature and vacuum
		• Faulty installation
Deposits on electrodes	• Measurement error	• Depositing of oils and grease on the electrodes
	• Unsteady reading	• Electrode passivation due to incorrect material selection
	• Measurement failure	
External magnetic fields	• Measurement error	• Electric furnaces
	• Fluctuating reading	• Electrolysis plants
Electrode short circuit	• Reading approaches zero	• Metallic deposits in measuring tube
Partial filling	• Measurement error	• Faulty installation
	• Fluctuating reading	

Table 1: Diagnostic requirements for EMFs as per VDI / VDE 2650, Sheet 3

This data is then subsequently downloaded to a PC. Using the PC software included with delivery, these measurement results are evaluated in relation to specified limit values and compared to the current setting data in relation to the measuring results of the last test. Based on this information, the software generates trend analyses of all data for each measuring station and advises when changes are too large. If the changes are within the tolerance range, a test certificate is issued, certifying that the EMF exhibits a measurement error of less than 1% compared to the initial

calibration in terms of its electrical and electronic function.

3.4.3. Intelligent self-diagnostics

In order to avoid any interruption in operation to perform checks, users and manufacturers formed a joint NAMUR working group to compile the most frequent error modes in the VDI/VDE 2650 directive. They are listed in **Table 1** (see previous page).

The IFC 300 by KROHNE complies with and exceeds this directive. It achieves this by using diagnostic tools that go above and beyond the requirements. For

Application-specific errors and faults	Possible consequences	Possible causes
Inaccuracy of signal processing	<ul style="list-style-type: none"> • Measurement error 	<ul style="list-style-type: none"> • Component drift
Coil temperature too high	<ul style="list-style-type: none"> • Reduced service life 	<ul style="list-style-type: none"> • Process liquid temperature too
Electronics temperature too high	<ul style="list-style-type: none"> • Reduced service life 	<ul style="list-style-type: none"> • High process liquid temperature not permitted
	<ul style="list-style-type: none"> • High probability of failure 	<ul style="list-style-type: none"> • Solar radiation
	<ul style="list-style-type: none"> • Drift, measurement 	<ul style="list-style-type: none"> • Faulty components
Non-linearity of magnetic circuit and Signal processing	<ul style="list-style-type: none"> • Measurement error 	<ul style="list-style-type: none"> • External magnetic fields
		<ul style="list-style-type: none"> • Fault with electronics
Faulty field current value	<ul style="list-style-type: none"> • Measurement error 	<ul style="list-style-type: none"> • Fault with electronics
		<ul style="list-style-type: none"> • Coil interruption
Faulty current output	<ul style="list-style-type: none"> • Measurement error 	<ul style="list-style-type: none"> • Load too high
		<ul style="list-style-type: none"> • Interruption
Flow profile	<ul style="list-style-type: none"> • Measurement error 	<ul style="list-style-type: none"> • Installation, e.g. downstream of valve
	<ul style="list-style-type: none"> • Measurement failure 	

Table 2: KROHNE's IFC 300 diagnostic tools which exceed VDI / VDE 2650 requirements

examples of these tools, please refer to Table 2.

Self-diagnostic functions via the measuring electrodes

During self-diagnostics, the signal converter induces an alternating current I_{EP} into the process liquid via the electrodes. This current creates a drop in voltage U_{RE} , which is dependent on the resistance R_E , in other words the electrical conductivity σ of the process liquid, see Fig. 16.

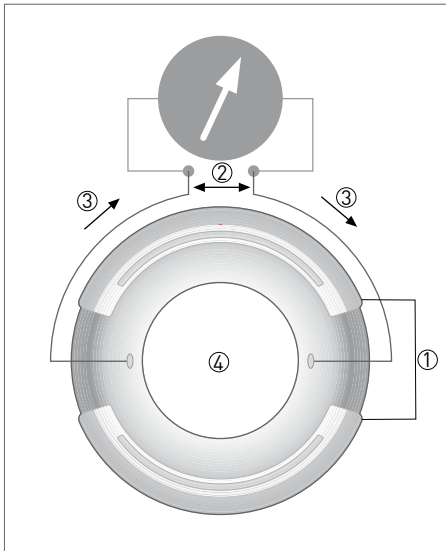

Fig. 16: Monitoring of general error modes using the measuring electrodes

- ① Coil
- ② $U_{RE} = (R_E, \sigma)$
- ③ I_{EP}
- ④ $R_{EI} = f(\sigma)$

The following error modes can be obtained:

- Electrode contamination;
- Short circuit or interruption in the electrode connection cable (important in "remote version" EMFs).

The measured resistance R_{EI} enables the indication of the conductivity σ with the following statements:

- conductivity outside of permissible limit of EMF or process liquid;
- Quality of cleaning processes (e.g. wastewater);
- Change in process liquid (e.g. transition from process to cleaning liquid or vice versa with CIP processes).

The status outputs with their adjustable switching points or bus connections signal that the preset conductivity switching point has been exceeded or not attained.

Testing the flow profile

Another diagnostic option which can be used to discover potential error sources is to measure and evaluate the flow profile in the measuring tube.

Fig. 17 illustrates how deposits in the EMF, for example, can lead to incorrect measurement results.

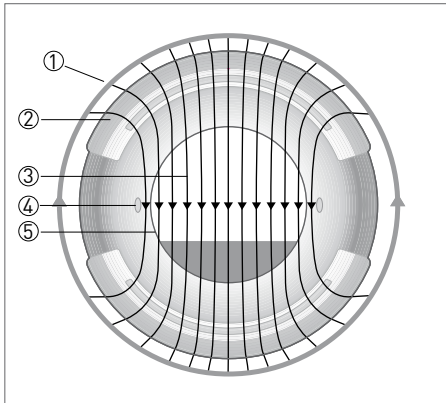

Fig. 17: Magnetic field with normal field coil polarity for flow measurement

- ① Ferromagnetic yoke
- ② Field coils
- ③ Magnetic field with induction B
- ④ Measuring electrode
- ⑤ Measuring tube

A flow-dependent voltage is induced in a flowing process liquid. In coatings where $v = 0$ the voltage is zero. The sum of these two voltage parts at the electrode gives a faulty reading of the flow.

With flow profile measurement, reliable statements can be made about a variety of states and errors during measurement:

- Partly filled measuring tube;
- deposits at the bottom of the measuring tube;
- faulty liner;
- Poor installation, e.g. a gasket protrudes into the measuring tube or the inlet/outlet runs are not sufficiently long.

The symmetry of the flow profile is tested by reversing the polarity of the upper and lower field coils, as illustrated in Fig. 18.

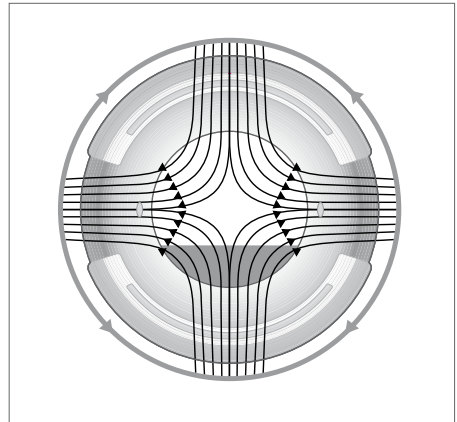

Fig. 18: Measuring the flow profile by reversing the polarity of the upper and lower field coils

This means that flow-dependent voltages with opposite polarities are induced in the upper and lower half of the measuring tube.

In the case of an undisturbed symmetrical flow profile, the flow values in the upper and lower halves of the measuring tube are the same. This means that the induced voltages both above and below are of the same size. Due to the reversal in polarity of the magnetic field, they have opposite polarities and add up to zero at the electrodes.

With a disturbed flow profile, however, the values of the signal voltages at both electrodes are not the same. The signal converter can determine the degree of the disruption of the flow profile and the thickness of the coating from the difference between the signal voltages.

For more details on flow profiles, refer to **Section 8.5**.

4. EMFs in special areas of application

This chapter introduces additional device versions for special areas of application for electromagnetic flowmeters.

Fig. 19 shows a small selection of special solutions that KROHNE can provide in these cases.



Fig. 19: KROHNE specialists for special applications

① **OPTIFLUX 4040**

A 2-wire device

② **OPTIFLUX 7080 FLANGE**

For the highest requirements using capacitive electrodes and ceramic measuring tubes

③ **CAPAFLUX 5080 SANDWICH**

For the highest requirements using capacitive electrodes and ceramic measuring tubes

④ **TIDAFLUX 4110 PF**

For partially filled pipelines

⑤ **BATCHFLUX/BATCHCONTROL**

For volumetric filling systems in the beverage industry using CANopen-Bus

⑥ **WATERFLUX**

For remote measuring stations with no power supply

EMF properties are so universal that these measuring devices are often used as the basis for solving very specific problems in flow measurement.

Often, all that is necessary to find the answer to a difficult question is a certain amount of application experience, commitment on the part of the EMF manufacturer and a reliable EMF. In other cases, properties are required that vary so widely from any standards that a completely new development is necessary. Both cases can be seen in the following examples.

4.1. Explosion protected versions

Explosion protection is generally a safety topic and is thus subject to many legal and technical rules. For this reason, there will be no detailed handling of explosion protection in industrial measuring devices here. The aim here is rather to illustrate the background to the topic of explosion protection.

For more detailed information, please refer to technical regulations and information provided by the device and component manufacturer.

Risk of explosion and hazardous area

In the chemical and petrochemical industry, in crude oil and natural gas exploration and in many other industries, gases and vapours may escape under certain circumstances during the production and processing as well as the transport and storage of flammable substances. Many production processes e.g. in the food industry or in mining, may produce flammable dust. These flammable gases, vapours, and dust can form a hazardous atmosphere when combined with the oxygen in the air. In such cases, there is a risk of explosion. The area

in which such risks occur is known as an "Ex-area".

To cause an explosion, an effective ignition source must be available. Sometimes all it takes is a small spark or a surface that is too hot.

Preconditions for an explosion

In order for a fire or explosion to take place, three conditions must be in place at the same time. They are: a flammable material, a source of oxygen and potential ignition sources that could trigger an explosion or fire. With the help of the examples given in **Table 3**, it is easy to determine when or if these preconditions are present in a plant or not.

Explosion protection

The explosion protection contains precautionary measures to avoid explosions

and the resulting dangers to life and health. The requirements for operational explosion protection are regulated by the European directive 1999/92/EC (ATEX 137, formerly ATEX 118 a) and in Germany by the Ordinance on Industrial Safety and Health (BetrSichV). From 1 July 2003 only equipment (devices, components) that complies with EC directive 94/9/EC (ATEX 95, previously ATEX 100a) may be used in hazardous areas.

This directive regulates the design and testing of explosion-protected systems, devices and components. It applies in the CENELEC (countries in the European Community and the EFTA). Unlike previous explosion protection directives and ordinances, ATEX for the first time includes mechanical devices and components.

Preconditions for an explosion:	Examples
Ignition sources	Hot surfaces, open flames, electric sparks, mechanical friction and impact sparks, electromagnetic radiation, electrostatic discharges, etc.
Oxygen sources	Air, pure oxygen, chemical compounds giving off oxygen
Flammable substances	Gases, vapours, mist, dusts that come from flammable liquids or solids and are present in the right concentration for ignition

Table 3: Preconditions for an explosion

Laws, ordinances and standards

A wide variety of groups and institutions are involved with "explosion protection" – from lawmakers to standards committees, testing and approval bodies, monitoring, accident prevention and supervisory organisations to trade unions, insurance providers, manufacturers, installers and plant operators.

For more information about standards dealing with explosion protection, go to:

www.explosionsschutz.ptb.de
www.newapproach.org

In countries outside of the CENELEC area, other standards and regulations are in place. For example, the USA, Canada, China, Japan, Australia, CIS, Hungary, Brazil and South Africa require their own national approvals.

Equipment categories in hazardous areas (excluding mines)

All equipment, including measuring devices, is divided into three categories depending on the degree of safety for areas with explosion hazards arising from gas and dust, see **Table 4**.

Gas	Dust	Required level of safety
II 1G	II 1D	Very high
II 2G	II 2D	High
II 3G	II 3D	Normal

Table 4: Equipment categories for gas and dust atmospheres

Measuring devices which fall under equipment category 1 or 2 must first be approved by a recognised testing body. In accordance with ISO 9001:2000, companies that manufacture equipment or components for these devices must possess a special QA certification in compliance with the 94/9/EC directive. Only then may they display the CE marking on the data plate.

Installation in hazardous areas

EMFs must be installed in accordance with the Ex instructions of the equipment manufacturer. These Ex instructions make up part of the Ex approval. An EMF may only be used in the operational conditions that fall within the limits of the information given, e.g. range of application, equipment category, temperature class and any additional conditions.

Non-compliance with the information contained in the installation guidelines results in termination of the approval for the measuring device installed.

Operation in hazardous areas

Areas in which a hazardous, potentially explosive atmosphere may occur are divided into zones depending on the probability of the occurrence of this explosive atmosphere, as shown in **Table 5**.

Atmospheres with explosion hazards arising from gas are classified as Zone 0, Zone 1 and Zone 2. Atmospheres with explosion hazards arising from dust fall into Zone 20, Zone 21 and Zone 22.

In accordance with the BetrSichV [Ordinance on Industrial Safety and Health], the operator of the plant is solely responsible for the safe operation of the plant. He must

Gas	Dust	Danger
Zone 0	Zone 20	Constant
Zone 1	Zone 21	Occasional
Zone 2	Zone 22	Rare

Table 5: Classification of hazardous operating areas

determine which areas are hazardous and select the equipment suitable for use in this area. The operator alone undertakes to meet all organisational and technical measures to protect against explosion and in particular to carry out or have carried out the required testing in a timely manner. In addition, all equipment in hazardous areas that may contain an ignition source must be marked as such in accordance with directive 94/9/EC (ATEX). The plant operator must then issue an explosion protection document.

4.2. EMFs for custody transfer

There is an obligation to have measuring devices and systems officially calibrated if that equipment is used to measure quantities commercially between independent partners and where the result of the reading affects the amount of an invoice.

The legal basis for these devices is the "Directive 2004/22/EC of the European Parliament and the Council of 31st March 2004", also known as the "Measuring Instruments Directive" (MID). This directive supersedes any previous, national and EEC directives. It regulates the requirements that the device under test must comply with during the type certification test, from the manufacturer and from the notified bodies. Approvals based on older directives expire on 29.03.2016 at the latest. In the area of liquid flow measurement, the directive applies to the following devices or systems:

- Water meter (Appendix MI-001);
- Heat meter (Appendix MI-004);
- Measuring systems for the continuous and dynamic measurement of quantities of liquids other than water (Appendix MI-005).

EMFs can be used, for example, as water meters, or as a component of heat meters or measuring systems for all quantities of liquids other than water. If the EMF measurement results are used for billing purposes, the EMFs are subject to mandatory calibration. In other words, they must be officially calibrated by a notified body.

The prerequisite for this official calibration is previous approval of the device design type for custody transfer. This approval for custody transfer consists of a type examination, also known as conformity assessment. The conformity assessment is a test of how the device, its accompanying documentation and the manufacturer's QA system conform to the requirements of EU Directive 2004/22/EC of 31 March 2004. The conformity assessment is performed by an accredited body (e.g. the National Metrology Institute) on a sample device and the accompanying documents. This approval describes or limits the range of application, as well as the conditions of use and installation. Here, for example, a longer unobstructed inlet run can be prescribed for use in custody transfer.

Once the test has been successfully completed, the approval for custody transfer is granted for the approved design. An EMF may not be calibrated without this approval for custody transfer.

The first, easily recognisable sign that a device has been calibrated is the CE and metrology markings, as pictured in Fig. 20.

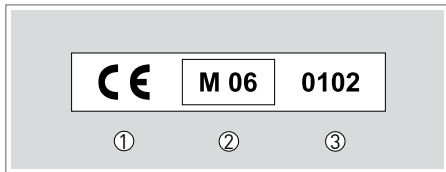

Fig. 20: XY metrology marking

- ① CE marking
- ② Metrology marking
- ③ Number of notified body

4.3. EMFs in environments with strong magnetic fields

EMFs can also be used, for example, in the vicinity of electrode feeder lines for electric furnaces and in electrolysis plants in which current strengths well in excess of 10 kA generate strong magnetic fields. The flow indication of an EMF can be affected by strong dc or ac field currents.

Strong dc fields

If the external magnetic field is caused by very strong direct currents, such as in electrolysis plants, the following may occur.

EMFs have a ferromagnetic magnetic field feedback circuit. This return circuit affects the field strength of the magnetic field generated by the EMF field coils. If the external interference field has a strong effect on the magnetic circuit of the EMF, its magnetic resistance increases. The magnetic field strength B and the signal voltage U of the EMF become weaker. This can result in large measurement errors.

In principle, this effect can also occur when magnetic fields are generated by alternating current. But in this case this would only happen if the currents were much higher.

Strong external alternating fields

With external magnetic fields generated by strong alternating currents, in alternating current furnaces for example, a further effect can be seen.

These magnetic fields can induce such high currents in the pipelines in the vicinity of the transformers or the electrode feeders for the furnace, that ground conductors and ground connections from the EMF to the pipeline can melt. The pipelines and grounding connections function like secondary windings of a transformer. The currents induced therein and the coupled voltages are transferred via the process liquid to the EMF electrodes and can noticeably disrupt measurement.

Effects of strong magnetic field fluctuations

Both effects (interference with the magnetic circuit and induced currents and voltages) can be superimposed on one another. For example, the direct current

of an electrolysis plant still has a ripple that is expressed as an alternating current component. In the case of electric arc furnaces, additional disruptions may occur if the electrodes short circuit via the melted goods or the electric arc is interrupted. As a result, current fluctuations of a few kA can be caused which in turn induce currents and voltages which can then cause interference.

The suitability of the EMF for this application thus depends on the manufacturer and the type. The prerequisite for smooth functioning is first and foremost the correct choice of EMF type. To make the correct choice, a variety of information is required in the planning stages. This includes the nominal size, type of pipeline, strength of the magnetic field at the installation site of the EMF and the distance to the cables carrying the current and their current strength, as well as the type of current (direct, alternating or three-phase), etc., see **Section 5**.

4.4. Measuring pulsating flows using EMFs

There are only a few flowmeters that can measure pulsating flows without pulsation dampeners being installed directly downstream of the positive-displacement pump. KROHNE EMFs are always able to measure pulsating flows.

Fig. 21 illustrates the digitised flow values when measuring pulsating flows on the internal device bus in a KROHNE signal converter after the first digital filter.

Pulsating flow can be recognised by peak values which can be more than 3 times higher than the average flowrate. For precise measurement, the peak

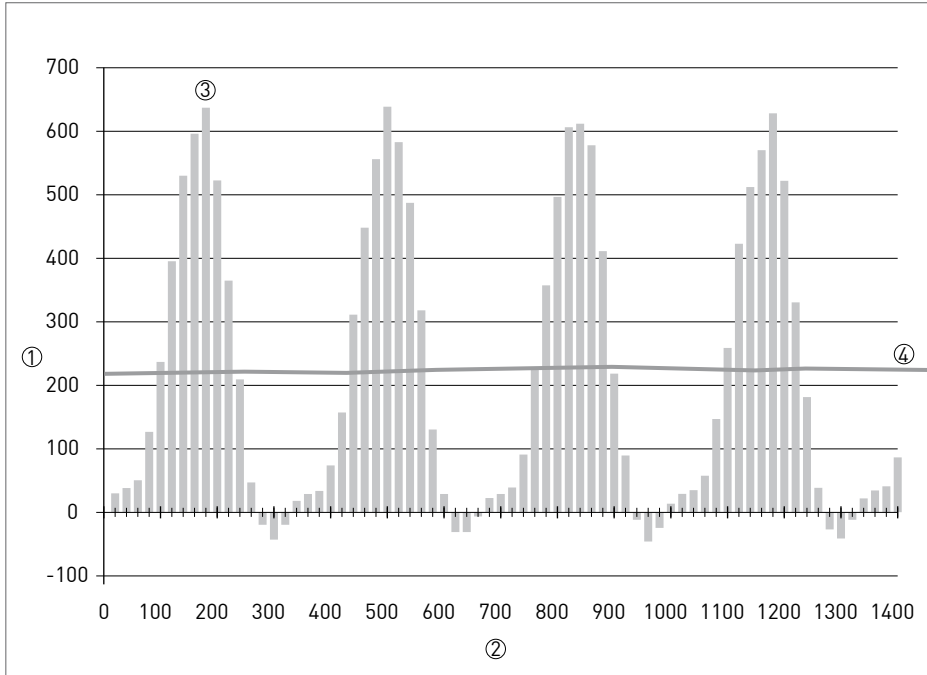

Fig. 21: Example of the measurement of pulsating flow, pictured here at the outlet of a diaphragm pump

- ① q [l/h]
- ② t [ms]
- ③ $q [t]$ [l/h]
- ④ $q_i [t]$ [l/h] $T = 10s$

values must be processed quickly and accurately in a linear manner without saturation and overmodulation. The sampling frequency, i.e. the number of sampling pulses from the signal converter per time unit, must be at least 10 times higher than the highest occurring pulsation frequency.

The time constant of the signal converter must be set sufficiently high enough to average the pulsating flow sufficiently and achieve a steady reading. The suitability of the EMF for this application thus depends on the manufacturer and the type. For this reason, users should be well informed and seek advice before selecting a device.

With pulsating flows, manufacturers generally have special setting regulations which must be taken into account. Strong vibrations may occur in the vicinity of positive-displacement pumps. KROHNE thus recommends the use of remote version electronics for the EMFs. The signal converter must be firmly mounted to a vibration-free support. For compact EMFs, the pipeline must be supported on both sides.

4.5. EMFs for products with high solids content

EMFs have been successfully used in hydraulic transport for approx. 50 years. Due to the number of variables that apply here, it is not possible to deal extensively with the topic of "hydraulic transport" at this time. This chapter is therefore limited to a few practical examples and tips to be used in practice.

The completely unobstructed cross-sectional tube area and the measuring principle that determines the full volumetric flow, including solids, make it possible for EMFs to measure liquids with a high solids content. For this reason, EMFs are frequently combined with radiometric density meters to determine mass flow. This combination also monitors the mass flow at a sufficiently high flow velocity and to ensure the maximum permissible concentration of solids in order to prevent blockages in the pipeline.

Below are a few examples of application areas and process liquids:

Use on dredging vessels

The task of an EMF when used on a dredging vessel is to record the measurement and to control the height of the suction pipe above ground for optimum capacity.

The transport medium in this case is sea water. Solids generally include sand, gravel and large rocks. The solids content can reach 50% by weight for flow velocities of up to more than 10 m/s. When used in this application, EMFs usually have a nominal size of approx. 300 mm to 1400 mm and usually feature thick polyurethane or ceramic liners.

Coal mining

Here, EMFs are used in the coal wash, in other words, when separating the coal and the rocks. The medium here is then water with coal and rocks.

In individual cases, EMFs have been used to transport the coal/rock mixture hydraulically out of the mine from the bottom to the surface in order to measure production quantities (at transport distances of approx. 1000 m from the bottom to the surface).

Ore mining

From gold mines to copper mines, EMFs measure the hydraulically transported quantities of ore and rock on their way from the conveyor point to the ore processing plant. For this reason, EMFs with a soft rubber liner are often used.

When it comes to the chemical processes involved in treating the ore, EMFs measure acids and other reagents used to separate the metal from the rock.

Aluminium industry

Here, EMFs are used for measurements in all process stages in which liquid media are found, even those with high solids content e.g. abrasive bauxite slurry at temperatures up to 140°C.

Pulp and paper industry

In this industry, EMFs measure, for example, the flow of wood pulp or dissolved recovered paper in the de-inking industry as well as highly abrasive tailings. Solids content of 15% downstream of the refiners pose no problem for EMFs with pulsed dc fields. The quantities are measured and controlled by EMFs,

right down to the head box on the paper machine. EMFs can also be used at other stages, e.g. during bleaching or colouring. Extremely fine solid suspensions with TiO_2 and other fillers and coatings are required to give the paper a fine, smooth surface. The mixture of these suspensions is also controlled using EMFs.

Cement

The supports on oil drilling platforms, for example, are partially filled with cement to prevent the platform from floating up. EMFs measure the compressed quantity of cement to ensure that the right amount is filled.

Special requirements for EMFs in hydraulic transport

Solid particles can often be abrasive. The wetted materials and the liner must thus be abrasion-resistant. For help in selecting the right device, see **Table 9** in **Section 5.2**. High pressure is also present in many applications, which further limits selection.

Selecting an EMF for applications in hydraulic transport

These examples illustrate how varied the requirements that are placed on EMFs are when it comes to the respective measuring tasks in hydraulic transport.

The following points are important when selecting the EMF and its materials for this application:

- Solids content (in per cent by weight or volume);
- Size, density, hardness and shape of the solid particles;
- Flow velocity;
- Installation position (horizontal, vertical or at a slope);
- Temperature, pressure of the process liquid;
- Effects on flow profile, e.g. elbows in front of the EMF.

This information will help in the selection of suitable materials.

Installation guidelines for EMFs in hydraulic transport

The topic of abrasion is a top priority when it comes to products with high solids content. EMF abrasion depends on the properties of the solid as well

as on the operating conditions and the installation position.

In horizontally positioned pipelines, some of the solid particles always rub along the bottom of the tube, which can lead to abrasion.

Centrifugal forces act on the solid particles when there is a change in direction, for example, as a result of elbows in the pipe. The coarser particles are then pushed outwards and rub against the walls of the tube for long stretches.

In this instance, high demands are placed on the EMF liner and the EMF should be installed at least 10xDN downstream of an elbow.

Edges that protrude into the flow are also subject to intense abrasion. These edges could be the result of different pipe diameters or unevenly matched pipelines, as shown in Fig. 22. This situation is especially critical in the case of conventional EMFs featuring plastic liners as they usually have a somewhat smaller diameter than standard pipelines. In this case, there are two possible options.

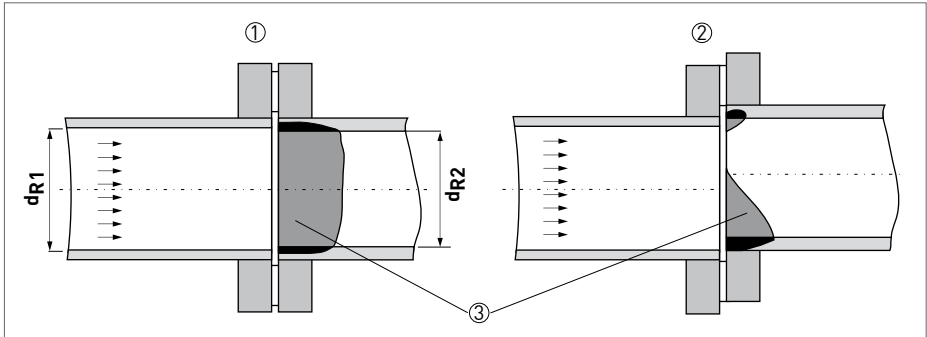

Fig. 22: Wear on pipe connections during hydraulic transport and edges protruding into the pipeline

- ① Wear in the case of varying pipe diameters ($d_{R2} < d_{R1}$)
- ② Wear in the case of unevenly matched pipelines
- ③ Zones attacked by abrasion

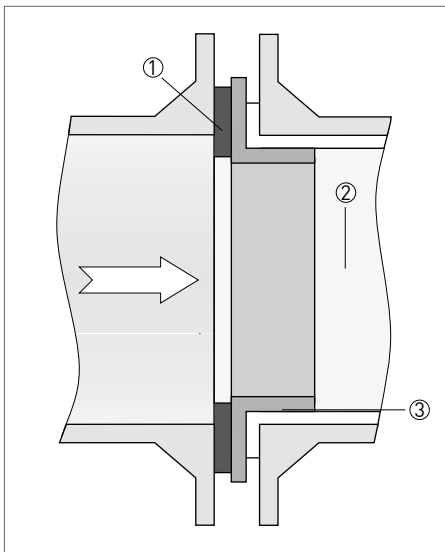

Fig. 23: Protective ring to protect the liner of the EMF during hydraulic transport

- ① Gasket
- ② EMF liner
- ③ Protective ring

The most common solution is to install a protective ring on the edge of the inlet side of the EMF as depicted in Fig. 23.

A different and more elaborate solution is to match the inside diameter of the pipeline to that of the EMF. Depending on the nominal size and liner material, the inside diameter of the EMF can be adapted closely enough to result in a step-free transition.

Flow profiles in products with high solids content

When the density of the solid is higher than that of the carrier liquid, the solid tends to sink. The speed at which the particle sinks depends on the difference in density as well as the shape and size of the particle.

In a horizontal pipeline, the solids sink towards the bottom of the pipe. The flow keeps the particles in motion. The speed of the particles is slower at the bottom of the pipe, resulting in an increase in concentration of solids towards the bottom of the tube, as shown in Fig. 24.

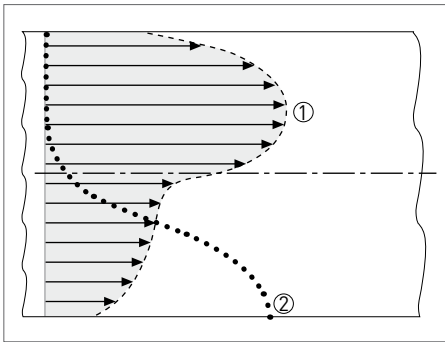

Fig. 24: Flow and concentration profile when hydraulically transported in a horizontal pipeline

- ① c : Concentration of solids
- ② v : Flow velocity

The result is distortion of the normal symmetrical flow profile. When the flow is low, the solids settle on the bottom. The unobstructed cross-sectional area above the layer of deposits then becomes smaller. This happens until the flow velocity increases enough for all of the other particles above the layer of deposits to

stay in motion. This kind of distorted flow profile does not, however, noticeably affect the measuring accuracy of the EMF and rarely becomes a problem in practice.

When the pipeline is in a vertical position, the behaviour is different, see Fig. 25. When the flow velocity is relatively low, a constant flow in which the solids are evenly distributed develops, as shown in Fig. 25 on the left. However, when the flow velocity is high and the inlet run is sufficiently long and unobstructed, the solid particles concentrate more in the middle of the pipe. This results in the carrier medium flowing around the "solids column" in a circular pattern towards the top. Fig. 25 on the right illustrates just such a flow. The dark core in the middle marks the flow velocity of the solids, whereas the light area represents the flow profile of the carrier liquid in the ring between the solids column and the wall of the pipe.

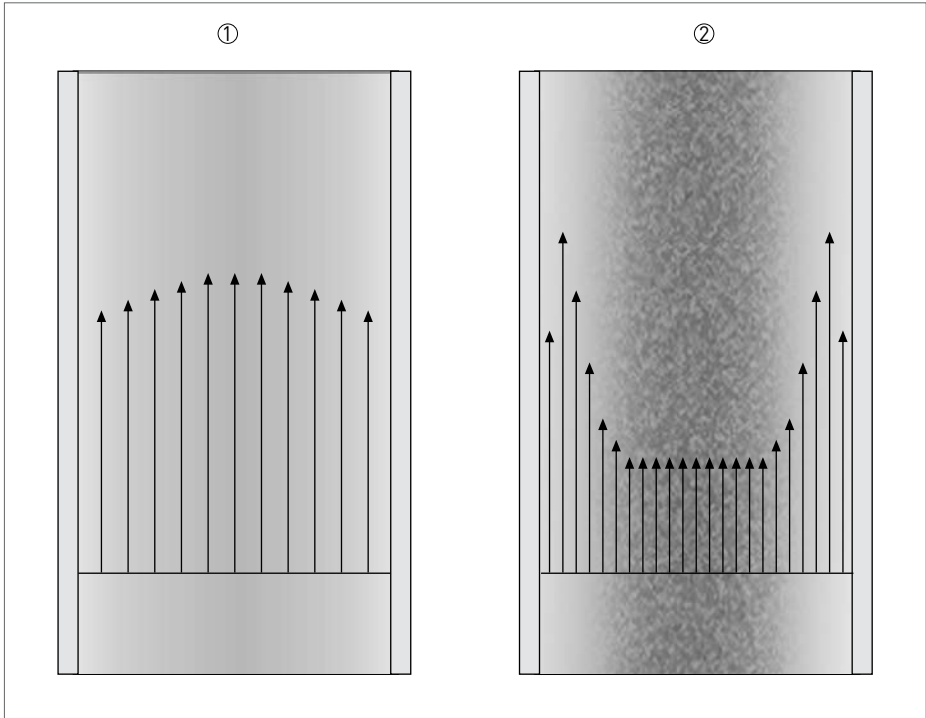

Fig. 25: Flow patterns during hydraulic transport in long, perpendicular pipelines

- ① Flow profile at low flow velocity
- ② Flow profile at high flow velocity

Extremely high flow velocities can occur in the ring between the solids column and the wall of the pipe. This results in a flow profile featuring a slow solids column in the middle of the pipe (e.g. $v_s = 5 \text{ m/s}$) and a much faster ring of the carrier liquid (e.g. $v_f \geq 15 \text{ m/s}$). In this case, only the shear stress between the liquid and the solids column is used to

transport the product. Increasing the flow velocity does not further increase the solids transport.

EMFs register higher flow velocity in the vicinity of the electrodes, which means that such extremely distorted flow profiles result in a flow value indication that is too high.

It makes, therefore, more sense to install the EMF in a horizontal section of the pipeline or at a distance of 10xDN downstream from an elbow where a solids suspension is not yet completely separated.

EMFs have also been successful in extremely harsh applications in hydraulic transport. To ensure smooth functioning and a long service life, a detailed discussion with the EMF supplier is necessary.

It is also extremely important to use tried and tested solutions and materials, even if at first glance there are other alternatives that may seem to be more cost-effective.

4.6. EMFs without electrodes with capacitive signal pick-up

For process liquids with extremely low electrical conductivity and for those that form insulating deposits on the wall of the tube, interrupting the contact between the process liquid and the electrode, there is an EMF featuring non-contacting capacitive signal pick-up.

Fig. 26 shows the structure of an EMF with capacitive signal pick-up.

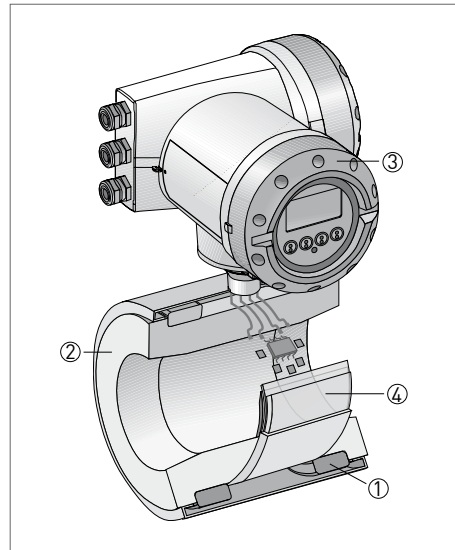

Fig. 26: Structure of an EMF with capacitive signal pick-up

- ① Field coils
- ② Measuring tube
- ③ Signal converter
- ④ Capacitive electrodes

With these EMFs, the electrodes are attached as large area condenser plates to the outside of the liner or to the non-conducting measuring tube. The signal voltage from the process liquid is capacitively picked up and without contact to the liquid. These signals pick-ups and the associated projecting surfaces are fused-in-place to the outside of the ceramic measuring tube by using methods in microsystem technology. This ensures that vibrations and impacts cannot cause any interference voltages through piezoelectric effects and that the EMF display remains steady.

EMFs with capacitive signal pick-up offer a variety of advantages compared to conventional EMFs with classic electrodes in contact with the product.

Thus, a minimum conductivity of just $0.05 \mu\text{S}/\text{cm}$ is sufficient for measurement. However, for conductivities less than $0.3 \mu\text{S}/\text{cm}$, consult the EMF manufacturer prior to selecting a device as some products prove to be completely non-conductive in the actual process even if they show a laboratory value of, e.g., $0.2 \mu\text{S}/\text{cm}$.

EMFs with capacitive signal pick-up provides outstanding performance with products that deposit insulating layers on the walls of the pipe e.g. latex or bitumen suspensions. These layers can insulate the electrodes of conventional EMFs, resulting in measurement failure. With capacitive EMFs, such thin layers do not lead to failure. Instead, the layers have only a minimal influence on measuring accuracy.

The flow indicator of a capacitive EMF is steadier than that of the classic EMF with inhomogeneous products. This applies, for example, to products containing a high degree of solids content, products that have been poorly mixed or that exhibit as yet incomplete chemical reactions, e.g. downstream from a neutralising point. The capacitive signal pick-ups integrate spatial interferences across their large electrode area.

With conventional EMFs it is possible that there is no electrode material that is compatible with all of the various process liquids that flow through a pipeline. With capacitive EMFs, on the other hand, it is enough that the material of the pipe is compatible.

EMFs featuring non-wetted, capacitive signal pick-up have proven successful in practice and are well suited to process liquids

- with low electrical conductivity;
- for which it is either difficult or impossible to select metallic electrodes;
- which lead to insulating deposits in the measuring tube and on the electrodes, e.g. latex or bitumen suspensions;
- with a high degree of solids content;
- with intense fluctuations in terms of chemical properties, e.g. poor mixing or as yet incomplete chemical reactions (neutralisation).

EMFs with capacitive signal pick-up offer a variety of advantages in practice.

4.7. EMFs for partially filled pipelines

The pipelines in sewage and wastewater systems are generally not completely filled, so classic EMFs had to be installed in a so-called sluice underpass to ensure that the pipeline was completely full. That cost money and required periodic cleaning to avoid blockages. With the introduction of EMFs for partially filled pipelines, such problems are a thing of the past, see Fig. 27.



Fig. 27: KROHNE TIDALFLUX 4110PF, the world's first EMF for partially filled pipelines featuring non-wetted level measurement

The design of such EMFs is very similar to that of EMFs for fully filled pipelines. However, EMFs for partially filled pipelines have at least one additional, electrode pair mounted near the bottom. This makes it possible to measure

the signal voltage U and thus the flow velocity \bar{v} even when the level in the pipeline is very low. In addition, these KROHNE EMFs feature patented capacitive level sensors embedded into the wall of the tube. This setup allows the filling height h to be measured in the measuring tube itself. Based on the filling height, the flow cross section A can be calculated because the diameter of the

tube is known. Using the average flow velocity \bar{v} and the flow cross section A , the volume flow q can be calculated:

$$(7) \quad q = \bar{v} \cdot A$$

Fig. 28 illustrates once again the measuring principle of EMFs for partially filled pipelines.

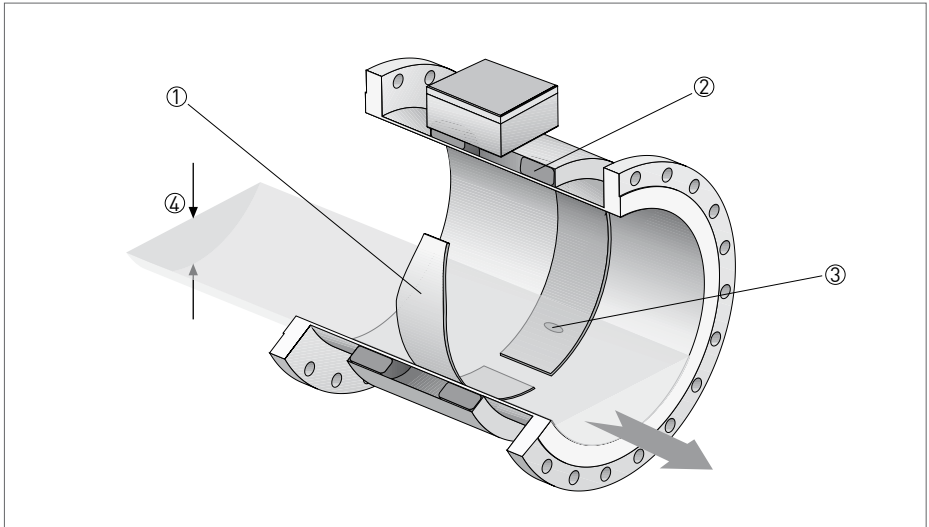

Fig. 28: Measuring principle of an electromagnetic flowmeter for partially filled pipelines (KROHNE, TIDALFLUX 4110PF)

- ① Capacitive, non-wetted level measurement (embedded in the liner)
- ② Field coil
- ③ Measuring electrodes
- ④ Filling height h

Prior to using an EMF for partially filled pipelines, note that these EMFs start measuring only when the minimum filling level has been reached. This level generally corresponds to 10% of the tube diameter. The minimum flowrate at which measurement begins depends on the pipe gradient and roughness of the pipeline wall but is typically approx. 2.5% of the flowrate in a fully filled measuring tube.

The inflow conditions for EMFs for partially filled pipelines in open channels are much more difficult to control than in fully filled pipelines. This is mainly because the exposed surface of the flow, depending on the kind of disturbance, becomes calm only after very long stretches. In such cases, the user should seek advice from the appropriate manufacturer.

4.8. Battery-operated EMFs for remote measuring points

In many drinking water, untreated water and tap water systems, as well as in agricultural irrigation systems, water meters are installed in lines located in remote measuring points. There is often no available power supply in these areas and the meter must work without power.

Mechanical water meters have always been used in such situations. However, their measuring accuracy frequently suffered due to incrustations occurring with the use of hard water as well as contamination from untreated water. The use of filters makes these measuring points expensive and maintenance intensive.

While EMFs are not plagued with these disadvantages, they do require a power supply. Vandalism and theft made the use of solar panels impractical. In battery mode, the high power demand of conventional EMFs reduces long battery life.

The WATERFLUX 3070 EMF was developed by KROHNE as a battery-operated electromagnetic water meter

for standard applications in the water and wastewater industry, see Fig. 29.



Fig. 29: KROHNE WATERFLUX 3070C

The WATERFLUX 3070 is thus superior to mechanical water meters, mainly because of its measuring principle without any moving parts. No moving parts means that there is no rubbing, wear or blockages caused by dirt and incrustations. The surface of the lining is smooth and largely corrosion resistant, thus reducing the tendency towards deposits. This results in excellent long-term stability.

The WATERFLUX 3070 boasts significant cost advantages when it comes to

measuring points with large nominal sizes. Any additional costs for spare filters, flow straighteners as well as maintenance and cleaning work are eliminated.

The key feature of the WATERFLUX 3070 is its measuring tube. The tube design and material contribute significantly to both the function and accuracy of the WATERFLUX 3070. The shape of the measuring cross sectional area was designed in such a way that the electrode distance D was larger than the height of the measuring tube, i.e. a smaller distance between the coils. The result is the almost rectangular measuring cross section shown in Fig. 30. The rectangular shape of the measuring tube has a positive effect on the measuring accuracy and the battery life.

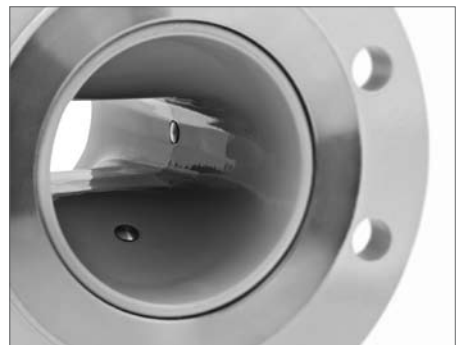

Fig. 30: WATERFLUX 3070C measuring tube

When investigating the influence of the flow profile, J. A. Shercliff discovered the valence function for circular cross sections, see **Section 8.2**. He also demonstrated that the accuracy of EMFs with a rectangular measuring tube cross section, homogeneous magnetic field and surface electrodes are barely affected, even with a distorted flow profile. That means that the WATERFLUX 3070 requires only short inlet and outlet runs and can be installed in very narrow standpipes and shafts.

The minimal height of the measuring tube decreases the distance between the field coils, thereby increasing the field strength **B** of the magnetic field. In addition, the flow velocity \bar{v} increases significantly due to the rectangular reducer.

Note:

The following applies to signal voltage **U**:

$$(8) \quad U = K \cdot B \cdot \bar{v} \cdot D$$

The large electrode spacing **D**, the strong magnetic field **B** and the increased flow velocity \bar{v} result in a higher signal voltage, even in the presence of a low flowrate. The optimised wall thickness of the measuring tube minimises electrical eddy currents.

The measuring tube itself is cast from aluminium alloy using patented reinforcements to ensure maximum form and pressure stability. The tube is fitted with a smooth, low-friction coating made of Rilsan[®]. This polyamide coating has been successfully used for over 30 years, especially in the water supply industry. Rilsan[®] is created from biomass and has been approved by the world's leading industrial countries for use with drinking water. Rilsan[®] can withstand all of the chemicals generally used to treat drinking water including ozone, chlorine compounds and flocculants and lasts longer than, for example, some high quality stainless steels in sea water.

The power consumption of the WATERFLUX 3070 is 5000 times lower than that of conventional EMFs. Power can thus be supplied using one or two batteries. The battery is shown in Fig. 31.



Fig. 31: WATERFLUX 3070C battery

The WATERFLUX 3070 boasts an as yet unrivalled battery life of 15 years, making this EMF particularly suited to measuring points where connecting to a power supply is not a straightforward option.

The design of the WATERFLUX 3070 ensures very good overall measuring accuracy of $\pm 0.2\%$ of the measured value despite the low field current and the extremely low battery load.

As shown in Fig. 32, the WATERFLUX 3070 complies with the requirements of custody transfer as per OIML R-49 as well as the measurement instruments directive 2004/22/EC, Appendix MI-001.

There is usually no cable connection to the control system at remote measuring points. Users are thus dependent on remote data transmission when it comes to remote water sources, wells and network transitional points. In cases like these the signal converter on the WATERFLUX 3070 can be equipped using a compact module with a datalogger and a GSM transmitter, see Fig. 33.

The datalogger saves all the flow data, including the peak values and low flow-rates measured during the night. The data is then transmitted via the GSM network to the next base station and from there, if necessary, via satellite to a server that the user can then access. The battery status and error messages, like the detection of an empty pipe, are transmitted as well.

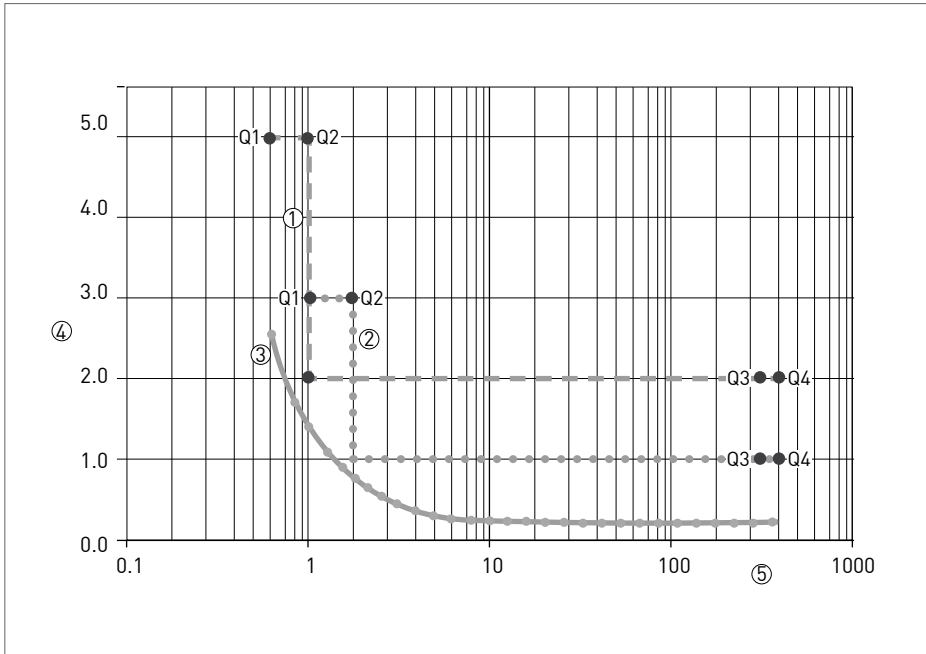

Fig. 32: Error limits for water meters in accordance with measuring instrument directive 2004/22/EC, Appendix MI-001 and OIML R49
 ① Directive 2004/22/EC MI-001, $Q_3 / Q_1 = 400$
 ② OIML R49 Class 1, Span $Q_3 / Q_1 = 250$

③ Error curve KROHNE WATERFLUX 3070, DN 100, Example
 ④ Absolute error [%]
 ⑤ Flowrate (m³/h)

The new primary head for the WATERFLUX 3070 is also compatible with the line-operated signal converters by KROHNE, the IFC 100 and the IFC 300. Therefore, even those industries that usually have a power supply at every measuring point can still benefit from the advantages provided by the unique design.

The WATERFLUX 3070 is available in all common variants. This includes the compact version as well as the remote version with a primary head featuring a protection category of IP68 or even a version in which the primary head can be installed in the ground.



Fig. 33: 070C signal converter for the WATERFLUX 3000

The lengths of the WATERFLUX 3070 also comply with the DVGW W420 and DIN ISO 13359 (WP short). This makes it simple to replace a mechanical water meter with the WATERFLUX 3070 EMF.

This electromagnetic water meter thus either meets or exceeds all industry requirements.

4.9. Two-wire EMFs

The fundamental difference between two-wire and multiwire measuring devices is that the multiwire measuring devices have a power connection which can be supplied from a separate power source to cater for any power requirements (e.g. 20 Watt).

Classic multiwire EMF

Multiwire EMFs have a separate power connection, which allows them virtually unlimited power input. **Fig. 34** shows the functional principle of multiwire EMFs.

They usually have user-friendly output options, such as a number of active outputs which feed a passive mA indicator without additional power (e.g. the classic moving-coil instrument) or actuate totalizers with current or voltage pulses.

Multiwire EMFs typically power the field coils with approximately 0.4 W to 1.5 W (and up to 15 W in special cases). This creates comparatively strong magnetic fields and high signal voltages.

However, fluctuating electrochemical voltages can in turn cause interference voltages. This can happen, for example, with inhomogeneous media, chemical reactions still in progress, noise due to low conductivity, solids, gas bubbles or ambient electrical disturbances. These interference voltages can be reliably suppressed using digital signal processing methods.

Two-wire EMF

Two-wire EMFs arose from a need for simple and low-cost wiring, as has long been used, for example, with differential-pressure sensors and orifice plates. With EMFs, this requirement was much more difficult to meet, even if the principle of the two-wire EMF bears a striking resemblance to that of the multiwire EMF. For the functional principle of two-wire EMFs, see Fig. 35.

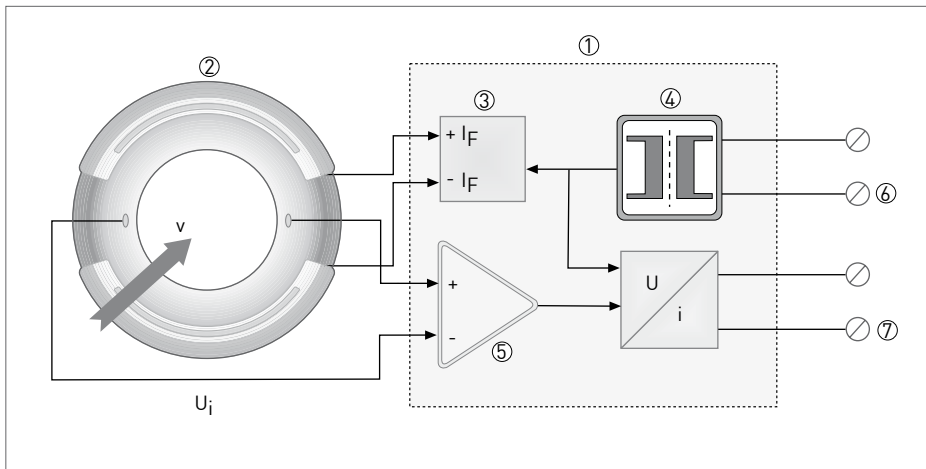

Fig. 34: Functional principle of multiwire EMFs

- ① Signal converter
- ② Primary head
- ③ Sensor supply
- ④ Mains supply
- ⑤ Signal processing
- ⑥ Power supply e.g. 230 V, 20 VA
- ⑦ Output signal 4–20 mA

Nowadays, electromagnetic flowmeters featuring two-wire connection technology, such as the KROHNE OPTIFLUX 4040, have the dynamics, reliability and accuracy of conventional four-wire EMFs.

They can be used at an electrical conductivity as low as $5 \mu\text{S}/\text{cm}$. With an auxiliary voltage of 15 V, for example, the two-wire 4–20 mA connection only makes 0.06–0.3 W available.

At low flowrates, the two-wire EMF has only a few mW available to feed the primary head and thus to generate the measuring signal. This output is still 10 to 40 times lower than that of classic multiwire EMFs.

This greatly limited the range of application for earlier two-wire EMFs. This is evident in earlier two-wire EMFs in the requirement for a conductivity of at least $50 \mu\text{S}/\text{cm}$.

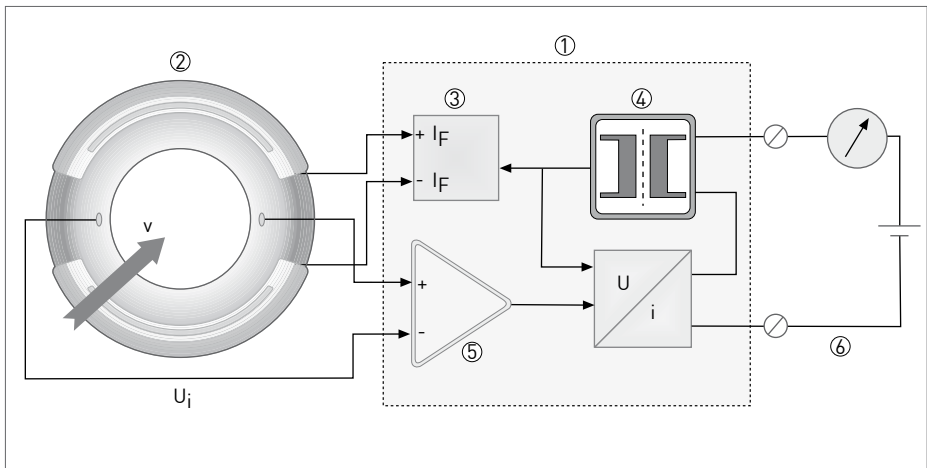

Fig. 35: Functional principle of two-wire EMFs

- ① Signal converter
- ② Primary head
- ③ Sensor supply
- ④ Mains supply
- ⑤ Signal processing
- ⑥ Output signal (supply) 4–20 mA

However, modern two-wire EMFs by KROHNE offer the same application limits as standard EMFs – at least $5 \mu\text{S/cm}$. This is achieved by using state-of-the-art electronics, new digital filtering techniques for noise suppression and other innovative technologies including, for example, intelligent power units that optimally utilise all available energy for sensor supply and noise-free signals.

For particularly difficult applications, additional application-specific digital filters can be activated via the user menu on the KROHNE two-wire EMF to block out noise.

The major benefits of two-wire EMFs include:

- Simple, low-cost wiring (savings potential of up to approx. €1,800 per measuring point as compared to multiwire EMFs);
- Easy to incorporate into "Ex" concepts, KROHNE two-wire EMFs allow the user to select freely between the "i", "e" and "d" types of ignition protection;

- Simple integration into systems with intrinsically safe "Ex" concept;
- Simple replacement of, for example, differential pressure flowmeters by EMFs without the need for rewiring;
- Low operating costs, practically maintenance-free, with diagnostic functions;
- High measuring accuracy: 0.5% of the measured value at $v > 1 \text{ m/s}$.

Modern two-wire EMFs from KROHNE thus offer an outstanding signal to noise ratio, enabling the same application range as standard EMFs despite the low power available to the primary head.

4.10. EMFs for rapid volumetric filling

In the beverage industry, the PET bottle continues to gain popularity due to its clear advantages including its shatter-proof nature, low weight and minimal transport costs.

However, PET bottles require a special volumetric filling technique because they expand differently when being filled with carbonated beverages under pressure.

The shape of reusable PET bottles changes over time due to mechanical and thermal loads such as those placed on the bottles during cleaning processes. When this happens, there is no longer a clear relation between the filling height and the filled volume, meaning that the accuracy of the filled volume can no longer be guaranteed using the classic fill level method with PET bottles.

This is how volumetric filling with special EMFs came about.

BATCHFLUX

Fig. 36 shows a BATCHFLUX 5015C from KROHNE with an installation width of just 50 mm.

KROHNE's BATCHFLUX was specially developed for volumetric filling and features the following points:

- the sturdy, only 50 mm wide stainless steel housing produced by way of investment casting;
- the inherently stable, vapour diffusion resistant ceramic measuring tube;
- CIP and SIP resistance;
- the internal device bus;
- low energy consumption;



Fig. 36: KROHNE BATCHFLUX 5015C

- the possibility of recording filling processes;
- maximum repeatability.

A BATCHFLUXEMF measures the volume flow at every filling point. This process continues throughout the entire filling process.

The EMFs transmit volume pulses (e.g. 10 pulses for every millilitre that flows through) to a batch controller in the central computer of the filling machine. The controller then integrates the volume pulses and closes the valve as soon as the preset number of pulses has been reached and the desired quantity has been filled. This process is shown in Fig. 37.

With filling times of a few seconds, this application requires repeatability of, for example, 0.2%. This includes the flowmeter uncertainty, the time response of the valves and other uncertainties in the filling process.

Additionally, there are further requirements such as full CIP and SIP capability (e.g. superheated steam cleaning followed by cold rinse), hermetic impermeability, resistance to all cleaning agents and procedures even when cleaned from

the outside, fully approved for use in the food and beverage industry as well as the fulfillment of additional customer requirements.

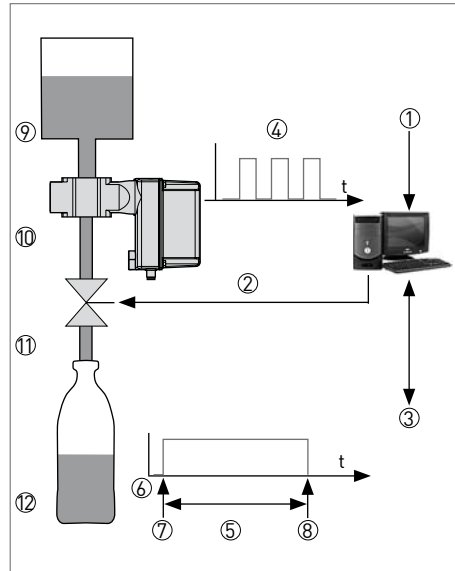

Fig. 37: Volumetric filling with KROHNE BATCHFLUX EMF

- ① Start command, when container is ready to be filled, Batch Controller (Batch Computer)
- ② Valve control signal
- ③ External communication (volume preselection, statistics)
- ④ Pulses / volume e.g. 10 pulses per ml
- ⑤ Filling time t_f
- ⑥ On / Off
- ⑦ Valve opens
- ⑧ Valve closes
- ⑨ Storage vessel (pressurized if liquid contains CO_2)
- ⑩ Flowmeter BATCHFLUX
- ⑪ Valve
- ⑫ Container Bottle, can, keg, paper or plastic container (pressurized if liquid contains CO_2)

BATCHCONTROL

The BATCHCONTROL EMF is similar to the established BATCHFLUX. However, instead of the pulse output, the BATCHCONTROL features an integrated and intelligent batch controller which can simultaneously control up to five valves.



Fig. 38: KROHNE BATCHCONTROL 5014C

This integrated batch controller can individually control the valves and valve circuits at a filling point using five contact outputs. The BATCHCONTROL offers contacts, e.g. for the filling valve, for the fine adjustment contact for a slow filling start and slow filling end with precise metering as well as a contact for the

pressure valve, bleeder valve and purge valve. The function of each of the contacts can be set using the CAN bus, depending on the filling volume and time. This bus can also be used to control each circuit while filling is in progress, depending on the position at the time. The CAN bus interface can be used to centrally adjust the target volume and other parameters while filling is in progress.

Two of these outputs can also be configured as control inputs for the following functions:

- Filling start;
- Binary input for the bus;
- Emergency off;
- Off (no function).

The most important difference between classic EMFs with pulse output and the BATCHCONTROL is shown in **Fig. 39**.

The left side of the picture shows eight filling stations on a carousel filler. The flowmeters are only equipped with one pulse output.

Each one of these outputs and valve circuits is connected to the corresponding interfaces of the process control system.

This means that in the case of valves with five controllable channels, the number of control lines can be increased by a factor of 5.

To avoid having to guide all these connections via loops from the rotating carousel to a stationary process computer, the computers with the interfaces are usually mounted directly on the rotating carousel.

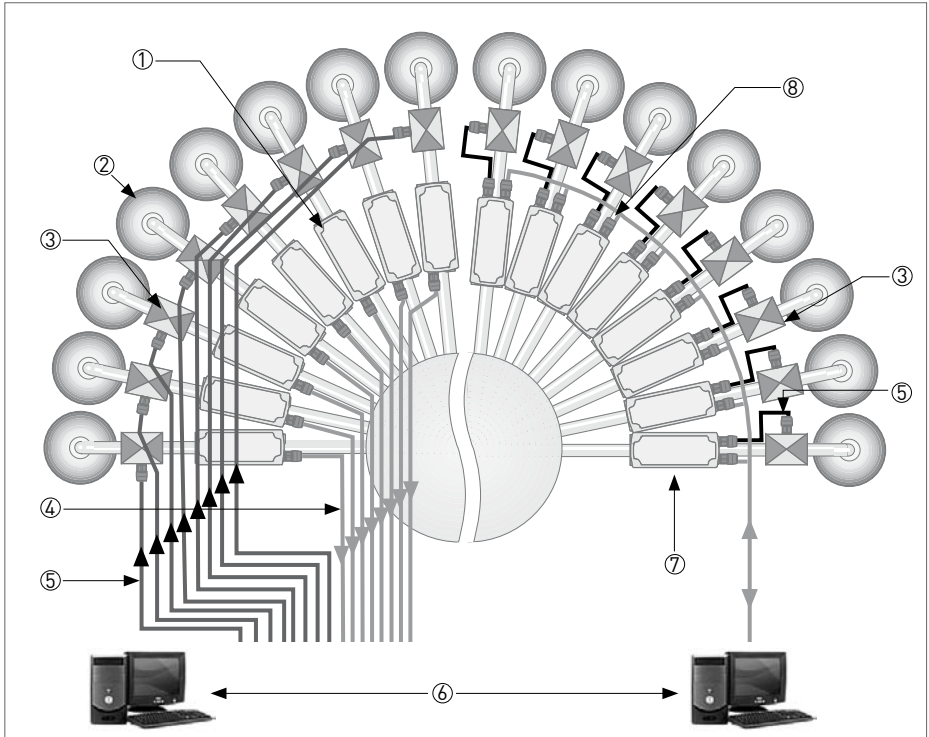

Fig. 39: A comparison of the wiring involved with a filling machine with a classic EMF and one with BATCHCONTROL

- ① Flowmeter with impulse output
- ② Package
- ③ Valves
- ④ Counting pulse lines

- ⑤ Valve control cables
- ⑥ Interface: One Batch controller and one control output per valve
- ⑦ Batch control flowmeter with integrated batch controller
- ⑧ CAN-Bus

The right side of the figure also shows eight filling stations. In this case, however, the filling stations feature BATCHCONTROL EMFs equipped with integrated batch computers and CAN-bus. This makes it possible to install the computer in a stationary position next to the carousel filler and to connect the data bus to the computer in a different way. The benefit to this is the considerable reduction in the amount of wiring required and the elimination of interfaces.

The integrated batch controller automatically performs the overfill correction. This process is made possible by a special, patented start procedure when a new device, machine or a new package size is introduced for the first time. This way, the first packages are already within the required tolerances. This is an advantage that prevents filling losses that occur when using other EMFs during the first incorrect filling processes.

BATCHFLUX and BATCHCONTROL

All measuring and operating data are transferred to the BATCHFLUX and BATCHCONTROL via the internal device bus BatchMon.

From this information, precise documentation regarding device settings and all of the filling processes is created on external PCs. This gives the manufacturer of the filling machine information about, for example, the dynamic behaviour of the valves, the flowrate during filling, the machine output and the repeatability of the filling quantity. The filling process can then be optimised. **Fig. 40** shows an example for this recording option.

At KROHNE, the filling machine manufacturer's optimum setting parameters can then be taken and the EMF can be set to these parameters prior to being delivered.

Application

BATCHFLUX and BATCHCONTROL are available in sizes DN 2.5 to DN 40. This range of sizes enables optimum adjustment to filling quantities of less than 20 ml to well over 50 l.

These application ranges can be moved up or down following appropriate testing. Applications have previously ranged from filling beverages with or without

carbonation, to milk, pharmaceutical products and latex paint and cement.

With continued development, we may even see faster filling times, smaller filling quantities and improved repeatability in future.

For a wide selection of suitable sizes see **Table 6**.

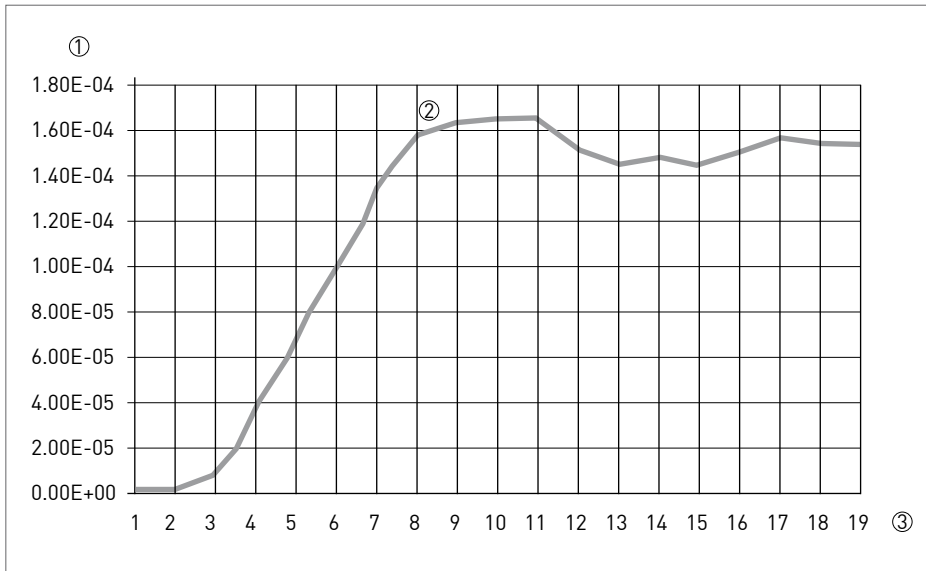

Fig. 40: Record of a filling process – “valve open”

- ① Q [m³/s]
- ② Valve opens, rising edge of flow
- ③ t [20ms / tick mark]

Advantages

BATCHFLUX and BATCHCONTROL focus exclusively on the requirements of filling machines and the operating and ambient conditions. The two EMFs for volumetric filling is a result of experience in thousands of applications, including ones with aseptic fillers. The following describes the basic benefits of the features of both EMFs.

Both EMFs feature a fully welded, extremely sturdy stainless steel housing in an investment casting with M12x1 connections. The thin and narrow design, with a width of just 50 mm, means that installation does not take up much space.

The ZrO₂-ceramic measuring tube features a surface roughness Ra of just 0.8 µm and the platinum electrodes are fused-in-place resulting in no gaps or cavities and are resistant to, for example, sodium hydroxide, nitric acid, all CIP liquids and superheated steam.

Unlike tubes with plastic liners, the measuring tube dimensions remain stable, even at high temperatures, high pressure and after many cleaning cycles using superheated steam, see **Fig. 41**. This contributes significantly to the high degree of measuring accuracy and the long-term stability of the BATCHFLUX and BATCHCONTROL EMFs.

Size [mm]	Recommended flowrate when filling	Recommended filling quantities from
DN 2.5	3–10 ml/s	10 ml
DN 4	10–30 ml/s	20 ml
DN 6	20–60 ml/s	40 ml
DN 10	60–200 ml/s	100 ml
DN 50	150–500 ml/s	200 ml
DN 25	400–1200 ml/s	600 ml
DN 32	700–2000 ml/s	1000 ml
DN 40	1000–3000 ml/s	1500 ml

Table 6: Recommendations for selecting the size of BATCHFLUX and BATCHCONTROL depending on filling volumes and flowrates

In addition, BATCHFLUX and BATCHCONTROL feature a power consumption of just 3 W, which corresponds to approx. one third of what other EMFs in this application field require, resulting in additional savings.

They also allow for viewing of the filling pattern of both the valve and the machine, making optimisation possible.

These properties allow filling machines with outstanding performance data to be designed in a cost-effective manner.

Quality assurance

BATCHFLUX and BATCHCONTROL are subject to the same quality assurance measures as any other KROHNE EMF, see Section 6.1.

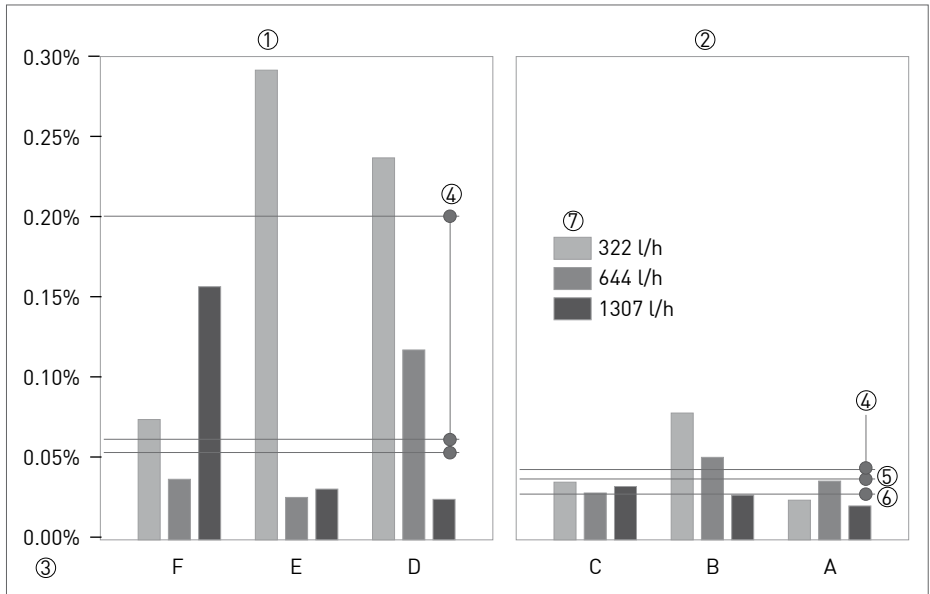

Fig. 41: Results of an independent test investigating the long-term stability of EMFs with PTFE and ceramic measuring tubes, size DN 15, after continuous stress [e.g. 600 changes 18°C / 80°C + hot acid 80°C + superheated steam 140°C]

- ① EMF with PFA liner
- ② EMF with ceramic measuring tube

- ③ Maximum difference [% of the measured value] of 10 measurements with each device for 1 h each at the specified flowrate
- ④ Average of the maximum error at 322 l/h
- ⑤ Average of the maximum error at 644 l/h
- ⑥ Average of the maximum error at 1307 l/h
- ⑦ Flowrate A-F: EMF flowmeters - test setup

KROHNE uses cyclical temperature tests to reduce the probability of failure of these EMFs to a minimum. During these tests, all electronic units must prove their reliability and accuracy in a test cabinet at cyclical temperature changes of -20°C to $+60^{\circ}\text{C}$ prior to installation. This process eliminates early failures and ensures smooth and accurate operation.

In addition, each and every BATCHFLUX and BATCHCONTROL EMF is individually calibrated by way of a direct comparison of volume. The calibration rigs used have a measuring uncertainty of less than 0.02%. This property guarantees a maximum measurement error of $\pm 0.2\%$ for EMFs for volumetric filling processes. This high accuracy allows a device to be replaced in case of error without the filling station in question having to be immediately recalibrated or corrected.

4.11. EMF probes

Given sufficiently long inlet runs of more than $20 \times \text{DN}$ and Newtonian fluids with undisturbed radial-symmetrical flow profiles, it is possible to calculate the total flowrate from the measured flow velocity.

Electromagnetic flow probes are sensing probes in a insertion design, which project into the pipeline and measure the flow velocity at its tip, see **Fig. 42**.

The advantage that electromagnetic flow probes have over Pitot tubes and vane sensors is that they measure with no mechanically moving parts, making them largely immune to contamination and insensitive to overload conditions. Also, sporadically entrained solid particles have a negligible influence on measurement.

Application

Electromagnetic flow probes can be used with sufficient conductivity and process liquids with relatively low solids content. For this reason, they are frequently used as limit switches, e.g. for pump protection or as control units with continuous flow display.

Installation in pipeline

To keep the Reynolds number dependence, even at turbulent flow profiles, to a minimum, it is recommended to position the probe tips at a distance of an eighth of the inside diameter of the tube from the inside wall of the tube.

Markings on the welding supports help with these installation instructions.



Fig. 42: Electromagnetic flow probe
(KROHNE, DWM 2000)

5. Electromagnetic flowmeters – planning

KROHNE

The use of EMFs should be planned in detail in advance. Both the field of application and the operating conditions for the EMF should be analysed prior to selecting a device. Important aspects including EMF installation, grounding and surge protection as well as important standards that must be taken into consideration when using EMFs must be considered.

5.1. Analysing the range of application and the operating conditions

Process liquid

EMFs are used in many industries. There is a wide spectrum of liquid media whose flow parameters can be measured using electromagnetic flowmeters. **Table 7** illustrates a few examples of possible process liquids in a variety of industries.

Outlined below are some important points to consider when analysing the process liquid prior to selecting the right EMF.

Industry	Typical process liquids
Food industry	Milk, liquid dough, mineral water, liquid egg, ice-cream, ketchup, yogurt, ...
Beverage industry	Beer, lemonades, wine, fruit juice, mineral water, fruit mixes, ...
Chemical industry	Acids, alkalis, suspensions, ...
Water supply	Raw water, potable water, chlorine dioxide solution, flocculants, ...
Wastewater treatment	Raw sewage, sludges up to 30% suspended solids content, ...
Power supply	Gypsum suspensions in flue gas desulphurisation systems, cooling water, measurement of thermal energy, ...
Mining	Ore slurries, drilling fluids, ...
Building industry	Plaster, screed, concrete, ...
Pulp and paper	High-consistency pulps, papermaking stock, filler, bleaching agents, screenings, ...

Table 7: Examples of process liquids in different industries

Minimum electrical conductivity

In practice, the required electrical conductivity of a process liquid is usually more than $1 \mu\text{S}/\text{cm}$. When using capacitive signal pick-up, minimum conductivities of $0.05 \mu\text{S}/\text{cm}$ are possible, see **Section 4.6**.

Depending on the EMF version and the application, a minimum conductivity of at least $0.05 \mu\text{S}/\text{cm}$ to $50 \mu\text{S}/\text{cm}$ is required. The conductivity of diluted solutions is generally greater than $5 \mu\text{S}/\text{cm}$.

Temperature

The selection of a resistant material for the measuring tube depends first and foremost on the temperature of the process liquid. When using common PTFE and PFA liners as well as ceramic measuring tubes, the maximum permissible temperature of the process liquid can be up to 180°C , for more information see **Section 5.2**.

Homogeneity

Poorly mixed process liquids with a spatially inhomogeneously distributed electrical conductivity can lead to measurement errors. Incomplete chemical reactions and the associated electrochemical processes can also lead to

interference voltages in the process liquid and on the electrodes. For this reason an EMF should always be installed in front of and never behind a mixing, injection or neutralisation point, see **Section 5.3**.

Solids content

Due to the unobstructed cross sectional tube area and the fact that solids do not influence the structure of the magnetic field, an EMF is the ideal flowmeter for the hydraulic transport of solids.

Applications with ferromagnetic suspensions e.g. with nickel or magnetite must first be discussed with the EMF manufacturer.

When used in hydraulic transport with abrasive solids content in the process liquid, sufficiently abrasion-resistant measuring tubes or liner materials must be selected.

When the flow velocity of the suspension is low, but always remaining above its critical velocity, the optimal solution is to install in a vertically ascending pipeline, see **Section 5.3**. If the flow velocity is so high that a phase separation occurs, installation in a short vertical pipeline is possible. When the flow velocity is high

enough to prevent any solid deposits, installation in a horizontal pipeline is also possible. However, when selecting the material, the heavy wear placed on the bottom of the tube by the abrasive particles must be taken into account.

Gas content

EMFs are first and foremost volume measuring devices, see **Chapter 2**. Unwanted gas content is thus one of the most common causes of measurement error. This topic is discussed in more detail below.

As with almost all volumetric flowmeters, EMFs include any gas dispersed in the liquid as part of the volume measurement. The EMF flow indicator displays a value that is too high – by exactly the same value as the gas volume. The display may also become very unstable.

The entrainment of gas in liquids is usually unintentional. It can happen for a variety of reasons. Here are some examples:

- Air can be drawn in through pump shaft seals;
- Air can be drawn in if the suction pieces in a container or tank are too close to the surface;
- Stirring devices do not only mix the product, they also draw air down at its shafts and the air enters the pipeline along with the product and gets into the EMF;
- Gases can escape from the process liquid when the pressure is not sufficiently high or in the case of cavitation, as with carbonated beverages, beer, wastewater;
- In the case of biosolids, ridges of welded seams or the edges of fittings can cause outgassing;
- Air can remain on fibres and be transported into the liquids. An example: In the pulp and paper industry, the air sticks to the pulp fibres introduced. At standard pressure, the volume content of the air is often as high as the fibre content. e.g. the air content can be as much as 10% at standard pressure with pulp containing 10% suspended solids.

Usually, when using EMFs, only the volumetric flow of the liquid phase is measured. EMFs, however, measure the volumetric flow of the total of the process liquid including the entrained gas volume. So, the reading is too high when compared to the expected measured value of the volumetric flow of the gas-free liquid or the volume of water including solids. The EMF thus displays a positive measurement deviation.

If the diameter of the entrained gas reaches a size similar to that of the diameter of the EMF electrodes, the flow indicator may stop working for a short period of time or become extremely unsteady. In horizontal pipelines, the gas can collect in the top of the pipe, which can in turn lead to measurement errors.

Such effects can be avoided or at least reduced by using gas separators, bleeder valves or vents installed upstream of the EMF. It is important to ensure that the minimum filling height in tanks or containers is sufficiently high so that no air can be drawn in through discharge connections or the blades of the stirring unit, see **Section 5.3**.

In addition, if an EMF must be installed in the vicinity of a pump, it should be installed on the delivery side and not on the suction side. The entrained gas is heavily compressed on the delivery side, causing the real volumetric proportion of the gas and the difference between the measured and the actual transported liquid volume of the liquid to be very small. When an EMF is installed on the suction side of a pump, the pressure in the product is low, even causing a vacuum. The gas volume in the process liquid, its total volume and thus also the indicated error is accordingly higher.

Fig. 43 illustrates this effect. When a pump is initially started the pressure on the suction side can decrease from 1 bar to 0.1 bar and the gas volume can increase by a factor of 10. The amount of entrained gas becomes much larger. The EMF indicator does not only indicate a seemingly significantly greater error, it can also become very unsteady as the large amount of entrained gas briefly isolates the electrodes from the liquid.

If, however, an EMF is installed in the vicinity of the delivery side of a pump, the entrained gas is heavily compressed. Due to the limited gas volume fraction, the measurement can be carried out with a high degree of accuracy.

For this reason we emphasise that EMFs should be installed where the pressure is at its highest. This does not only apply to EMFs.

However, measurement error caused by gas content in the process liquid is largely independent of the installation position of the EMF. When installed horizontally, the entrained gas mostly gathers at the top of the tube. For this reason, always ensure that the electrode axis is almost horizontal when the EMF is installed. Otherwise, the gas may insulate the electrode at the top of the tube and the measurement will then fail.

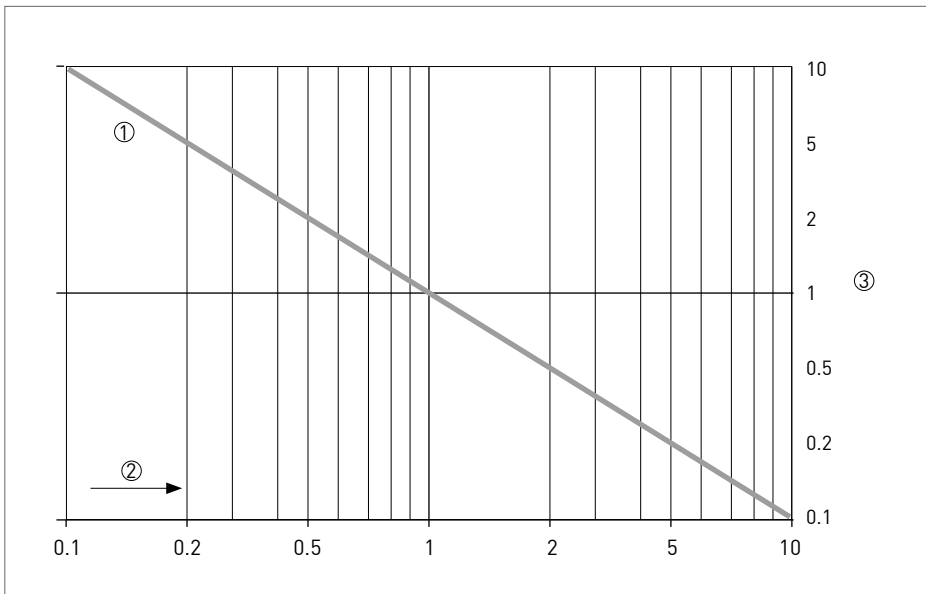

Fig. 43: Reduction of the gas volume by increasing pressure, relative gas-volume content standardised to 1 at $p_{\text{abs}} = 1$ bar

- ① Relative gas-volume content dependent on operating pressure, gas content
- ② Absolute pressure (bar)
- ③ Relative gas-volume content

With vertical installation, the entrained gas may briefly interrupt its connection to the process liquid when passing the electrodes. This may lead to a fluctuating reading.

Methods to test for gas content in media without solids

A variety of methods are suitable for testing for gas content in media without solids.

- **Listen to the pipeline:**

Hold the tip of a screwdriver on the pipeline to serve as an acoustic coupler. A trained ear can hear the noise and recognise whether or not there is gas in the liquid.

- **Using clamp-on ultrasonic flowmeters:**

Clamp-on ultrasonic flowmeters such as KROHNE's OPTISONIC 6300 enable the detection of gas content in homogeneous liquids. This gas content can lead to a significant reduction in the swirl velocity and the strength of the signal received. A process liquid free of gas, e.g. after a long period of downtime, will display a high sonic velocity and signal strength. When the medium

contains gas, the sonic velocity and possibly also the signal strength will be significantly lower.

- **Diagnosis via signal converter:**

Entrained gas flowing through an EMF, causes irregular fluctuations of the electrode voltages, so-called electrical noise. The EMF signal converters IFC 300 and 100 by KROHNE can measure this noise and output a value for the noise level as well as indicate if the adjustable limit value is exceeded.

Methods to test for gas content in products containing solids

With fibrous solids as e.g. pulp and sheep's wool, the air is attached so densely to the fibres that it is difficult to separate them. In such cases, determining the gas content in suspensions or pulps is not that easy. Electrical noise caused by the gas content disappears in the heavy electrical noise of such suspensions due to the zeta potential of the fibres and added additives. The noise measurement in the diagnosis range of the KROHNE IFC 300 and 100 signal converters cannot provide clear information here.

So-called anti-foaming agents or de-foamers have been successful in suppressing gases and helping to prevent the measurement errors caused by those gases. They are added to the suspension at the same time as the pulp is added. Observing the mass balance in the process both before and after indicates if and how much gas was removed by using the additive.

However, the entrapment of air in the process liquids can be prevented at an earlier stage. Some points can be taken into account as early as the plant planning stages.

The most important thing to take into consideration is the correct installation of the EMF on the delivery side of the pump.

Next, the suction intake points on containers, tanks or even lakes must be located far beneath the surface so that no air can be drawn into the supply line. Stirring units must be in a deep enough position so that no air is drawn into the shaft of the unit and down into the supply line.

When dealing with products that have a tendency towards outgassing, a reducer (which otherwise offers many improvements to measuring accuracy) can actually cause outgassing.

Adhering to these tips can help avoid faulty measurements caused by high gas content.

Nominal sizes

The range of application of conventional EMFs now goes from DN 1 with an interior diameter of 1 mm to over DN 3000 with an inside diameter of more than 3 m. This means flowrates from approx. 1 l/h to well over 100,000 m³/h can be measured.

Pressure ratings

Pressure ratings are based on the flange standards. The standard used is the most common pressure rating for each nominal size, for example, nominal pressure PN 40 for nominal sizes up to DN 50.

Special EMF versions with nominal pressures of over 1,500 bar are possible.

5.2. Device selection

Selecting the right device means selecting the right nominal size, the design appropriate to the intended use, suitable materials for the measuring tube and electrodes as well as the right protection category and signal converter version.

Nominal size

The nominal size (DN) of an EMF is generally the same as the nominal size of the pipeline into which the EMF is installed. A smaller nominal size for the EMF may be selected if installation is to take place between reducers. However, the nominal size of the EMF may never be larger than that of the pipeline. It is necessary to select a smaller size if:

- The process liquids have a tendency to form deposits (The flow velocity v should then be more than 3 m/s);
- Inlet conditions are unfavourable (e.g. when an unimpeded, straight inlet run as in **Section 3.1** is not possible);
- A very large measuring span is required (e.g. with DN 50 a span of 0.2–12 m/s or 2.2–84 m³/h).

If the nominal size of the EMF selected is smaller than that of the pipeline, reducers and expanders must be installed in the pipeline both downstream and upstream of the EMF, as shown in **Fig. 44**. Reducers can be considered a part of the inlet run.

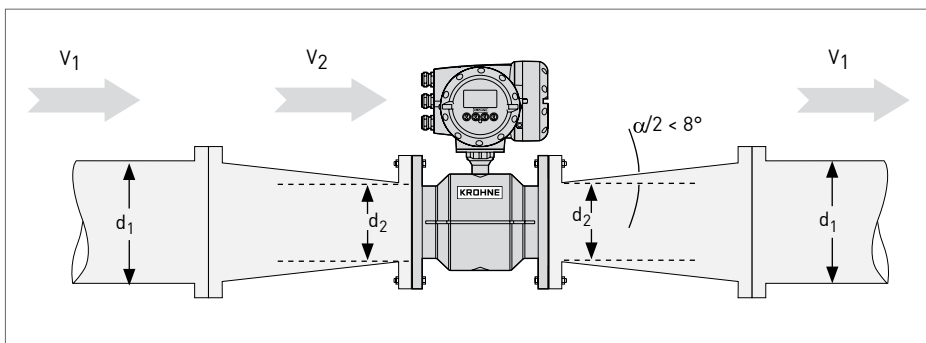

Fig. 44: Reducer upstream and downstream of EMF

This increases the flow velocity in the EMF, thus decreasing the risk of deposits. Depending on the process liquid, the flow velocity v should be more than 3 m/s.

In addition, a concentric reducer with $\alpha/2 < 8^\circ$ installed downstream of the EMF smooths out the flow profile. This allows the required inlet run to be reduced from a previous length of five times the tube diameter d_1 to approx. 3 to 4 times the inside diameter of the EMF d_2 with no additional noticeable measurement errors, see **Section 8.5**.

The measurement error of an EMF increases as the flow velocity to be measured decreases, see **Fig. 12**. If a large measuring span is required, the flow velocity can be increased by using a reducer. At low flowrates, the measurement error then decreases accordingly. The reducer can be configured so that the flow velocity v is approx. 10 or 12 m/s at maximum flow.

Additional information:

- The prescribed straight inlet runs must be provided on the inlet side between eccentric reducers and the EMF;
- Special rules for inlet runs are indicated in the approval for EMFs to be used in custody transfer;
- Check whether the usually small pressure loss is acceptable. In addition, for media with a tendency to outgas, it should be determined at what flow rate in a reducer this occurs when the discharge pressure drops, see **Section 8.2**.

Design

When selecting the design, it is important to know whether a flanged or sandwich EMF is to be used, see **Section 2.4**.

Sandwich version EMFs are less expensive than flanged version EMFs.

For a brief overview of the major selection criteria for the two designs see **Table 8**.

Measuring tube

Chemical resistance alone is not enough when selecting the material for the measuring tube. Good dimensional stability and vacuum resistance along with sufficient abrasion resistance can be equally crucial to the service life and long-term stability of the EMF.

Dimensional stability and vacuum resistance

For injected plastic liners such as PFA and PP, good dimensional stability and vacuum resistance is achieved by means of stainless steel reinforcement elements (coated with plastic) that are welded into the measuring tube. Selecting plastics or natural and synthetic elastomers that stick to the tube wall can also be helpful.

Examples of such materials include ETFE as well as natural types of rubber or synthetic rubber. Measuring tubes made of extremely dense Al_2O_3 or ZrO_2 ceramics exhibit the best properties.

Abrasion resistance

When selecting materials for use with abrasive products, the selection depends on the density, size and hardness of the solid particles as well as the flow velocity and installation site. There are also cases in which soft rubber liners can achieve a long service life. In extremely difficult cases, large nominal sizes (e.g. DN 1000) are lined with thick ceramic tiles to achieve an economically optimal service life.

Selection criteria	Sandwich	Flange
Costs (assuming otherwise identical configuration)	More favourable	Less favourable
Installation weight	Lighter	Heavier
Compatibility with flange standards (e.g. DIN, ASME, JIS)	Universal	Depends on standard
Availability of precision ceramics	DN 2.5–DN 100 or 1/10"–4"	DN 25–DN 300 or 1"–12"
Metrological properties	Equally good	

Table 8: Selection criteria for the design of EMF devices

5 Electromagnetic flowmeters – planning

Table 9 offers an overview of suitable measuring tube materials. It should be considered as a summarised guide only.

For specific applications, consult the technical data sheets and recommended information regarding materials and their resistance.

Material	Max. Process liquid temperature	Chemical resistance	Abrasion resistance	Permanent deformation under pressure / temperature	Available DN ranges	Vacuum resistant
Non-reinforced fluoroplastics, e.g. PTFE	up to 180°C	from hot alkaline solutions to hot concentrated acids	negligible to good	pronounced to negligible	10–600	poor to negligible
PFA with stainless steel reinforcement	up to 180°C	from hot alkaline solutions to hot concentrated acids	good	minimum	2.5–150	very good
ETFE	up to 120°C	from hot alkaline solutions to hot concentrated acids	very good	minimum	200–2000	very good
Hard rubber	up to 90°C	low concentration	minimum	negligible	25–3000	very good
Polypropylene with stainless steel	up to 90°C	low concentration	good	minimum	25–150	very good
Soft rubber, Neoprene	up to 60°C	low concentration	good	minimum	25–3000	very good
Polyurethane	up to 60°C	low concentration	excellent	minimum	50–1800	very good
Aluminium oxide and zirconium oxide ceramics	up to 180°C	from warm alkaline solutions (medium concentrations) to highly concentrated acids below 100°C	material with maximum abrasion resistance	maximum long-term stability, even with small DN	2.5–300	very good

Table 9: Overview of measuring tube and liner materials for EMFs

Electrode

Before selecting electrodes, first decide on the EMF configuration suitable for the measuring application. The available configurations include EMFs with conventional wetted electrodes and EMFs with capacitive, non-wetted electrodes, see **Section 2.4** and **Section 4.6**. The choice between these two configurations depends primarily on the process liquid.

EMFs with capacitive signal pick-up are best suited to applications in which the conductivity of the process liquid is less than $1 \mu\text{S}/\text{cm}$ and a minimum of $0.05 \mu\text{S}/\text{cm}$.

In addition, process liquids that are either highly abrasive or that tend to coat, which would insulate the electrodes of conventional EMFs, as is the case with latex or bitumen suspensions etc., can limit the functionality of conventional EMF electrodes. Even with chemically inhomogeneous products with a high degree of solid content or ongoing chemical reactions, e.g. following neutralisation or the injection of additives, capacitive EMFs are recommended. In all other cases, an EMF with conventional electrodes is the first choice.

If an EMF with conventional electrodes is selected for an application, both the chemical resistance as well as the electrical contact between the surface of the electrodes and the process liquid must be ensured. Selecting a material for the electrodes which does not feature sufficient chemical resistance can result in total loss of the measuring device. The formation of insulating layers on the surface of the electrodes, e.g. through passivation or electrolytically generated gas films, can also lead to measurement failure, resulting in expensive production loss.

For an overview of suitable electrode materials for particular process liquids, see **Table 10**. The materials are listed as examples only and are not meant to be used without prior testing for the application in question.

Medium	Proven electrode materials
Water, wastewater	Stainless steel, Hastelloy C 4,
Acids	Tantalum, platinum, platinum-cermet
Alkalies	Hastelloy C 4, platinum, partially platinum-Cermet

Table 10: Suitable electrode materials depending on process liquid

In all cases where the user does not have adequate experience, the chemical resistance of the electrode material and its contact reliability to the process liquid must be tested with respect to the composition, concentration and temperature of the process liquid. Most EMF suppliers will provide assistance in this respect.

Protection category

Modern EMF primary heads and compact devices generally comply with protection category IP 67 for protection against temporary submersion (max. 30 min. up to a hydrostatic head of 1m).

Remote signal converters comply with protection category IP 65 (protection against water spray) or IP 67, depending on the housing design.

For measuring systems in locations at risk of submersion (max. 30 min. up to a hydrostatic head of 1 m), the IP 67 protection category is sufficient, provided the diameter of the electrical cables has been properly selected and the cable entries have been professionally and meticulously sealed.

If the risk of longer lasting or higher submersion cannot be excluded, a remote version with a primary head featuring protection category IP 68 (protection against lasting submersion in water) must be selected. With this type of protection, manufacturers and users must agree on the typical submersion depth and guaranteed submersion time on a case by case basis. In this case, the signal converter must be installed above the highest possible submersion level, otherwise there is a risk of irreparable damage to the device.

19" rack signal converters which generally only have IP 20 protection, are protected from dust and water because they are installed in central cabinets with higher protection categories.

EMFs with remote and compact signal converters

Most EMFs are available in either remote or compact versions. Both versions often have the same primary head and signal converter electronics, in other words, the same metrological properties. However, different operating conditions and limits of use must be taken into account when selecting. Fig. 45 shows KROHNE's OPTIFLUX 4000 with the IFC 300 signal converter in the compact version.



Fig. 45: Compact version of a signal converter (KROHNE, IFC 300C)

Fig. 46 shows the same IFC 300 signal converter by KROHNE, this time in the remote version and in protection category IP 65. An IP 67 version is also available (see Fig. 11, IFC 300F).

Always select a remote version if the use of the compact version is not recommended, even if only according to one of the operating conditions outlined in Table 11.



Fig. 46: Wall-mount version of a signal converter (KROHNE, IFC 300W)

Operating conditions at the measuring point	Compact version	Remote version
High process temperature	Not appropriate	Appropriate
High ambient temperature	Not appropriate	Appropriate
Severe vibrations	Not appropriate	Appropriate
Risk of submersion	Not appropriate	Appropriate (for protection category)
Corrosive atmosphere	Not appropriate	Appropriate
Good accessibility	Appropriate	Not appropriate

Table 11: Criteria for selecting signal converter version

5.3. Installation

An explanation of how EMFs are to be installed in a measuring system in order to achieve an accurate measuring result is provided below.

When installing the remote version of an EMF, note the difference between the installation instructions for the primary head and for the signal converter.

For details and required regulations to be observed when selecting the installation site for the primary head as well as the installation process in the pipeline, consult the planning guidelines

of the respective manufacturer of the electromagnetic flowmeters.

Only the essential points to be observed when installing the primary head are addressed here.

Table 12 illustrates some typical installation situations. This includes suggestions as to the selection of the installation site for the primary head that have been proven as optimal in practice.

<p>Highest point of pipe run Avoid installation! (Air bubbles may form in the measuring tube, leading to faulty measurement.)</p>	
<p>Downpipe Avoid installation! (Open discharge.)</p>	
<p>Long pipeline Always install control and shutoff valves downstream of the flowmeter.</p>	
<p>Flow in a downpipe over 5 m in length Install air valve downstream of the flowmeter.</p>	
<p>Horizontal pipe run Install flowmeter in slightly ascending pipe section.</p>	
<p>Open feed or discharge Install flowmeter in lowest section of pipe.</p>	
<p>Pumps Do not install flowmeter on suction side of pump.</p>	

Table 12: Suggestions for selecting a suitable installation site for the primary head

- ① Automatic vent and air valve
 ② > 5 m

5.3.1. Primary head

Observe the following points when selecting the installation site for the EMF primary head for fully filled pipelines:

- Inlet and outlet runs;
- Ambient electrical conditions;
- Accessibility;
- Installation process;

The applicable requirements are outlined below.

Inlet and outlet runs

To avoid measurement errors due to distorted flow profiles, most EMF manufacturers recommend having an unimpeded inlet run with a length of at least five times the nominal size downstream of elbows and T-pieces. Control devices such as slide valves and gate valves may only ever be installed downstream of an EMF, never upstream. If the inlet runs are shorter or the control devices improperly positioned, additional errors may occur, as shown in Fig. 47.

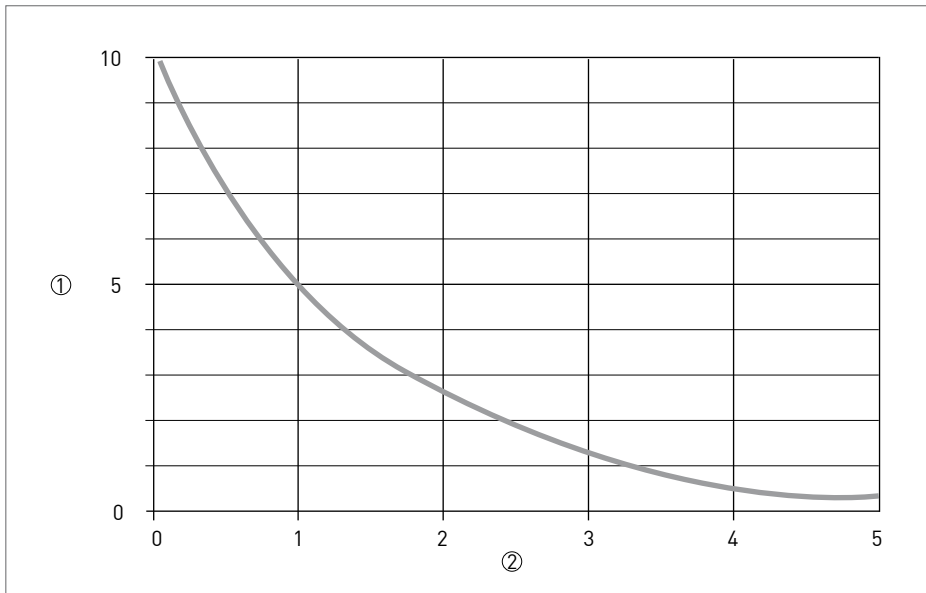

Fig. 47: Possible measurement errors when inlet runs are too short

- ① Measurement error in % of measured value
 ② Distance of the interfering element from the EMF in nominal tube sizes (DN)

By using a reducer upstream of the EMF, the inlet run can be shortened from five times the nominal size to three times the nominal size without any additional measurement error during operation, see **Section 5.2**.

Partially closed control valves or open covers and similar disruptive elements upstream of the EMF can cause significantly greater measurement errors despite the greater upstream distance, see **Section 8.5**. That is why control elements and shutoff devices such as valves, slide valves and gate valves may only be installed downstream of an EMF and never upstream. Such elements often cause cavitation which not only causes damage to the control and shutoff valves, but it can also cause additional measurement errors and potentially unsteady flow readings due to the formation of gas bubbles.

Control processes that rapidly reduce the flowrate lead to a short-term but considerable pressure drop and even vacuum shocks which can damage the EMF liner, see **Table 9**.

Ambient electrical conditions

Nowadays, EMFs can be installed in the vicinity of electric furnaces with power capacities in the megawatt range as well as in chlorine electrolysis plants only a few metres away from bus bars carrying several thousand amperes. Today's EMFs are generally immune to electrical and magnetic disturbances. However, if an EMF is to be used in such an area, the type selection and installation site should first be discussed with the relevant manufacturer just to make sure.

Accessibility

It is now seldom necessary to remove an EMF. Nevertheless, free accessibility to the measuring device should be ensured. Compact EMFs in particular should be accessible in the event that parameter settings (e.g. changing the measuring range end value) need to be changed or the electronic unit has to be replaced (e.g. to upgrade or in the case of a failure).

Installing an EMF

When installing the EMF in a horizontal pipeline, the electrode axis must be nearly horizontal. Otherwise, entrained gas may collect on the top electrode or deposits may settle on the lower electrode. Both situations can lead to measurement errors or measurement failure.

With EMFs featuring PTFE, PFA, neoprene or polyurethane liners, the liner usually covers the raised faces of the EMF flange. If this is the case, additional gaskets are not necessary as these liners are sufficiently elastic. This is provided that the mating flanges are positioned exactly parallel to one another.

The torque values for the flange bolts specified in the EMF manufacturer's installation instructions, or delivered separately, should be strictly followed otherwise the liner in contact with the raised faces of the flange or gasket may be damaged and this may lead to leakage.

In order to facilitate the installation and removal of an EMF with a nominal size from DN 200, as well as to compensate for low pipeline tolerances, it is recommended that adaptor slip sections is installed downstream of the EMF. Installing upstream of the EMF may result in eddy shedding, which would negatively affect the measuring accuracy.

Following their installation in the pipeline, the sealing stoppers in the cable glands may only be removed once the cables need to be inserted.

The cable diameter must lie within the clamping range of the cable gland, e.g. with M20x1.5 cable glands, between 7 and 13 mm. The cap nuts must be tightened very carefully. Any open connections are to be sealed with a plug. Otherwise, leaks may occur and the protection category is no longer valid. Humidity penetrating the inside can also cause the EMF to fail.

Natural and synthetic elastomer liners and the display of the signal converter must be protected from prolonged exposure to strong UV rays.

5.3.2. Signal converter

When selecting a signal converter, the choice is between a compact and a remote version.

With a compact version, the primary head and the signal converter form one unit, as shown in Fig. 48.

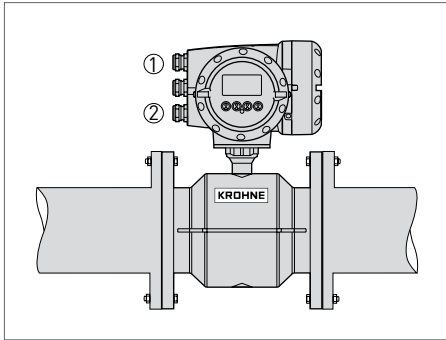

Fig. 48: EMF in compact version (KROHNE, OPTIFLUX 4300C)
 ① Power supply
 ② Output signal e.g. 4–20 mA

With the remote version, the signal converter is installed away from the primary head. They are connected to each other via signal and field current cables, as shown in Fig. 49.

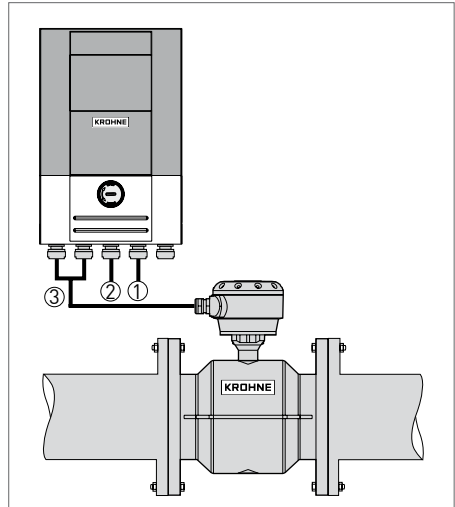

Fig. 49: EMF – remote version (KROHNE, OPTIFLUX 4300W)
 ① Output signal e.g. 4–20 mA
 ② Power supply
 ③ Field current + electrode signal

Remote versions are appropriate in the following situations.

Protection from submersion

If submersion for more than 30 minutes or a hydrostatic head of more than 1 m is expected, protection category IP67 is no longer sufficient. In this case, a primary head with protection category IP 68 must be used, see Section 5.2.

Remote signal converters (including those in protection category IP67) must then be installed above the area at risk of submersion.

Protection from excessive temperatures

As the temperature increases, so too does the failure rate of the electronic components.

For example, direct sunlight can heat up a signal converter to over 80°C. The prob-

ability of failure then increases by a factor of approx. 30, as shown in Fig. 50.

For this reason, signal converters must be protected from sunlight and other heat sources such as furnaces.

With compact EMFs, on the other hand, high process temperatures can also heat up the signal converter housing and thus the electronics contained within.

In such cases, a remote version EMF is recommended.

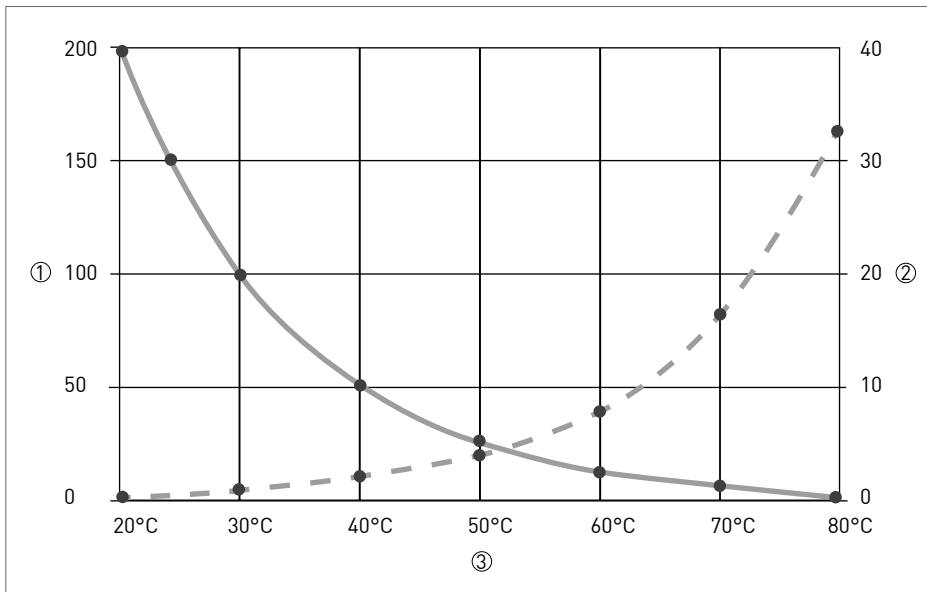

Fig. 50: Service life of electronics depending on the temperature

- ① MTBF (average service life in years)
- ② Number of failures per year for 100 devices
- ③ Temperature of the signal converter housing

Protection against vibration

Vibrations can damage the signal converter electronics. To avoid damage, signal converters should be firmly attached to a vibration-free mounting support. With compact variants, the pipeline on either side of the EMF must be supported if there is a risk of vibration or shock.

Accessibility

Regardless of any protective measures, good accessibility to the EMF must always be guaranteed. The signal converter must also be freely accessible. remote version signal converters with local display should be installed at eye level, if possible.

5.3.3. Signal cable

The electrode signal cable of remote version EMFs is a component whose influence on the function of the EMF is often underestimated. Signal cables are intended to transfer the measuring signals with millivolt amplitudes with an accuracy in the microvolt range.

Signal cables are often exposed to harsh conditions in the process. They may lie outside for many years in the rain, on wet ground, in snow at -40°C or exposed to the UV rays of the sun in Australia.

Despite such conditions, it must be possible to lay the cables without breaking in the cold and the cable should retain its insulation value for years. They should be flame resistant and have multiple shields to protect against stray pickups from external fields. In addition, the specific capacity must be small to enable great lengths in the intrinsically safe electrode circuit.

EMF manufacturers like KROHNE recommend the use of type-tested cables manufactured to specifications that take into account the relevant operating conditions.

The signal cable must be permanently wired in a location free of vibration. The cable preparation and connection must take place according to the EMF manufacturer's instructions.

Cable entries must be professionally sealed, otherwise the protection category of the EMF is not maintained.

In addition, signal cables should not be routed next to high voltage cables.

For more information on routing signal cables, especially when covering great distances between the signal converter and the primary head, see **Section 8.3.3**.

5.4. Grounding

Like all electrical equipment, EMFs must be grounded according to the applicable safety regulations. Some examples of this are protective grounding and equipotential bonding during use in hazardous areas.

Differences in potential between the process liquid and the signal converter can interfere with the measuring signal. The signal voltage is typically in the mV range and the signal converter can only process such small signals without interference and in high resolution when the difference between the potential of the process liquid and that of the reference in the first signal processing stages is not too great.

There are several possible methods available to ensure equipotential bonding, including the classic methods of grounding the process liquid. More recent grounding methods, on the other hand, do not require the process liquid to be grounded. For more details on the different grounding methods, refer to **Section 8.7**.

5.5. Surge Protection

When using EMFs in regions at risk of lightning, measures to protect against power surges are recommended.

This applies in particular to cases where the EMFs are installed in the open air and where their network and inlet/outlet pipes are connected to plants that exhibit a different grounding potential, such as in underground pipelines and sewage treatment plants.

Protective methods and elements may vary according to the manufacturer, type of device, installation site and the number of inputs and outputs used. For more details refer to **Section 8.8**.

6. Quality assurance at KROHNE



KROHNE EMFs are rugged industrial measurement devices that, after more than 50 years of industrial experience, boast high measuring accuracy, reliability and stability. These features are the result of continuous further development in technology, production and quality assurance.

KROHNE was the first EMF manufacturer to receive the ISO-9001 certification, back in 1991. This is an indication of the importance KROHNE has always attached to quality assurance.

For quality assurance, at KROHNE, each measuring device must pass a number of inspections and tests. Not only do these tests ensure compliance with the specified technical data but they also guarantee precision and reliability, even under harsh conditions.

The burn-in test and EMF calibration are among the testing methods used at KROHNE. Both tests are performed as routine tests on each device prior to delivery.

6.1. KROHNE burn-in test

The burn-in test is conducted as standard at KROHNE on every device prior to delivery and contributes to high reliability and thus high plant availability at the operator.

During this testing procedure, all signal converters are placed in a climatic exposure test cabinet where they are exposed to cyclical temperature changes from -20°C to $+60^{\circ}\text{C}$. **Fig. 51** illustrates the principle of this testing method.

During the test, a computer documents, evaluates and monitors the output signals and other measurements for compliance to specified quality characteristics including temperature coefficients, drifts, and failures, etc. are monitored.

The stress caused by this temperature change accelerates early failures of weak components at this in-house stage. These failures then no longer occur in operation, significantly increasing operational reliability.

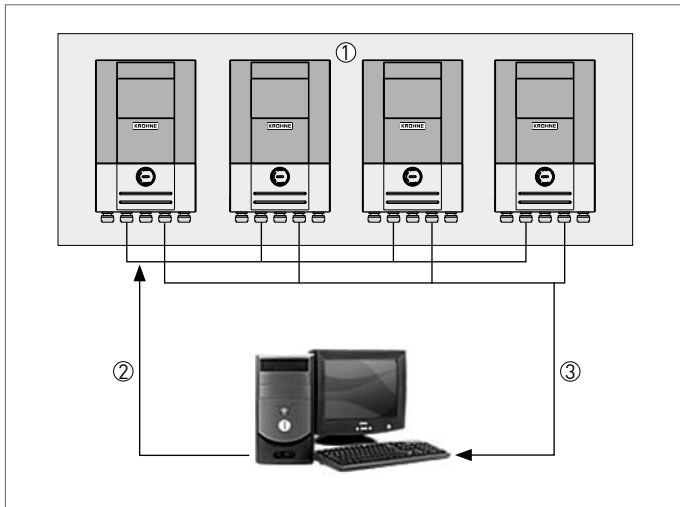

Fig. 51: Burn-in test using the KROHNE IFC 300 as an example

- ① Climatic exposure test cabinet
- ② Input signals
- ③ Output signals

Evaluating premature failures gives KROHNE insight into the quality of the parts, components and production methods used. This test enables corrective measures to be implemented early on and ensures adherence to the high degree of measuring accuracy even with changing ambient temperatures, including smooth operation outside during cold winters and hot summers.

6.2. KROHNE calibration

Before they leave the factory, every single flowmeter is wet calibrated by KROHNE on test rigs that are traceable to national and international standards.

EMF calibration at KROHNE is done as a direct comparison of volume – a method used at KROHNE for more than 40 years. The low uncertainty (0.02% or 0.04% depending on the system) guarantees a very small tolerance for the calibration data.

The EMF is installed into the measuring line of the calibration tower for calibration, as shown in **Fig. 52**. The calibration tower is then filled. Once the valve has been opened, the water flows from the calibration tower through the EMF. The calibration tower is divided into officially calibrated and precisely documented partial volumes by way of 24 precision level switches.

As soon as the water level has passed the upper level switch, it sends the EMF volume pulses through to the pulse counter. When the water level passes the preselected lower switch set by the calibration program, volume counting is shut off.

The difference between the exact known calibration volume and the volume measured by the EMF is described as the measurement error and is documented in the calibration certificate, see **Fig. 53**, which is included with every KROHNE EMF. This means that its calibration is recorded against an internationally traceable standard.

At KROHNE, calibration rigs for EMFs and ultrasonic flowmeters as shown in **Fig. 54** are accredited by RvA, the Dutch Accreditation Council, to ISO 17 025. All KROHNE EMFs are calibrated under reference conditions similar to the EN 29 104 standard.

The methods and standards applied to each calibration are monitored by NMI (the Dutch Metrology Institute) and are traceable to international standards. This is the basis for the traceability of the calibration results in the calibration certificate.

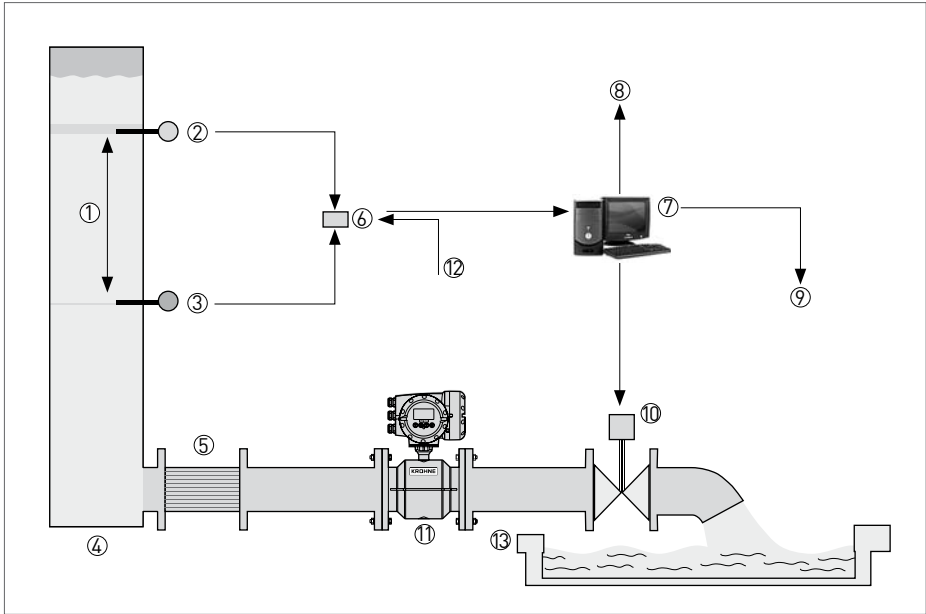

Fig. 52: Setup of KROHNE Altimeter calibration rig for EMFs to DN 3000

- ① Calibration volume
- ② Start calibration
- ③ End calibration
- ④ Calibration tower with precision level switches
Height = 43 m/volume = 500 m³
- ⑤ Flow straightener
- ⑥ Pulse counter measured vol. 200,000.0 Litre

- ⑦ Computer
- ⑧ Calibration – vol. true value * 200,000.0 Litre
- ⑨ Data output calibration certificate
- ⑩ Control valve to maintain constant flow
- ⑪ EMF (meter under test)
- ⑫ Volume pulses from EMF, e.g. 1 pulse / Litre
- ⑬ Collecting tank

The flow calibration system at KROHNE Altimeter is the largest and most accurate in the world. Here, EMFs and ultrasonic flowmeters up to DN 3000 or 120" can be calibrated. The maximum flowrate is more than 30,000 m³/h (approx. 10 m³/s).

The uncertainty is less than 0.04% at flowrates of 18 m³/h to 18,000 m³/h. The uncertainty of the KROHNE calibration rigs is considerably less than the error limits of the measuring devices to be tested.

KROHNE

**Calibration Certificate - Kalibrierzertifikat - Certificat d'étalonnage
DIN 55 350-18-4.2.2**

Customer / Kunde / Client : SYSCOM 18 SRL
 Customer Order / Bestellnummer / Commande Client : 143723
 Product / Produkt / Produit :
 Type / Typ / Type : OPTIFLUX 2000 DN 1000 mm/ 40 inch
 Sales Order / VK-Auftrag / Commande de vente : 110000318 10 3
 Serial Number / Seriennummer / Numéro de série : A08 65577
 Tag Number / Tagnummer / Repère :

Calibration Method / Kalibriermethode / Méthode d'étalonnage

The flow sensor has been calibrated against a fixed-volume tank. The calibration certificate of this tank registers the traceability to national standards, which establishes the physical units of measurements according to the International System of Units (SI).

Die Prüfung des Durchflussmessgeräts erfolgt im Vergleich zu einem Messbehälter. Die Kalibrierung des Messbehälters ist rückführbar auf Nationale Standards. Die physikalischen Einheiten sind nach dem SI-System definiert.

Le capteur de mesure a été étalonné avec un réservoir à volume fixe. Le certificat d'étalonnage de cet étalon prouve la traçabilité aux étalons nationaux qui utilisent des unités de mesures physiques selon le Système International (SI).

Test Equipment Data / Kalibrierstanddaten / Données du banc d'étalonnage

Serial Number / Seriennummer / Numéro de série : A4
 Calibration fluid / Kalibrierflüssigkeit / Fluide d'étalonnage : Water / Wasser / Eau
 Uncertainty / Unsicherheit / Incertitude : 0.03 %

Calibration Results / Kalibrier Resultats / Résultats d'étalonnage

Flow Rate Durchflussmenge Débit (%)	Set Flow rate Gewählte Durchfluss Débit réglé (m ³ /h)	Deviation Abweichung Ecart (%)
93.73	7950.4597	+0.02
20.61	1748.2020	-0.04

Calibration Data / Kalibrierdaten / Données d'étalonnage

GK : 0.0000 GK_h :
 GK1 : 7.3060 GK070 : 0.0000

Date / Datum / Date : 2008-12-04

Signature / Unterschrift / Signature :

KROHNE Abometer, Kerkweglaan 12, 3313 LC Dordrecht, Nederland, Tel. +31 (0)78 6306 300, Fax. +31 (0)78 6306 390, www.KROHNE.com

Fig. 53: Calibration certificate (KROHNE, OPTIFLUX 2000)



Fig. 54: Calibration rig (KROHNE, Netherlands)

7. The fundamental principles of fluid mechanics

Chapter 1 contained a brief introduction to the major parameters in flow measurement. They are repeated here.

Based on these parameters, what follows is a closer look at the fundamental principles of fluid mechanics.

First of all, the basic laws of fluid mechanics such as the continuity equation and the principle of energy conservation are explained.

Then, the different types of flow that may occur in a pipeline are indicated. They range from laminar to turbulent.

An explanation of the Reynolds number **Re**, an important measure of whether a flow is still laminar or already turbulent, follows. This number is also required when calculating pressure loss in the case of turbulent flows.

Finally, there is an example of how the pressure loss in a pipeline can be calculated with different types of flow, from laminar to turbulent.

7.1. Flow measurement

Superior measuring technology is now a prerequisite for exact processes, e.g. when producing and metering any liquid or gaseous product.

In addition to temperature and pressure, flow is one of the most important measurements in many processes.

Flow measurement also involves measuring both volume **V** and mass **m**. These two measured values are related via the density **ρ**:

$$(9) \quad \text{Density } \rho = \frac{\text{Mass}}{\text{Volume}} = \frac{m}{V}$$

With most processes, instantaneous values are required, in other words the flowrate as volume or mass per unit of time, e.g. in m³/h or in kg/min. **q_v** represents the volumetric flow and **q_m** the mass flow.

Many flowmeters are equipped with totalisers. These can be set as preset counters in order to automatically control filling processes. For volume flow counting, the flowrate q is integrated from time t_1 to t_2 :

$$(10) \quad V = \int_{t_1}^{t_2} q_V(t) dt$$

$$(11) \quad m = \int_{t_1}^{t_2} q_M(t) dt$$

where

V Volume

m Mass

q_V Volumetric flow

q_M Mass flow

The mass m is not affected by temperature or pressure. However, the volume V and the density ρ of liquids are slightly affected by the temperature. The impact of temperature and pressure is even greater on gases. The flow values here are based on a standard state, e.g. at 20°C and 1.013 bar.

7.2. Basic laws of fluid mechanics

The basic laws of fluid mechanics apply to flow in pipelines. However, they only apply under the assumption that we are dealing with the ideal process liquid, which

- is incompressible;
- has a constant density;
- creates no friction losses.

7.2.1. Continuity equation

The flow law, also known as the continuity equation, states that in a closed loop any change in the cross section always results in a change in the flow velocity. Cross section A and flow velocity v are thus inversely proportional. The flow volume q_V always remains constant. The continuity equation states:

$$(12) \quad q_V = A_1 \cdot v_1 = \dots = A_n \cdot v_n = \text{const.}$$

7.2.2. Principle of energy conservation

Two types of pressure exist in every flow. They are known as static pressure P_s and dynamic pressure P_d . Static pressure P_s acts in all directions. Dynamic pressure P_d , also known as back pressure, acts only in the direction of flow.

As the flow velocity v increases, so too does the dynamic pressure P_d , while the static pressure P_s drops. The principle of energy conservation, also known as Bernoulli's Law, applies to the total pressure P . This law states that in a stationary flow, the sum of the static and dynamic pressure remains constant at any point. The principle of energy conservation looks like this:

$$(13) \quad P = P_s + P_d = \text{const.}$$

Fig. 55 illustrates the effects these basic laws of fluid mechanics have on a flow in a closed pipeline with a change in cross section.

Based on the law of flow from Section 7.2.1, the process liquid is accelerated when the cross section narrows and slowed when the cross section expands. For this, working pressure W is required. Working pressure is generally defined as:

$$(14) \quad W = F \cdot s = P \cdot A \cdot s = P \cdot V$$

where

- F Force
- P Pressure
- A Cross-sectional area
- s Path
- V Volume

Following a change in the cross section between, for example, pos. 1 and pos. 2 in Fig. 55, the working pressure is thus:

$$(15) \quad W = W_1 - W_2 = (P_{s1} - P_{s2}) \cdot V$$

Assuming an ideal process liquid, this working pressure W is completely converted into acceleration energy, i.e. into kinetic energy W_{kin} .

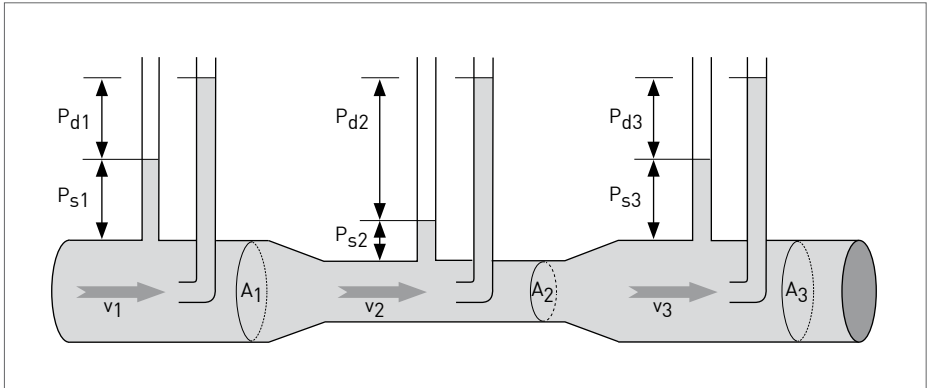

Fig. 55: Explanations regarding the basic laws of fluid mechanics

The acceleration energy is generally defined as:

$$(16) \quad W_{kin} = \frac{1}{2} \cdot m \cdot v^2 = \frac{1}{2} \cdot \rho \cdot V \cdot v^2$$

Following a change in the cross section, for instance, between pos. 1 and pos. 2 in Fig. 55, the addition of kinetic energy results in:

$$(17) \quad W_{kin} = W_{kin2} - W_{kin1}$$

and thus to:

$$(18) \quad W_{kin} = \frac{1}{2} \cdot \rho \cdot V (v_2^2 - v_1^2)$$

Merging equations (15) and (18) results in:

$$(19) \quad (P_{s1} - P_{s2}) \cdot V = \frac{1}{2} \cdot \rho \cdot V \cdot (v_2^2 - v_1^2)$$

and thus:

$$(20) \quad P_{s1} + \frac{1}{2} \cdot \rho \cdot v_1^2 = P_{s2} + \frac{1}{2} \cdot \rho \cdot v_2^2$$

This means that the total pressure at both positions always remains constant. Bernoulli's Law can thus be taken from equation (13) and formulated as follows:

$$(21) \quad P = P_s + \frac{1}{2} \cdot \rho \cdot v^2 = \text{constant}$$

The component P_s stands for the static pressure component created by the movement of tiny particles in the process liquid, which acts equally in all directions.

$\frac{1}{2} \cdot \rho \cdot v^2$ stands for the dynamic pressure component which, accordingly, only acts in the direction of flow.

Equation (20) shows that the static pressure downstream of a reducer is lower than it is upstream:

$$(22) \quad P_{s2} = P_{s1} - \frac{1}{2} \cdot \rho \cdot (v_2^2 - v_1^2)$$

7.3. Flows

The flow in a pipeline can be either laminar or turbulent. Both types of flow are explained in more detail below. Mathematical principles can only be analytically determined with laminar flows.

7.3.1. Laminar flows

Flow is considered to be laminar when no vortex is created. An internal friction is created in the process liquid as a result of the action of force between the molecules. This force, also known as viscosity, is especially great when the molecules are difficult to move.

The example in Fig. 56 illustrates the laminar movement of adjacent layers as a result of internal friction. This property is termed dynamic viscosity η . The example assumes that the fluid adheres to both of the grey plates, i. e. layer v_0 rests, and to the permanent plate too ($v = 0 \text{ m/s}$), and the layer v moves with the velocity v of the moving plate.

Between the two parallel grey plates with the surface A , there is fluid at a distance of x , shown here as a model in 6 layers. Ideally, the velocity decreases

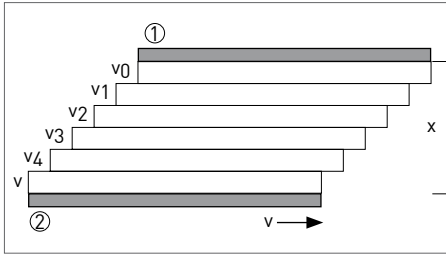

Fig. 56: Example for layers of fluids

- ① permanent plate $v = 0 \text{ m/s}$
- ② moving plate

linearly from the moving to the stationary plate. The lowest layer v exercises tangential force on the layer v_4 , which then moves on with the velocity v_4 . This fluid layer acts on the one above it and results in velocity v_3 . In this way, each layer accelerates the next and is then in turn slowed down in accordance with the reaction principle. Thus, in order to move the moving plate, a force F is necessary. This force is proportional to surface A of the plate, its velocity v and to the distance x between the two plates:

$$(23) \quad F \sim A; F \sim v; F \sim \frac{1}{x}$$

The following is valid:

$$(24) \quad F \sim \frac{A \cdot v}{x}$$

Accordingly, the force F is:

$$(25) \quad F = \eta \cdot \frac{A \cdot v}{x}$$

Which means, the dynamic velocity η :

$$(26) \quad \eta = \frac{F}{A} \cdot \frac{x}{v}$$

The result is the shear stress τ :

$$(27) \quad \tau = \frac{F}{A} = \frac{\eta \cdot v}{x}$$

Dividing by the density ρ results in the dynamic viscosity η :

$$(28) \quad \tau = \frac{\eta \cdot v}{x}$$

The dynamic viscosity of liquids decreases as temperature increases.

The consequence of these laws for pipelines is that the process liquid molecules move in layers parallel to the axis when the flow is laminar. The velocity v changes with the radius r of the pipeline, that is at the same distance r_i to the tube axis, the velocity v_i is the same. The velocity is greatest in the middle of the pipeline and at the walls of the tube it is $v = 0 \text{ m/s}$. Fig. 57 illustrates the flow profile and velocity distribution in a laminar flow.

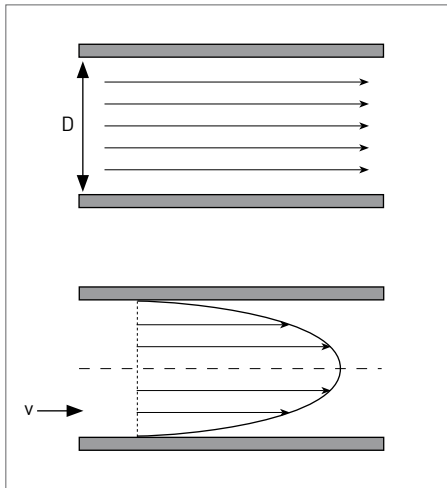

Fig. 57: Laminar flow

7.3.2. Turbulent flows

A flow is turbulent as soon as a vortex is created. In the process, great flow resistances occur as well as forces that work against the direction of movement of the process liquid, thus slowing it down. Flow resistance increases with the square of the flow velocity. Fig. 58 shows the flow profile and the velocity distribution in a turbulent flow.

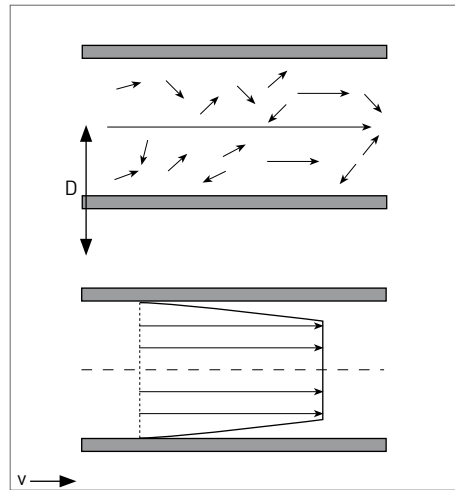

Fig. 58: Turbulent flow

7.4. The Reynolds number Re

The Reynolds number Re is a dimensionless number that gives a measure of the ratio of inertial forces to viscous forces. This number allows comparisons between process liquids and also allows statements to be made about the pattern of the flow profile. The Reynolds number Re is also an important parameter when it comes to calculating pressure losses in pipelines.

To maintain a constant Reynolds number with a constant pipeline diameter, the flow velocity v , for example, must be increased if the dynamic viscosity η increases.

The following applies to pipelines:

$$(29) \quad Re = \frac{\rho \cdot v \cdot D}{\eta}$$

where

ρ the density of the process liquid

v the mean flow velocity

D the diameter of the pipeline

η the dynamic viscosity

As long as $Re < 2320$ the flow is laminar. This is the critical value at which the

transition from laminar to turbulent flow takes place. Thus, if $Re > 2320$, the flow is turbulent. In practice, this transition point is dependent on a variety of basic conditions, e.g. upstream disturbances or vibrations in the pipeline.

7.5. Pressure loss in incompressible flows

Pressure losses caused by flow and friction resistances always occur in flows. The extent of these losses in pressure is determined by, amongst others, the type of flow in the pipeline. The laws applicable to pressure losses in both laminar and turbulent flows are described below.

Pressure loss and flow resistance in laminar flows

Any pressure loss in a laminar flow is primarily caused by flow resistance, as shown in Fig. 59.

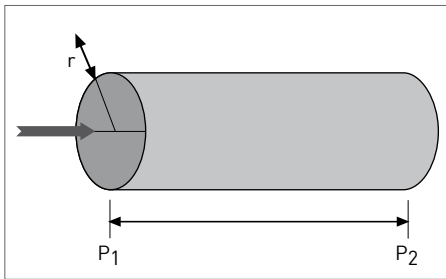

Fig. 59: Flow resistance

The following applies to a pressure loss ΔP between two points in a straight, closed pipeline:

$$(30) \quad \Delta P = P_1 - P_2$$

The flow resistance R is generally defined as the pressure loss ΔP per flow volume q_v :

$$(31) \quad R = \frac{\Delta P}{q_v}$$

According to Hagen-Poiseuille, the following simplified equation applies:

$$(32) \quad R = \frac{8 \cdot \eta \cdot l}{\pi \cdot r^2}$$

This results in a pressure loss ΔP :

$$(33) \quad \Delta P = R \cdot q_v = \frac{8 \cdot \eta \cdot l}{\pi \cdot r^2}$$

The pressure loss ΔP is thus proportional to the length of the pipeline l .

Pressure loss and pipe friction coefficient in turbulent flows

Mathematical laws cannot be analytically determined in a turbulent flow. Of particular note here, among other things, is the temporally non-constant mean flow velocity as well as the surface property or roughness of the pipeline walls.

The flow is laminar in a thin boundary layer near the wall. Here, a distinction is made between hydraulically smooth and hydraulically rough as well as a transition area.

In addition to the Reynolds number **Re**, the pipe friction coefficient **λ** is also an important parameter for which the following generally applies:

$$(34) \quad \lambda = f \left(\text{Re}, \frac{k}{D} \right)$$

where

k mean height of all wall unevenness

D diameter of the pipeline

Re Reynolds number

This results in a pressure loss coefficient **ζ**, which can be defined as:

$$(35) \quad \zeta = \lambda \cdot \frac{k}{D} \approx \text{Re}^{7/8} \cdot \frac{k}{D}$$

The starting values for this pressure loss coefficient **ζ** in turbulent flows amount to approximately 0.22.

Table 13 contains a few empirically determined formulas which can be used to calculate the pipe friction coefficient **λ** for both a hydraulically smooth as well as a hydraulically rough area and for the transition area.

7 The fundamental principles of fluid mechanics

Hydraulically smooth	Transition area	Hydraulically rough
Pipeline coefficient λ:		
$\lambda = f(\text{Re})$	$\lambda = f(\text{Re}, k/D)$	$\lambda = f(k/D)$
for $\text{Re} < 2320$ (according to Prandtl): $\lambda = [2\lg(\text{Re} \sqrt{\lambda}) - 0.8]^{-2}$	(according to Colebrook): $\lambda = [1.74 - 2\lg(2 \cdot \frac{k}{D} + \frac{18.7}{\text{Re} \cdot \sqrt{\lambda}})]$	(according to Nikuradse): $\lambda = [2\lg(\frac{D}{k}) + 1.138]^{-2}$
for $2320 < \text{Re} < 10^5$ (according to Blasius): $\lambda = \frac{0.3164}{\sqrt[4]{\text{Re}}}$	(according to Pham): $\lambda = [2\lg(\frac{k}{3.7 \cdot D} - \frac{4.52}{\text{Re}} \cdot \lg \frac{7}{\text{Re}} + \frac{k}{7 \cdot D})]$	
for $10^5 < \text{Re} < 10^8$ (according to Herrmann): $\lambda = 0.0032 + 0.221 \cdot \text{Re}^{-0.237}$		
Pressure loss coefficient ζ:		
$\zeta < 5$	$5 < \zeta < 225$	$\zeta > 225$

Table 13: Determining the pipe friction coefficient in turbulent flows

The pressure loss ΔP can then be approximately calculated according to:

$$(36) \quad \Delta P = \lambda \cdot \frac{l}{D} \cdot \frac{\rho}{2} \cdot v^2$$

with l length of the pipeline

8. The theory of electromagnetic flowmeters

KROHNE

As **Chapter 2** described the fundamentals of electromagnetic flow measurement in detail, this chapter offers a more thorough look into the scientific theory behind the EMF.

First, we will review the function of the EMF measuring principle.

Then, we will go into the physical background of the basics of the electromagnetic measuring principle.

This is followed by an introduction to the creation and processing of the EMF measuring signal, making clear how EMFs developed from expensive and sensitive individual devices to sturdy, maintenance-free process and precision measuring devices.

Finally, the theory surrounding signal converters, frequently occurring flow profiles, empty pipe detection, grounding and surge protection are delved into in detail.

8.1. Measuring principle

Electromagnetic flow measurement is based on Faraday's law of induction. According to this law, a voltage is induced in a conductor when it moves through a magnetic field. The functional principle of electromagnetic measuring devices is also based on this law of nature.

A voltage is also induced when a conducting fluid flows through the magnetic field of an EMF, as shown in **Fig. 2**.

In a tube with a diameter **D**, the process liquid flows through a magnetic field created perpendicular to the direction of flow with a strength equivalent to **B**. Due to its movement through the magnetic field, an electrical voltage is induced in the process liquid. The induced voltage **U** is thus proportional to the flow velocity **v** and thus also to the volume throughput.

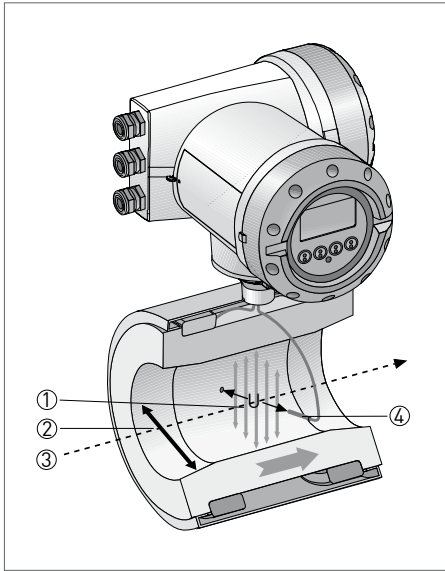

Fig. 60: Measuring principle of electromagnetic flowmeters

- ① B = induction (magnetic field strength)
- ② D = tube diameter
- ③ \bar{v} = mean flow velocity
- ④ U = voltage = $k \times B \times \bar{v} \times D$
 k = device constant

With k as the dimensionless device constant, the voltage U is:

$$(37) \quad U = k \cdot B \cdot \bar{v} \cdot D$$

where

- k device constant
- B magnetic field strength
- \bar{v} mean flow velocity
- D tube diameter

The following applies to a circular tube cross section:

$$(38) \quad q = \bar{v} \cdot \pi \cdot D^2 / 4$$

Making the displayed volume flow q :

$$(39) \quad q = U \cdot \frac{\pi \cdot D}{4 \cdot k \cdot B}$$

The induced voltage signal is then picked up via two electrodes in conducting contact with the process liquid and supplied to a signal converter.

The signal converter eliminates interfering signals and amplifies the measured value to make suitable measuring signals available at its outputs for process control e.g., an active current of 4–20 mA.

The magnetic field in the primary head is generated by two field coils which are supplied with an almost rectangular current from the signal converter. This current accepts alternating positive and negative values. Alternating positive and negative flow-proportional signal voltages U_i are created by the flow-proportional magnetic field strength B . The signal converter subtracts these positive and negative signal voltages present at the electrodes from one another. This process always occurs when the field current has reached its stationary value, suppressing the induced interfering voltages and slowly changing (compared to the measuring cycle) external or noisy voltages.

8.2. Physical background

Faraday discovered the law of induction in 1832. This law describes a voltage U induced in a conductor as it moves through a magnetic field:

$$(40) \quad \bar{U} = (\bar{v} \times \bar{B}) \cdot L$$

where

\bar{U} induced voltage (vector)

\bar{B} magnetic field strength (vector)

L length of the conductor moved

\bar{v} velocity of the conductor moved (vector)

Following this discovery, in the same year, Faraday attempted to measure the flow velocity of the Thames by determining the voltage induced in the flowing water by the earth's magnetic field.

B. Thürlemann and J. A. Shercliff were the first to investigate the properties of electromagnetic flowmeters.

For a theoretical model with an infinitely long homogeneous magnetic field and point electrodes, it was established that the measuring voltage is independent of the flow profile in the measuring tube, provided the flow profile is radially symmetrical. On these assumptions, we obtain the flow-proportional signal voltage U as:

$$(41) \quad U = k \cdot B \cdot \bar{v} \cdot D$$

where

- k device constant
- B magnetic field strength
- \bar{v} mean flow velocity
- D tube diameter

Shercliff recognized that the contribution of the finite elements of flow in the measuring tube towards the total signal voltage is weighted as a factor of their location in the measuring tube, and created the term valence vector. Proceeding from Maxwell's equations, he showed that the following applies to the electrode signal voltage U :

$$(42) \quad \bar{U} = \int_{x, y, z} (\bar{W} \times \bar{B}) \cdot \bar{v} \, dx \, dy \, dz$$

This space integral describes the area of the measuring tube permeated by the magnetic field. This integral cannot be solved for general purposes but a solution was found for the theoretical model and for rotation symmetrical flow profiles.

The valence vector \bar{W} determines the contribution of the finite elements of flow towards the signal voltage as a function of their location in the measuring tube. According to this, the total signal voltage U can be approximated as the sum of the contributions of the finite elements of flow between the electrodes. **Fig. 61** shows the components of the valence vector \bar{W} in the direction of the electrode axis on the electrode level.

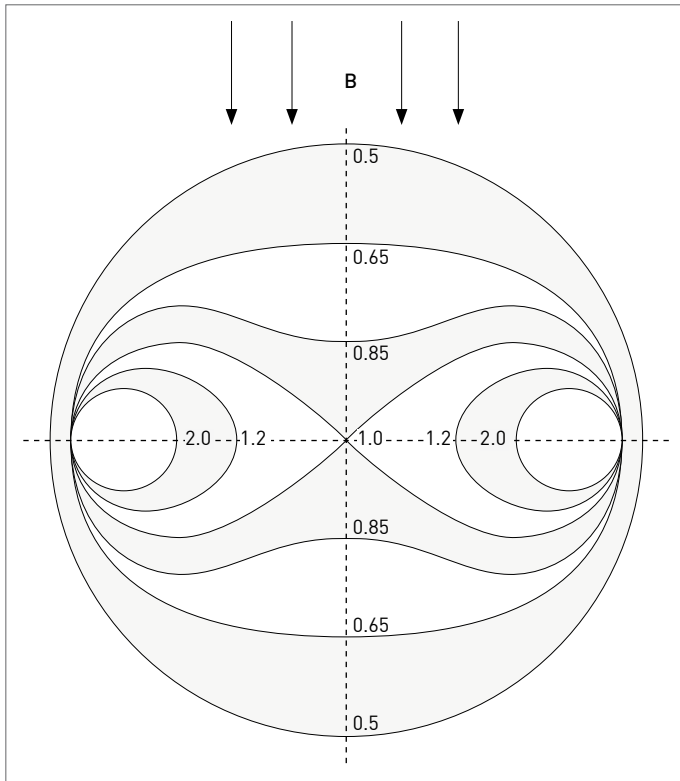

Fig. 61: x-component of the valence vector W according to Shercliff on the electrode level

Designs following this Shercliff theory have the advantage that the rotationally symmetrical changes of the flow profile such as the transition from a laminar to turbulent flow profile, have no influence on the measuring accuracy.

Interest in the EMF grew in the industry in the years following 1960. The basic conditions of the Shercliff theory determined the practical design of electromagnetic flowmeters until approx. 1967.

In order to simulate the basic condition of having an "infinitely long and homogeneous magnetic field", extremely long field coils were used. These were similar in design to the windings of large electric motors.

However, in some respects this design proved impractical for industrial use. These included the extremely long length of the EMF needed for large nominal sizes (more than five times

the inside diameter of the tube), the great weight and especially the high manufacturing costs which increased significantly for the larger nominal sizes needed for this field of application. In addition, this version exhibited noticeable measurement errors in the asymmetrically distorted flow profiles due to the high valence near the electrodes. The considerably higher sensitivity close to the electrodes is the result of the basic conditions of the Shercliff theory.

Inhomogeneous magnetic field

The idea of using inhomogeneous magnetic fields to reduce the induction B near the electrodes was one thing that led to this development. The result is a smaller term near the electrodes, reducing the influence of asymmetrically distorted flow profiles on measuring accuracy.

Another contributing factor was that shorter field coils could be used. This made it possible to reduce the length of large EMFs from what had typically been five nominal sizes to just one nominal size in the case of very large DN's.

These were the first steps towards reasonably priced EMFs for a wide range of applications.

Many of the literary sources contain investigations into inhomogeneous magnetic field patterns with the objective of reducing the effect of asymmetrical flow profiles on the measuring accuracy of the EMF. They also offer a more detailed overview of the theory of electromagnetic flowmeters and its practical versions.

EMFs with inhomogeneous magnetic fields have been on the market since around 1967 but work on the theory and testing of properties continued for many years.

8.3. Signal generation and processing

The flow-proportional signal voltage at the electrodes amounts to only a few **mV**, possibly even only a few **μV** when flow is very low.

8.3.1. Internal resistance

The available power of this signaling circuit is generally some 10–18 W to 10–12 W. For reliable and interference-free generation and transmission of such small signals, special measures are required such as shielding of the signal cable and grounding of the sensor.

The signal voltage picked up at the electrodes can be superimposed by electrochemical interference voltages that are formed at the interface between electrodes and the process liquid. These interference voltages can be over 100 mV and are exponentially greater than the signal voltage to be evaluated. Additionally, line-frequency interference voltages are often superimposed on the signal voltage.

8.3.2. AC and DC fields

One way to distinguish between the interference dc voltage and the signal voltage is to deliberately vary the signal voltage over time by modulating the strength of the magnetic field or induction **B**, i.e. of the field current in the coils of the primary head.

With the induction **B = 0**, there is a signal voltage **U = 0**. If the field current through the coils is increased, induction **B** and thus signal voltage **U** increase accordingly. When the coil current is reversed, in other words **B** is inverted, **U** will likewise reverse the sign. This effect is exploited in various forms in EMFs to release the signal voltage from the electrochemical interference dc voltage.

EMF with sinusoidal ac field

The first industrial EMFs had field coils simply connected to the line ac voltage.

The line-frequency and sinusoidal field current generates a line-frequency and sinusoidal magnetic field which means that the following applies:

$$(43) \quad \mathbf{B}(t) = B \cdot \sin(\omega \cdot t)$$

Accordingly, the following applies to the induced signal voltage \mathbf{U} :

$$(44) \quad \mathbf{U}(t) = k \cdot B \cdot \sin(\omega \cdot t) \cdot \vec{v} \cdot D$$

This signal ac voltage $\mathbf{U}(t)$ is very easy to distinguish from the electrochemical dc voltage and can be further processed without being affected by it.

However, interfering side effects occur with ac field EMFs. These cannot be completely eliminated, thus meriting mention here.

The sinusoidal magnetic field induces eddy currents and thus interfering voltages in all of the electrically conducting parts of the primary head e.g. in the wall of the measuring tube, in the magnetic plate, in the process liquid as well as on the measuring electrodes. The interference voltage is often superimposed on

the signal voltage \mathbf{U} , making it erroneous. This results in faulty measuring results. The signal converter cannot distinguish between the interference voltage and the signal voltage because both voltages have the same frequency and waveform but no rigid phase relation.

The eddy currents in the wall of the measuring tube have an additional negative effect. They generate their own magnetic fields which oppose the signal field of the coils, thus weakening it. The strength of the magnetic fields depends on the electrical conductivity of the measuring tube which, in turn, is heavily dependent on the temperature when it comes to stainless steel tubes. This causes additional temperature coefficients and thus measurement errors.

EMFs still operated with line-frequency ac fields are becoming rare and obviously are no longer available for new plants. They are very sensitive to all line-frequency field currents and external fields both on and near the pipeline. The signal converter cannot fully discriminate between the line-frequency interference voltages and the line-frequency signal voltages.

This thus leads to errors of the display and makes it periodically necessary to calibrate the zero point with line-frequency ac field EMFs. To do this, the flow must be shut off.

AC field EMFs are now rarely used in new plants. They have been replaced almost completely by EMFs with pulsed dc fields.

EMF with pulsed dc field

It was only with the introduction of the pulsed dc field in 1973 that EMFs became sturdy, maintenance-free process and precision measuring devices.

For EMFs with pulsed dc fields, the field coils of the primary head, as shown in **Fig. 62**, are supplied with a precisely controlled current that has an approximate trapezoidal waveform. The interference voltage peaks that occur briefly due to changeover of the field current are simply suppressed. This is described below.

The signal converter does not accept the electrode voltage until the interference voltage peaks have decreased sufficiently. This is the case when the field current, and induction, are constant (as with a dc field). The influence of these interference

voltages on the measuring accuracy is eliminated.

Line-frequency interference voltages are easier to suppress because the field and signal frequencies of EMFs with pulsed dc fields have been defined as deliberately deviating from the line frequency. The signal converter's signal processing system can therefore readily distinguish the signal voltage with its other frequency from the line-frequency interferences.

The electrochemical interference dc voltage can be suppressed by using a high pass capacitor coupling or by calculating the difference between a succession of sampled values or by using more complex techniques such as the interpolation method introduced by KROHNE in 1973.

This completely avoids side effects such as those experienced with EMFs with ac fields.

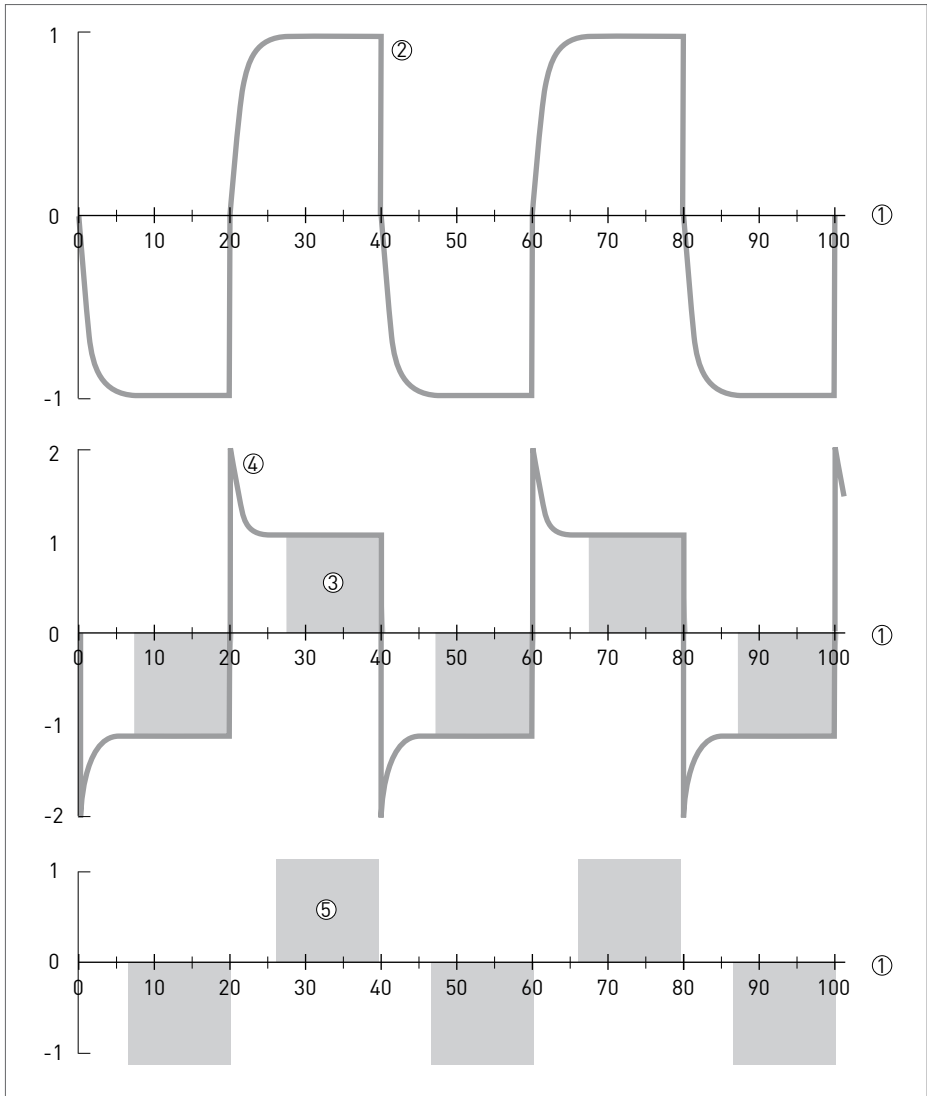

Fig. 62: Typical time characteristic of field current and electrode voltage in an EMF with a pulsed dc field

- ① t [ms]
 - ② Field current, induction
 - ③ Sampling interval
 - ④ Electrode voltage
 - ⑤ Sampled signal voltage
- $$U = k \cdot B \cdot \dot{v} \cdot D$$

8.3.3. Signal cables with bootstrap

The electrode circuit of an EMF, as shown in Fig. 63, provides signal voltages with the source impedance Z_i . The size of Z_i can be roughly estimated at:

$$(45) \quad Z_i \approx \frac{10^6}{\sigma \cdot d}$$

where

Z_i source impedance [Ohm]

σ conductivity [$\mu\text{S/cm}$]

d electrode diameter [cm]

Therefore, if the signal cable is very long, the line capacitances C_1 , C_2 are in turn very great. The almost rectangular signal voltage U_i must periodically reload these line capacitances via the source impedance Z_i (e.g. the resistance of the liquid and also that of the deposits on the electrodes). The shape of the signal voltage U_i is rounded in the process. The rounded voltage U_s then arrives at the signal converter. This can lead to a noticeable loss in measuring accuracy.

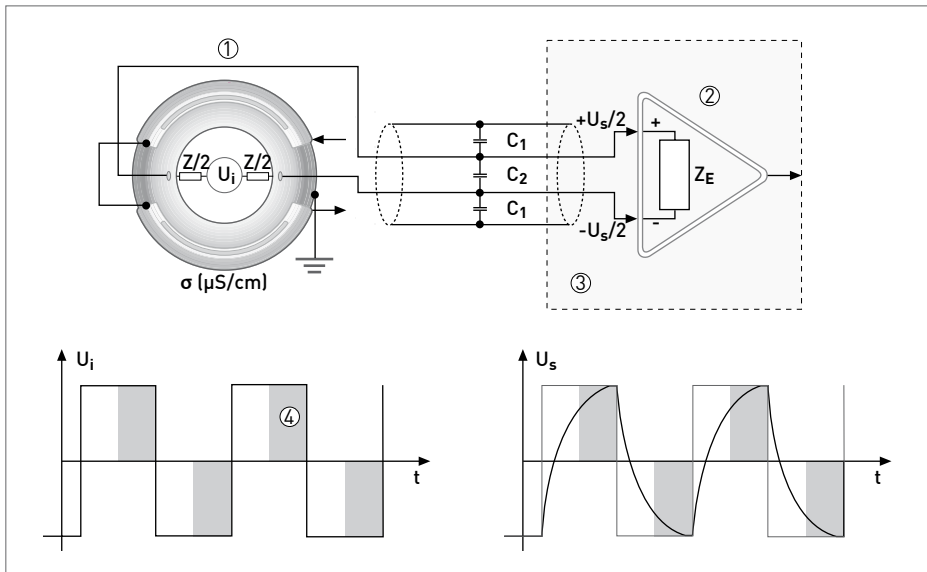

Fig. 63: Line capacitance and signal distortion in long signal cables without single conductor shields
 ① Primary head

② Input amplifier
 ③ Signal converter
 ④ Sampling interval

For this reason, most EMF manufacturers provide detailed information about permissible cable lengths depending on the conductivity of the process liquid as well as on the type of device and cable.

In the scope of its diagnostics, the KROHNE IFC 300 signal converter monitors whether the signal voltage in the signal converter has properly engaged. If not, an error message is output.

When there is a great distance between the primary head and the signal converter, when conductivity is low or when conductivity decreases strongly or in the event of high-impedance electrode contamination, the so-called "bootstrap" technique must be used, see Fig. 64.

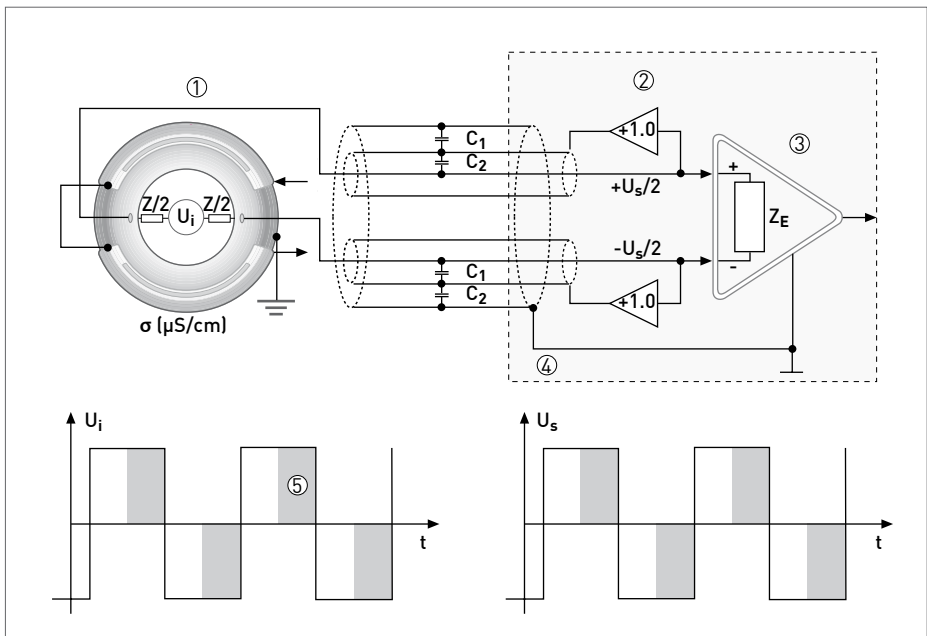

Fig. 64: Line capacitance and signal distortion for signal cable with shielding (Bootstrap)
 ① Primary head
 ② Impedance converter

③ Input amplifier
 ④ Signal converter
 ⑤ Sampling interval

This also applies to remote version EMFs with very small nominal sizes. The electrodes on an EMF with a DN 2.5 mm have a diameter of approx. 1 mm. The source impedance of the signal circuit is thus naturally high.

For this reason, signal cables as depicted in **Fig. 64** are recommended for these nominal sizes. The additional total outer shield is not shown here. Each signal conductor has its own shield that is brought to the potential of its signal conductor using an impedance converter at low resistance with the amplification $V = 1$. Because there is no longer a voltage difference between the signal conductors and their shields, no current flows via the line capacitance C_1 between conductors and shields. These capacitances are then virtually zero. The currents that flow via C_2 to the total shield have no effect because they do not have any retroactive effect on the low resistance outputs of the impedance converter.

The result is shown in **Fig. 64** below. The signal voltage U_s at the input of the signal converter is now an exact copy of the unstressed induced voltage U_i .

This "bootstrap" wiring costs more than wiring with a common shield for both signal conductors. However, the bootstrap method ensures high measurement stability and measuring accuracy, even with unfavourable process liquid conditions and with high-resistance electrode contamination.

8.4. Signal converter in detail

When it comes to electromagnetic flow measurement technology, signal converters have different functions to perform, as outlined below.

For EMFs with bipolar pulsed dc fields, the signal converter also functions as a supply device to generate the magnetic field in the field coils through an active current, see **Section 8.3**.

However, the main function of the signal converter is to process the signal voltage. It is the signal converter's task to amplify the signal voltage without feedback. The input amplifier of the signal converter must thus be of extremely high impedance so that the internal resistance of the electrode circuit has no effect on the measuring accuracy. The amplified electrode voltage is then converted into digital values. Filters are then used to free the signal voltage of any superimposed interference which may be exponentially higher than the measured value itself. Complex digital filter techniques are used to do this. The signal converter then scales the digital values in accordance with the specified operating parameters (such as full scale range, size of the sensor,

span of the mA output, etc.) and converts the scaled digital values into suitable standard signals for the process (e.g. 4–20 mA, pulses scaled in volumetric units for volume flow counting or also digital values directly transferable via computer interfaces to process control systems). These values can also be shown on the local display.

Since 1995, signal converters with an internal device bus (such as IMoCom = Internal Modular Communication) have been used, see **Fig. 65**. Following conversion, the induced signal voltage is digitally filtered by the first microprocessor into digital values, scaled in accordance with the set operating parameters and transferred to an internal device bus with different output units.

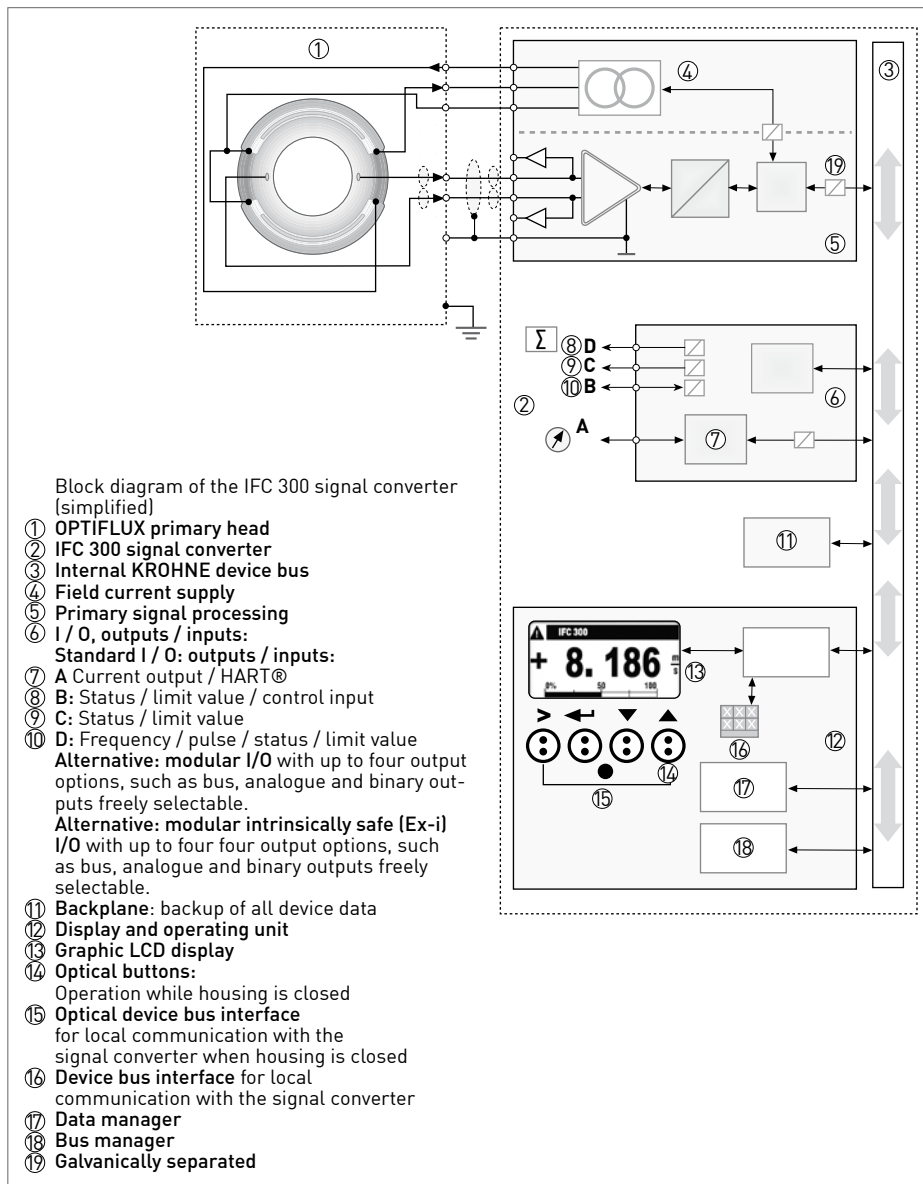

Fig. 65: Block diagram of an EMF signal converter (KROHNE, IFC 300)

The central communication of the signal converter is the internal device bus. Supported by bus and data managers, it connects the functional units and communicates settings, calibration data, measurement and diagnostic values, etc. All of the data can also be called up, recorded and set online via the two device bus interfaces.

The microprocessor (μP) of the primary signal processing system controls the switching of the field current supply. It supplies the field coils of the primary head with an active, periodically pulsed dc current.

The signal voltage induced in the process liquid and the voltages generated through diagnostic functions are transferred via a shielded signal cable from the electrodes of the primary head to the input amplifier in the signal processing system. This instrumentation amplifier with extremely high-impedance inputs amplifies the electrode voltage and supplies it to the A/D converter. This converter then samples the electrode voltage synchronously to the field cycle and converts it into digital values.

The μP filters the measurement and diagnostic values and scales them based on the calibration data which, like all other settings, is also stored on a backplane.

The device bus transfers all of the measurement and diagnostic data to the display on the operating unit as well as to the selected outputs of the I/O unit.

The display and operating unit also serves to set the measuring ranges as well as measuring and diagnostic functions in other areas. Settings can be made using the menu and optical keys or with a PC and adaptor via the device bus interfaces or via HART® and fieldbus systems. During operation, the graphics display indicates measuring and diagnostic data as well as totaliser values.

Due to its modular design, the I/O unit allows for simple integration into operational infrastructures through flexible selectable features and functions of the inputs and outputs down to bus interfaces and intrinsically safe Ex-i outputs.

8.5. Flow profiles

Section 7.3 covered the laminar and turbulent flow profile for Newtonian fluids with constant viscosity in an undisturbed pattern. However, additional or different conditions often occur in actual plants.

Due to space constraints, electromagnetic flowmeters must sometimes be installed with inlet runs that are too short. In some cases, EMFs must also be used downstream of gate or slide valves which is not advisable for a variety of reasons, see Section 5.3.

But no user would want to use an EMF with a nominal size of DN 1000 or larger if the faulty installation of that EMF would only be noticed some time after starting up the system and where, to that point, everything seemed to be running smoothly.

Reducers offer a way around this where the inlet run recommended by the manufacturer cannot be complied with. Fig. 66 shows the effect of an integrated reducer as used with a KROHNE OPTIFLUX 5000. The figure shows LDV measurements in an earlier EMF installed at a distance of $5 \times D$ downstream of the gate valve.

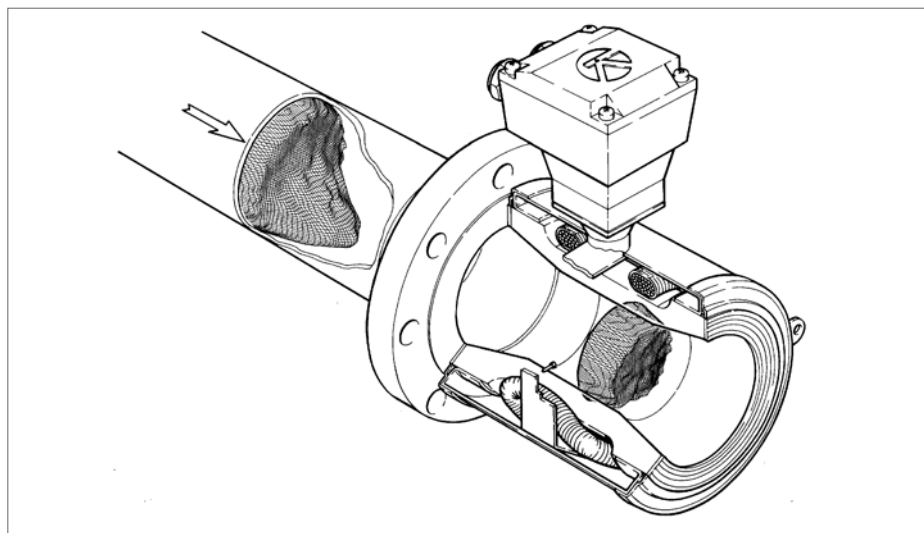

Fig. 66: Smoothing the flow profile by reducing the measuring cross section (PTB Berlin, 1991)

Below are a few examples of situations where distorted flow profiles occur.

Flow profiles downstream of partially opened gate valves

The flow profile of the process liquid can be severely distorted by a partially open valve.

As early as 1980, the SIREP WIB took profile influence measurements of EMFs

with a nominal size of DN 500 downstream of a partially open valve. It was installed at a distance of just one tube diameter (i.e. 500 mm) upstream of the inlet flange and then at a distance of five diameters (i.e. 5xDN or 2500 mm) downstream of the EMF. The results are shown in Fig. 67.

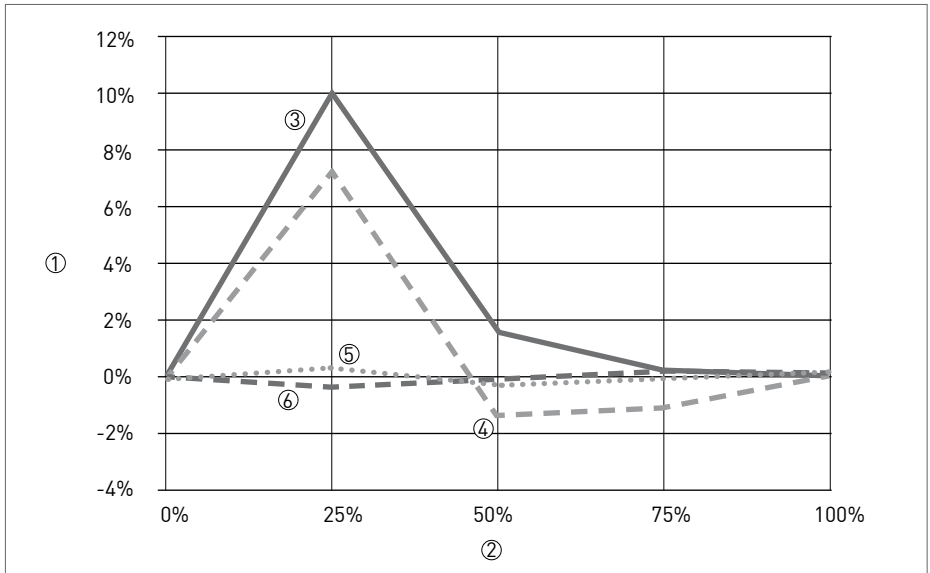

Fig. 67: Measurement errors downstream of a partially open valve in inlet runs of 1D and 5D

- ① Measurement error [% of measured value]
- ② Valve opening [%]
- ③ Valve 1D upstream of EMF flange, valve axis at 45° to electrode axis
- ④ Valve 1D upstream of EMF flange, valve axis perpendicular
- ⑤ Valve 5D upstream of EMF flange, valve axis perpendicular
- ⑥ Valve 5D upstream of EMF flange, valve axis at 45° to electrode axis

Here it can be clearly seen that the valve must be at least $5xDN$ away from the inlet flange so that the measurement remains accurate even when there is intense flow restriction through the valve.

In 1991, PTB Berlin conducted a test in cooperation with KROHNE to show how well a flow profile distorted by a partially open valve can be smoothed by a reducer (see Fig. 66). The following test conditions applied:

- Water at $20^{\circ}C$, DN 100, $85 \text{ m}^3/h$ ($v = 3 \text{ m/s}$);
- 1st Flow profile measurement $3xDN$ downstream of 25% open valve;
- 2nd Flow profile measurement $5xDN$ downstream of this valve in the measuring cross section of the EMF with a reduction from DN 100 to DN 80

Table 14 documents the smoothing effect of a reducer on the flow profile using laser Doppler measurements. In this test, the peak velocity v_{max} at the nose of the profile downstream of a valve was some 200% higher than the mean velocity v . The extreme values of the flow velocity in the reduced measuring cross section of the EMF deviate only approx. $\pm 4\%$ from the mean value. This corresponds to smoothing by a factor of approx. 50. For this reason, KROHNE recommends installing an EMF in a reducer whenever there is not enough space for the specified unimpeded straight inlet run, which must be equal to about five times the nominal size.

Flow velocity	Measurement at a distance of $3xDN$ downstream of the gate	Measurement within the reducer of the EMF
Mean value v	3.01 m/s	4.71 m/s
Peak value v_{max}	9.50 m/s	4.90 m/s
v_{max}/v	3.15	1.04

Table 14: Smoothing effect of a reducer (KROHNE, OPTIFLUX 5000)

Flow profiles downstream of elbows and expanders

Distorted flow profiles also occur after elbows. For this reason, an unimpeded inlet run of approximately five times the nominal size is recommended for EMFs. The measurement error caused by the elbow is then less than 0.2% of the measured value (see Section 3.1, Fig. 14).

The situation becomes more problematic after a sudden tube expansion. Here, the distorted flow profile features an increased peak flow in the middle of the tube which is caused by the reverse flow near the tube wall. When the distance to the expansion is greater, the reverse flow near the tube wall disappears but the "long nose" of the profile remains as a whole over longer sections.

This problem leads to noticeable EMF measurement errors and is the main reason why EMFs should not be installed downstream of expansions and that the EMF should never be larger than the nominal size of the pipeline.

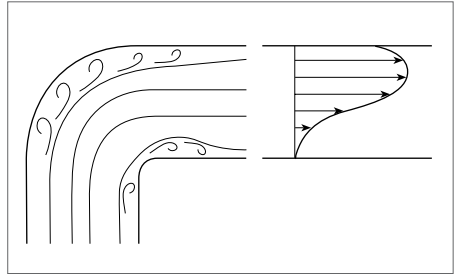

Fig. 68: Distorted flow profile downstream of an elbow

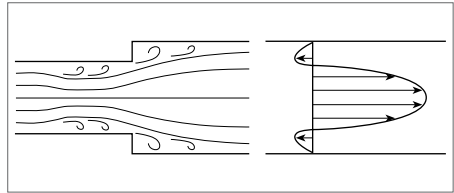

Fig. 69: Distorted flow profile downstream of a sudden expansion

Additional reasons include the low pressure in an expanded tube as well as the eddy shedding at the edge. Both these factors increase the risk of outgassing and unsteady EMF readings. But the distorted flow profile alone is enough to noticeably affect the measuring accuracy of the EMF installed downstream of a tube expansion.

Annular orifices have an effect on the flow profile similar to that of a sudden expansion in the diameter upstream of the EMF.

This is an opportune time to refer once again to the diagnostic capabilities of the OPTIFLUX IFC 300 signal converter from KROHNE. The integrated flow profile test shows whether and how severely the profile in the measuring tube is distorted. At the touch of a button, the display indicates whether installation was done properly or if, for example, a gasket is offset and thus protruding into the flow. The integrated diagnostic functions of the IFC 300 signal converter play a role in localising such causes of errors quickly and without interfering in the process, resulting in accurate and efficient troubleshooting.

Flow profiles during swirl flow

A swirl flow is an additional tangential velocity component in a tube flow. It is usually caused by several subsequent changes in direction in a pipeline. **Fig. 70** illustrates a well-known example of an out-of-plane double bend (i.e. more than one elbow on different planes).

In practice, swirling occurs in all pipelines in which two or more fittings such as pumps, throttled actuators, elbows, T-pieces, etc. cause a change in the direction of flow. Spiral welded pipes in

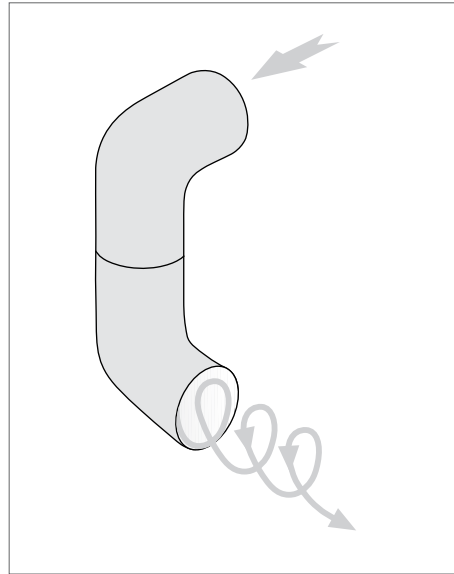

Fig. 70: Swirl flow caused by an out-of-plane double bend

which the welded seams protrude to the inside can also cause a swirl flow.

A swirl flow dissipates very slowly. Depending on the diameter of the tube, the flow velocity and the liquid parameters, dissipation may require a section that is approx. 50 to 150 times the nominal size of the pipeline. The larger the nominal size of the pipe and the flow velocity, the greater the probability of a swirl flow occurring. The accuracy of EMFs is not as severely impacted by swirl flows as is generally assumed (see **Section 3.1, Fig. 14**).

However, a swirl flow may be extremely disruptive if the medium is inhomogeneous, in other words if it consists of two components not completely mixed or cured. In this case, first one and then the other component swirls periodically past one and then past the other measuring electrode, generating considerable spikes in the electrochemical voltage. This situation can be seen in the periodic fluctuations in the flow display. A static mixer may be helpful in such cases.

The most effective way to reduce swirling is to use flow straighteners. When it comes to swirling, honeycomb straighteners are generally recommended.

Flow profiles for non-Newtonian fluids:

There are fluids whose viscosity is not constant. Instead, it changes in relation to the shear strain or the local velocity distribution and the duration and previous history of the mechanical load. Such fluids are referred to as "non-Newtonian fluids" and they include a number of fluids whose flow is measured by EMFs. Examples include:

- Activated sludge in wastewater;
- Tomato ketchup, toothpaste, liquid soaps (soft soaps);
- Mortar, cement sludge, latex paint;
- Pulp suspensions, fillers (e.g. kaolin) and coating material in the paper industry.

One exceptional example can be found in kaolin suspensions with a large portion of finely ground kaolin particles. These suspensions cause flow profiles with very low flow velocity near the EMF electrodes and thus significant measurement errors.

Nowadays, it is usually Coriolis mass flowmeters such as the OPTIMASS series from KROHNE that are successfully used for these shear thickening fluids.

Non-Newtonian fluids feature a fluctuating but very high viscosity. So, once gas or air has entered the fluid, it is very difficult for it to escape. As a result, the risk of faulty flow indicator values due to the amount of gas is very high. This risk can only be counteracted through relevant methods when filling and transferring, when mixing and by adding additives.

If fluids have a tendency to outgas, this must be prevented using measures such as high pressure, smooth and step-free pipe transitions well before the measuring station.

When selecting an electromagnetic flowmeter and during subsequent operation, it is generally not known whether swirl is present, whether the profile is distorted or whether there is enough space for an unimpeded inlet run. Unfortunately, EMFs are often incorrectly installed, downstream and too close to. Other than a very few exceptions, they still usually function well when it comes to the accuracy and reliability required in normal industrial applications.

8.6. Empty pipe detection

When the measuring tube of a mechanical flowmeter is empty, its flow indicator indicates the value "0" and flow totalising stops.

This is not the case with an EMF. The electrodes are no longer in contact with the process liquid and are open. The electrode circuit has an extremely high impedance when the tube is empty. Electrical interferences and couplings from the surroundings can then lead to error flow readings and totalised values. This is another reason why the installation site of an EMF must generally be selected so that the measuring tube is always completely filled with the process liquid, even when the flowrate is "zero", refer to **Section 5.3**.

If the EMF measuring tube is still empty, the flow outputs and indicator as well as volume totalising via functions such as empty pipe detection, empty pipe shut off and full pipe detection must be set to zero to avoid errors.

The following methods are common:

- Empty pipe detection via the measuring electrodes;
- Full tube detection via a full tube electrode;
- Full tube detection via the flow profile test;
- Empty pipe shut off via external control signals.

Empty pipe detection via the measuring electrodes and the electrode resistance

When the measuring tube is completely filled, the measuring electrodes are connected to each other and against the reference point of the EMF via the process liquid.

The resistance between the measuring electrodes or from one electrode to a reference point is a factor of the conductivity of the process liquid. This resistance is lower with a completely filled measuring tube than with an empty measuring tube. So, if the resistance is low, the empty pipe detection indicates: "pipe filled" and when the resistance is high it indicates "pipe empty".

The switching point must be set in such a way that even at the lowest conductivity occurring in the process, in other words at the highest occurring resistance with a full pipe, the message "pipe filled" is definitely indicated. Otherwise, the signal converter may indicate "pipe empty" when the measuring tube is still filled and then wrongly set the outputs and the display to "0" and stop the totalising. For this reason, proceed with caution when setting this option to avoid incorrect messages.

The advantage of this method is that no additional hardware expense is necessary for the primary head.

The disadvantage, however, is that the switching process only takes place when the liquid level drops below the electrode axis. Therefore, when the measuring tube becomes coated, this method no longer functions reliably. It also becomes problematic with vertical and long pipelines in which the process liquid runs down the tube walls for an extended period of time.

Full pipe detection via a full pipe electrode

This additional electrode is attached in the top of the measuring tube. When the EMF is installed in a horizontal pipeline, this electrode indicates partial filling even if the process liquid level decreases only slightly. Here too, the switching point must be set below the lowest electrical conductivity that can occur in the process.

The advantage of an additional full pipe electrode is the early indication of a partially filled measuring tube.

When filling or emptying the pipeline, large volumes of the process liquid are not measured and totalised before the pipeline has been fully filled or emptied again. In addition, the full pipe electrode does not respond at all or only very slowly in the case of highly viscous process liquids, incrustations and coatings sludge. The full pipe electrode indicates "pipe not full" even if only minimal gas content has collected at the top of the tube.

In the case of long, vertical pipelines in which the process liquid runs down the pipe walls for an extended period

of time even when the pipe is empty, the full pipe detection function may still indicate "pipe filled".

Full pipe detection via the flow profile test

When a pipeline is partially filled, the flow profile is asymmetrical. There is less process liquid flowing in the upper part of the measuring tube than in the lower part.

The KROHNE IFC 300 signal converter can monitor the measuring tube for complete filling using its diagnostic function "flow profile test", regardless of electrical conductivity, viscosity and incrustations. Generally, the flow profile test only responds when the liquid level has sunk below a value of approx. 75%. The empty pipe detector must then be activated as well.

Empty pipe shutoff via external control signals

This is the simplest and most reliable method of empty pipe shutoff. It uses information and control signals for pumps and valves which exist in most plants.

Almost all EMF signal converters feature binary control inputs. This allows the outputs to be set to "0" and the counter to be stopped. Only the control signals of the pumps or valves must be applied to the control input of the signal converter.

This method is simple and reasonable. In addition, the empty pipe shutoff is guaranteed regardless of the process liquid properties such as conductivity, viscosity and contamination in the measuring tube.

However, there is the risk that any volume that comes after the pumps have been switched off, or while the valve was closed, may not be measured. In addition, the empty pipe detection must be slightly delayed in relation to the starting of the pump and opening of the valve so that the pipeline is sufficiently filled before measurement can start again.

8.7. Grounding

Section 5.4 alluded to the fact that there is more than one possible method to ensure equipotential bonding between the process liquid and the reference potential of the signal processing in the signal converter. Section 8.7.1 covers the classical grounding methods used to achieve equipotential bonding by grounding the process liquid. Newer methods to achieve equipotential bonding without having to ground the process liquid are introduced in Section 8.7.2.

8.7.1. Classical grounding methods – grounding the process liquid

Classical methods for grounding the process liquid include

- Grounding in pipelines that are electrically conductive inside;
- Grounding using grounding rings or discs;
- Grounding using a grounding electrode.

The classical grounding methods are described below.

Grounding the process liquid in a pipeline that is electrically conductive inside

In pipelines that are electrically conduc-

tive inside, e.g. in the case of non-coated steel or stainless steel electrodes, the fluid in the tube always has the same potential as the grounded pipeline. The signal voltage at the electrodes thus has a fixed reference potential. Fig. 71 illustrates the simplest case for grounding the process liquid.

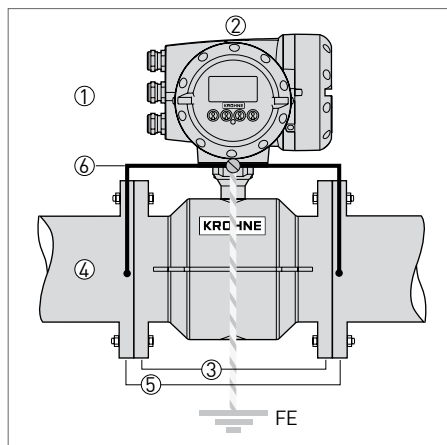

Fig. 71: Grounding the process liquid in metal pipelines not coated on the inside

- ① Primary head
 - ② Terminal box or signal converter
 - ③ Flowmeter flanges
 - ④ Pipeline
 - ⑤ Flange of the pipeline flowmeter
 - ⑥ Interconnecting cables
- FE Functional ground

Grounding the process liquid using grounding rings

In pipelines made of plastic or concrete or those which have an insulating lining or coating inside, additional measures must first be used to bring the process

liquid to a known fixed potential. To do this, metal grounding rings or grounding discs where the inside face is in contact with the process liquid are usually used. These grounding rings are generally fitted between the pipeline and the EMF flanges. Then, they are grounded along with the EMF sensor, as shown in Fig. 72.

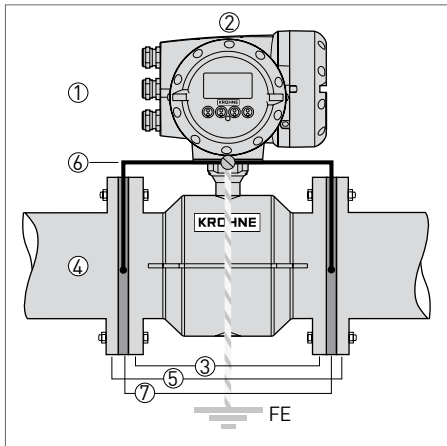

Fig. 72: Grounding the process liquid in pipelines with electrically insulated walls

- ① Primary head
- ② Terminal box or signal converter
- ③ Flowmeter flanges
- ④ Pipeline
- ⑤ Flange of the pipeline flowmeter
- ⑥ Interconnecting wires
- ⑦ Grounding rings
- FE Functional ground

This method is technically reliable and has been successfully used for decades.

The disadvantage to this method is that costs are higher, for example, if special materials are required for aggressive process liquids or when grounding rings for extremely large sizes must be used. With larger potential differences between the process liquid and earth in a system, equalising currents run via the grounding rings and earthing conductor.

Grounding the process liquid using a grounding electrode

In this case, a grounding electrode located in the base of the tube is directly connected to the grounded housing of the primary head.

The advantage of this method is that the grounding electrode generally costs less than the grounding ring.

However, it is particularly disadvantageous when there are differences in potential in the system of more than 0.2 Volt, as the grounding electrodes can be irreparably damaged by electrolytic action. In addition, abrasive solids in a horizontal pipeline can quickly destroy these grounding electrodes on the base at the tube. In both cases, complete

destruction of the EMF primary head is to be expected. In some circumstances, the process liquid may even leak out.

8.7.2. Newer grounding methods without grounding the process liquid

Newer methods for grounding process liquids include

- Floating grounding electrode to transfer the reference potential of the process liquid;
- Virtual grounding.

These newer grounding methods are described below. Of particular note is the virtual grounding method developed by KROHNE.

Floating grounding electrode

With this method, the grounding electrode in the base of the tube is no longer in direct contact with the grounded housing on the functional grounding of the primary head. In this case, a floating electrode transfers the potential of the process liquid as reference potential to a high-impedance input at the signal converter. No measurable current runs through the floating reference electrode.

The crucial advantage of this method over the classical grounding electrode is that the reference electrode is no longer exposed to electrolytic destruction by way of potential differences in the system. In addition, with this method it is also possible to use ungrounded EMFs in systems where voltages and currents are present in the pipelines. This is the case with, for example, electrolysis and electroplating plants and systems with cathodic protection.

Virtual grounding

The term "virtual grounding" may sound like this patented method does not really involve grounding. That is why the more technically precise term of "virtual reference" is often used. Problems with the conventional grounding of EMFs are what triggered the development of virtual grounding by KROHNE. These problems can be summarised as follows:

- When it comes to extremely aggressive fluids, the grounding rings used with conventional methods must usually be manufactured using expensive special materials.
- In extreme cases, such as grounding rings made of tantalum, costs may equal those of the EMF itself.

- Grounding electrodes, the low-cost alternative to grounding rings, can be destroyed through electrolytic action in the face of minimal differences in potential of e.g. only 0.2 Volt in the system.
- In systems with cathodic protection the risk is that the cathodic protection will be impacted via the grounding methods on the EMF. This applies analogously to electrolysis systems.

KROHNE developed a simple, cost-effective solution for this. "Virtual reference" or "virtual grounding" can be done without the use of grounding rings or grounding electrodes, as shown in Fig. 73.

In the case of virtual grounding, the primary head of the EMF is built into pipelines with electrically insulated walls, without grounding rings or grounding electrodes. The measuring electrodes are then the only metallic elements of the EMF left in contact with the process liquid.

The input amplifier of the IFC 300 signal converter measures the potential of the EMF measuring electrodes and, using a method patented by KROHNE, generates a voltage that corresponds to the potential of the ungrounded process liquid. This voltage is then used as a reference potential for signal processing. Thus, during signal processing there is no longer a disruptive potential difference between the reference potential and the voltage at the measuring electrodes.

The use of virtual grounding boasts several advantages over classical grounding.

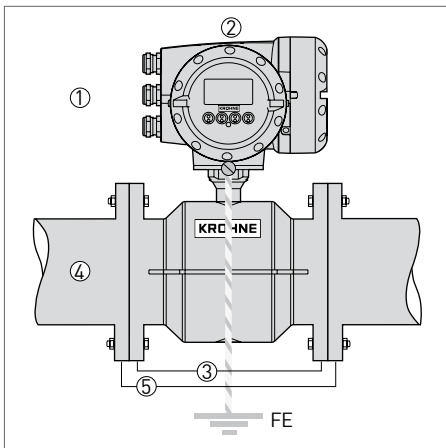

Fig. 73: Virtual grounding via the device electronics when installing the EMF in pipelines with insulated walls

- ① Primary head
 - ② Terminal box or signal converter
 - ③ Flowmeter flanges
 - ④ Pipeline
 - ⑤ Flange of the pipeline flowmeter
- FE Functional ground

For one thing, virtual grounding eliminates the need for additional wetted grounding equipment such as grounding rings and grounding electrodes. This results in lower costs and an EMF that is much easier to install. This advantage is not to be undervalued. It is often faulty or a lack of grounding altogether that is the cause of errors when starting up EMFs.

In addition, potential differences in systems with virtual grounding do not run the risk of destruction due to electrolytic action, as is often the case with grounding electrodes. No equalising current runs through process liquid and ground conductor.

EMFs with virtual grounding can also be used in systems in which voltages and currents are present in the pipeline, as with, for example, electrolysis and galvanic plants. Otherwise, due to the highly aggressive media, special materials such as tantalum, nickel or titanium must be used for the grounding rings or grounding electrodes in such systems. Grounding rings made of these special materials result in considerably higher costs for the measuring system.

So, getting rid of grounding rings completely and instead using EMFs with virtual grounding is the most economical solution in this case.

EMFs with virtual grounding can also be installed ungrounded in systems with cathodic protection, without running the risk of degrading the cathodic protection through error currents.

Virtual grounding facilitates and makes installing an EMF cheaper. The need for additional gaskets between grounding rings and flanges, as required with the classic installation using grounding rings, is eliminated. The risk of leakage is also smaller.

As a general rule, virtual grounding is possible starting at DN 10 and at a conductivity of more than 200 $\mu\text{S}/\text{cm}$. The conductivity of aggressive process liquids such as inorganic acids and caustics is exponentially higher.

EMFs with virtual grounding in the KROHNE IFC 300 signal converter can be used in almost all systems in which classical grounding with grounding rings is problematic in terms of the technology or cost.

A brief recap of the advantages of virtual grounding:

- **Low cost:**
No grounding rings or grounding electrodes required. Costs are thus lower.
- **No equalising currents:**
The reference potential is generated in the IFC 300 signal converter and is insulated against earth. No current runs through the pipeline, the process liquid or the earth. There is thus no equalising current in electrolysis or galvanic systems and no stress on the cathodic protection.
- **No additional risk of leakage:**
Grounding rings with additional sealing points or grounding electrodes which run the risk of destruction through electrolytic action are not necessary.

8.8. Surge Protection

Measures to protect against surges in voltage are recommended when using EMFs in regions at risk of electrical storms. This is particularly applicable when EMFs are installed outdoors and where the line and input/output cables are wired to system components exhibiting a different grounding potential such as with underground pipelines or sewage treatment plants.

The primary head of an EMF, or more precisely, its housing, its electrode circuit and the functional earth are at the same potential as the functional earth of the pipeline. The housings of the signal converters are usually connected to the power supply protective earth. Due to the galvanic separation, there is no electrical connection between the functional and the protective earth in the signal converter. The same is true for the signal converter outputs. Test voltages for these galvanic separations are usually between 0.5 kV and 1.5 kV. In the event of a lightning strike, however, considerably higher voltage differences may occur between the functional and protective earths, which could destroy the affected devices and subsequent

instruments if appropriate additional protective measures are not taken.

In the case of EMFs, the best primary protection against surges in voltage is the proper grounding of the pipeline, primary head and signal converter to a single point. Protective methods and elements may vary according to the EMF manufacturer, type, installation site and the number of inputs and outputs used.

As seen in the following examples, KROHNE offers fully installed equipment to meet a wide variety of requirements when it comes to surge protection. Surge protectors specific to your requirements for all of the cables and system components to be protected are selected.

For compact EMFs and remote versions where the signal converter is installed in close proximity to the primary head, the following measures are sufficient:

- Proper grounding near the primary head (safety PE quality when the power supply is more than 60 V);
- Do not apply PE from power supply cable to signal converter;
- For remote version EMFs, connect the protective earth connection of the signal converter housing to the earth of the primary head;
- Provide surge protection for all wires on the input and outputs of the signal converter;
- Surge protection also for L/N of power supply (not shown here);
- Provide equipment for reliable surge protection in close proximity to the EMF.

For larger systems, advice from a professional service is recommended. **Fig. 74** shows an example of voltage surge protection measures for the KROHNE OPTIFLUX 2300C with integral signal converter and with non-coated pipelines. For pipelines with insulated walls, the additional appropriate grounding methods as presented in **Section 8.7.2** are to be used.

If, in the case of remote version EMFs, the signal converter is installed some distance from the primary head, signal and field current cables as well as all connecting cables must be included in the surge protection. When the distance between the primary head and the signal

converter is great, the following additional measures must be taken:

- Protect all of the wires for the signal and field current cables;
- Surge protective devices can influence the measuring accuracy and should be discussed with the manufacturer;
- The protective devices should be installed as close as possible to the signal converter in the same cabinet or shaft.

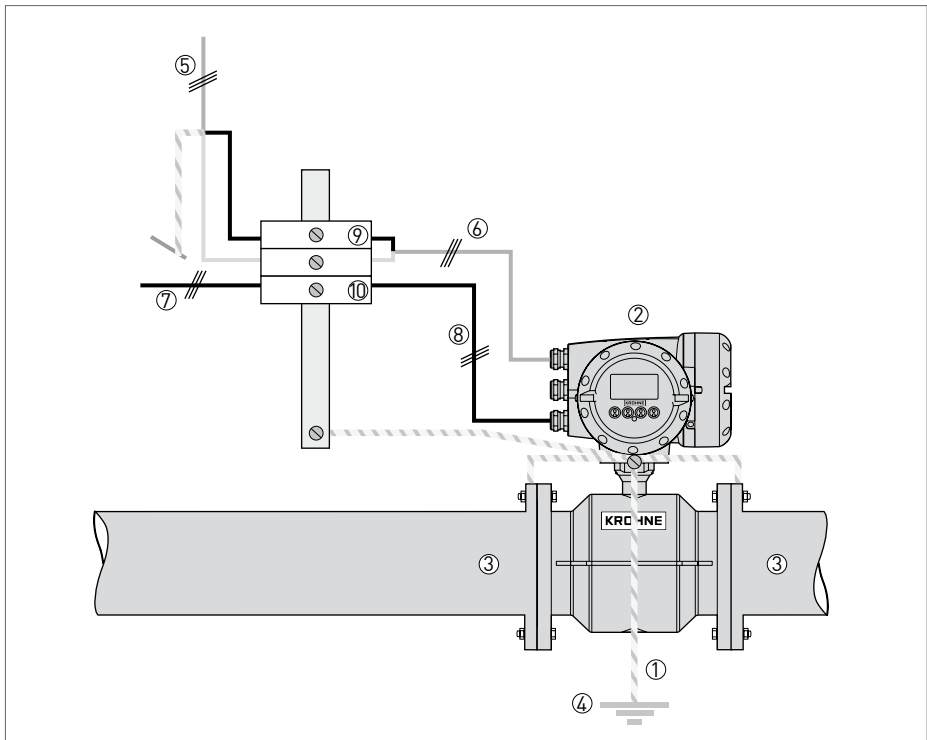

Fig. 74: Surge Protection in a compact EMF version

- ① EMF primary head
- ② EMF signal converter
- ③ Pipeline
- ④ Lightning protection earth and protective earth (PE or FE)

- ⑤ Power supply feed (disconnect PE!)
- ⑥ Protected power supply line
- ⑦ EMF signal output
- ⑧ Protected signal output line
- ⑨ Surge Protection for power supply
- ⑩ Surge Protection for signal output of the EMF

Fig. 75 shows an example of surge protection measures using the remote version of KROHNE's OPTIFLUX 2300W with pipelines with non-coated inside walls.

For pipelines with insulated walls, the appropriate grounding methods outlined in Section 8.7.2 are to be used.

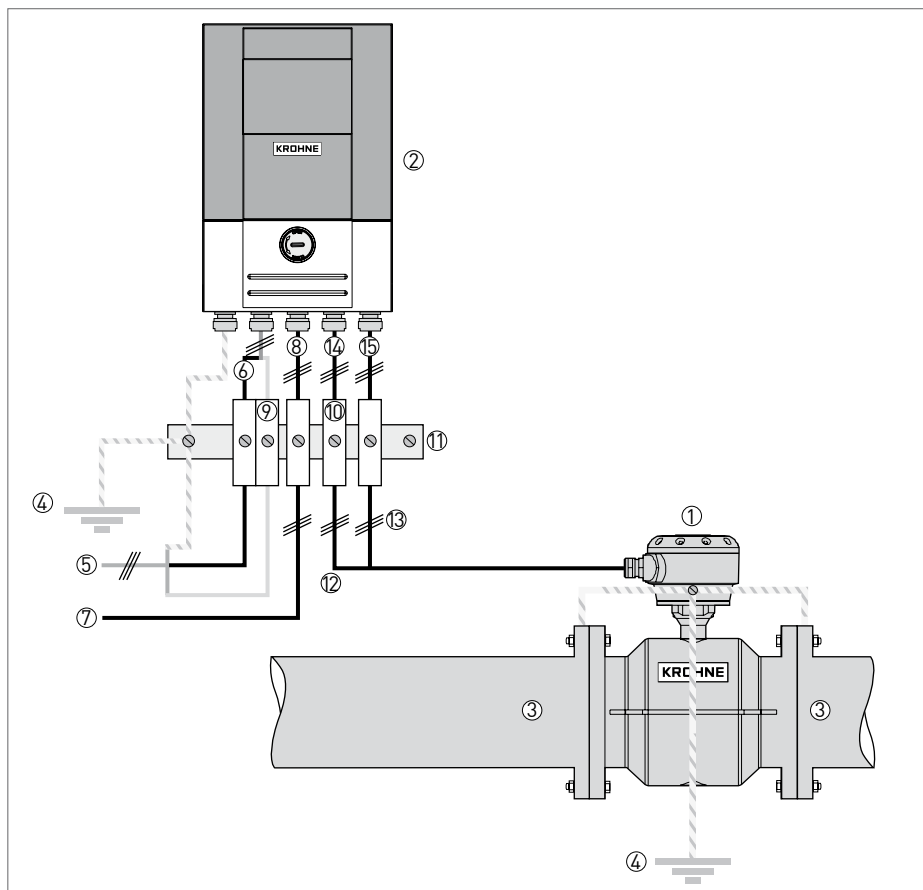

Fig. 75: Surge protection in a remote system EMF version

- ① EMF primary head
- ② EMF signal converter
- ③ Pipeline
- ④ Lightning protection earth and protective earth (PE and FE)
- ⑤ Power supply line
- ⑥ Protected power supply line

- ⑦ Signal output line
- ⑧ Protected signal output line
- ⑨ Surge protection for power supply
- ⑩ Surge protection elements for signal inputs and outputs of the EMF and field current
- ⑪ Assembly rail for the protective elements
- ⑫ Field current cable
- ⑬ Electrode signal cable
- ⑭ Protected field current cable
- ⑮ Protected electrode signal cable

8.9. Norms and standards

This is a list of only the most important European standards applicable to electromagnetic flowmeters and no claim is made as to the completeness of the list.

Specific standards for electromagnetic flowmeters

- EN 29104:1993 (ISO 9104:1991)
Measurement of fluid flow in closed conduits;
Method for assessing the operating performance of electromagnetic flowmeters for liquids;
Substitute for: DIN 19200:1989-01.
- DIN EN ISO 6817:1995
Measurement of conductive liquid flow in closed conduits;
Method with electromagnetic flowmeters.
- DIN ISO 13359:1998-09
Measurement of conductive liquid flow in closed conduits;
Electromagnetic flowmeters with flanges;
Installation lengths
(identical to DVGW W 420).
- VDI/VDE 2641 (no longer valid, withdrawn 2000-01);
Electromagnetic flow measurement.
- VDI/VDE 2641 Sheet 2 (no longer valid, withdrawn 1996-11);
Electromagnetic flow measurement;
Installation lengths and flange connection dimensions of flowmeters with flanges;
Instead, the following is recommended
DIN ISO 13359(1995-11).

Flange standards

- DIN EN 1092: Flanges and their connections.

General CE guidelines

- Pressure Equipment Directive 97/23/EC;
- Low Voltage Directive 2006/95/EC. 5. 3.;
- EMC Directive 2004/108/EC;
- Machinery Directive 2006/42/EC.

Directives for use in hazardous areas

- Directive 94/9/EC (ATEX 100)

SIL (safety integrity level)

- DIN EN/IEC 61508 / IEC 61511

Housing protection categories (IP and other types of protection)

- DIN 40050, depending on area of use also DIN 40050-9;
- DIN EN 60529 or IEC publication 529;
- NEMA Standard 250 -2003 (USA);
- UL 50 (USA);
- CSA-C22.2 No. 94-M91 (2006) (Canada).

Directives for custody transfer

- Measurement Instruments Directive 2004/22/EC;
International metrological recommendations such as:
 - OIML R49-1
(for both cold and hot water);

- OIML R117
(DIN 19217 Measuring systems for liquids other than water);
- OIML R75
Measuring thermal energy.

Guidelines for surge protection

- DIN VDE 0100-443;
- DIN EN 62305 and VDE 0185-305:
These standards regarding lightning protection provide information on all aspects from "General objectives" to "Risk management" right down to "Electrical and electronic systems in structural plants" and also contain supplementary sheets covering such content as "Lightning threat in Germany".

VDI/VDE directives

- VDI/VDE 2650:
Requirements regarding self-monitoring and diagnosis in field instrumentation.

NAMUR guidelines

NAMUR is an international association of automation technology users in the process industry. NAMUR issues recommendations and working sheets.

NAMUR Worksheets ("NA") provide assistance in the form of checklists and instructions to support member companies in their practical work.

NAMUR Recommendations ("NE") explain the state of the art and the regulations, not only for member companies but also for manufacturers, scientists and public authorities.

Below is a selection of NAMUR worksheets and recommendations prepared specifically for electromagnetic flowmeters or that are applicable to field devices in general.

- NA 101 (25.10.04):
The Calibration Requirements "in brief" for Flow Measuring Equipment
- NE 021 (22.08.07):
Electromagnetic Compatibility (EMC) of Industrial Process and Laboratory Control Equipment
- NE 032 (08.01.03):
Data Retention in the Event of a Power Failure in Field and Control Instruments with Microprocessors
- NE 043 (03.02.03):
Standardization of the Signal Level for the Failure Information of Digital Transmitters
- NE 053 (04.02.03):
Software of Field Devices and Signal Processing Devices with Digital Electronics
- NE 070 (26.01.06):
Electromagnetic Flowmeters (EMF)
- NE 080 (14.04.03):
The Application of the Pressure Equipment Directive to Process Control Devices
- NE 107 (12.06.06):
Self-Monitoring and Diagnosis of Field Devices
- NE 131 (29.04.09):
NAMUR Standard Device – Field Device Requirements for standard applications

9. Summary and outlook

In 2009, there were more than 3 million EMFs in use around the world. EMFs play an important role, from water supply to the food and beverage industry right down to wastewater treatment. The pipelines and sewer pipes of some mega-cities feature EMFs up to 3000 mm in size, measuring and totalising up to 100,000 m³/h.

In steel mills, more than 100 EMFs monitor the cooling water circuits to furnaces and in strong magnetic fields to electric furnaces.

Large chemical factories run several thousand EMFs around the clock. They measure hot concentrated inorganic acids and caustics and are responsible for mixing many products in the proper proportions.

In every pulp and paper factory, many EMFs ensure that paper is produced in an environmentally friendly manner, in high quality and in sufficient quantity. One large paper machine alone uses up to 200 EMFs.

The wide range of use, high accuracy and reliability of EMFs was made possible by progress in a wide range of areas in technology.

One of these areas is, for example, coating materials. The successful progress of EMFs in the chemical and food and beverage industries started when fluoroplastics like PTFE and later PFA became available at reasonable prices. Only when measuring tubes made of highly dense engineered ceramics with their appropriate stability became available could EMFs be used in calibration rigs and as flowmeters in volumetric filling machines.

Highly integrated switching circuits make the μ P signal converters extremely stable, user-friendly and provided them with a variety of functions and interfaces.

As with all measuring devices, KROHNE will continue to take advantage of all of the technical trends as well as set their own trends to constantly expand the range of application of EMFs.

- [1] **Appel, E. (1979):**
Neue Techniken der Induktiven Durchflußmessung.
In: VFI Der Versuchs- und Forschungsingenieur, No. 3, pp. 28–33.
- [2] **Appel, E. (1985):**
Induktiver Durchflußmesser mit keramischer Auskleidung und kapazitivem Signalabgriff.
In: Automatisierungstechnische Praxis, No. 4, pp. 199–200.
- [3] **Baker, R. C. (1970):**
Effects of non-uniform conductivity fluids in electromagnetic flowmeters.
In: Journal of Physics D: Applied Physics, No. 3, pp. 637–639.
- [4] **Baker, R. C. (1982):**
Electromagnetic Flowmeters.
In: Scott, R. W. W. (ed.): Developments in Flow Measurement – 1, Applied Science Publishers, London.
- [5] **Baker, R.C. (1985):**
Theorie und Praxis der elektromagnetischen Durchflußmessung.
In: Technisches Messen, Vol. 52, No. 1, pp. 4–12.
- [6] **Baker, R. C. (1985):**
The Effect on Electromagnetic Flowmeters of a Change in Fluid.
In: Measurement & Control, No. 18, pp. 5–10.
- [7] **Bekkum, J. V.; Warffemius, M. M.; Oldenziel, D. M. (1989):**
On The Hydrodynamical Stability of Electromagnetic Flowmeters.
In: Harbrink, B.; Spencer, E. A. (ed.): Flow Measurement FLO MEKO, VDI, pp. 143–150.
- [8] **Bevir, M. K. (1970):**
The Theory of Induced Voltage Electromagnetic Flowmeters.
In: Journal of Fluid Mechanics, No. 43, pp. 577–590.

[9] Bevir, M. K. (1972):

The effect of conducting pipe connections and surrounding liquid on the sensitivity of electromagnetic flowmeters.
In: Journal of Physics D: Applied Physics, No. 5, pp. 717–729.

[10] Bonfig, K. W. (1970):

Einflüsse auf die Nutzspannung bei der induktiven Durchflußmessung.
In: Archiv für technisches Messen, Lfg. 414, pp. 145–150.

[11] Bonfig, K. W. ; Hofmann, F. (1975):

Die Technik der magnetisch-induktiven Durchflussmessung.
In: Archiv für technisches Messen, Lfg. 473, No. 6.

[12] Bonfig, K. W., Feith, B. (1981):

Elektrochemische Störspannungen bei der magnetisch-induktiven Durchflußmessung in offenen Kanälen.
In: messen + prüfen/automatik, No. 1/2, pp. 36–39.

[13] Bonfig, K. W. (2002):

Überblick über die neueren Durchflussmessverfahren
In: Bonfig, K. W. (Hrsg.): Praxis der Durchflussmessung, Vol. 2, b-Quadrat Buchverlag, Kreuztal.

[14] Bonfig, K. W. (2002):

Magnetisch-induktive Durchflussmessung.
In: Bonfig, K. W. (Hrsg.): Praxis der Durchflussmessung, Vol. 2, b-Quadrat Buchverlag, Kreuztal.

[15] Brockhaus, H.; Klein, J. W.; van der Pol, R.; Schoth, U. (1997):

Kapazitiver magnetisch-induktiver Durchflussmesser unter Verwendung der Mikrosystemtechnik.
In: Sensoren und Sensorsignalverarbeitung, Vol. 8, p. 187.

[16] Brockhaus, H.

Magnetisch-induktive Durchflussmessung mit kapazitiven Verfahren
In: Technisches Messen, No. 64, p. 5.

- [17] Brockhaus, H. ; Klein, J. W.; van der Pol, R.; Schoth, U. (1997):
Kapazitive magnetisch-induktive Durchflussmessgeräte unter Verwendung der Mikrosystemtechnik.
In: Sensoren und Sensorsignalverarbeitung, Vol. 8, p. 187.
- [18] Brockhaus, H. (2000):
Magnetisch-induktiver Durchflussmesser, versorgt über die 4–20 mA-Schnittstelle.
In: Automatisierungstechnische Praxis, No. 11.
- [19] Brockhaus, H. (2002):
Möglichkeiten der Diagnose bei Durchflussmessgeräten.
In: Sensoren und Messdatenverarbeitung, Vol. 4.
- [20] Brockhaus, H.; Hofmann, F. (2002):
Magnetisch-induktiver Durchflussmesser als Zweileitergerät.
In: Sensoren und Messdatenverarbeitung , Vol. 4.
- [21] Brockhaus, H.; Hofmann, F. (2002):
Spezielle Anwendungen der magnetisch-induktiven Durchflussmessung.
In: Bonfig, K. W. (Hrsg.): Praxis der Durchflussmessung, Vol. 2, b-Quadrat Buchverlag, Kreuztal.
- [22] Engl, W. L. (1970):
Der induktive Durchflußmesser mit inhomogenem Magnetfeld.
Teil 1
In: Archiv für Elektrotechnik, No. 53, pp. 344–359,
- [23] Engl, W. L. (1972):
Der induktive Durchflußmesser mit inhomogenem Magnetfeld.
Teil 2
In: Archiv für Elektrotechnik, No. 54 , pp. 269–277.
- [24] Faraday, M. (1832):
Experimental Researches in Electricity.
In: Philosophical Transactions of the Royal Society, No. 15, p. 175.

[25] Hemp, J. (1975):

Improved magnetic field for an electromagnetic flowmeter with point electrodes.

In: Journal of Physics D: Applied Physics, No. 8, pp. 983–1002.

[26] Hofmann, F. (1978):

New Developments in Magnetic Flow Measurement using Keyed D.C. Field.

In: Dijstelbergen, H. H.; Spencer, E. A. (ed.): Flow Measurement of Fluids, North-Holland Publishing, pp. 499–502.

[27] Hofmann, F. (1978):

Magnetic Flowmeter with Capacitive Signal Pick-Off.

In: Dijstelbergen, H. H.; Spencer, E. A. (ed.): Flow Measurement of Fluids, North-Holland Publishing, pp. 493–497.

[28] Hofmann, F. (1993):

Magnetisch-induktiver Durchflussmesser mit strömungsoptimierendem Messrohr.

In: Chemietechnik, No. 5, p. 142f.

[29] Hofmann, F.; Oehler, G. (1997):

Magnetisch-induktiver Durchflussmesser zur Abfüllung kleiner Volumina.

In: Sensoren und Sensorsignalverarbeitung, Vol. 8, p. 180.

[30] Hofmann, F. (1999):

Volumetric Filling Using Electromagnetic Flowmeters.

In: drink technology & marketing, No. 9.

[31] Hofmann, F. (1999):

Magnetisch-induktive Durchflussmessung für teilgefüllte Rohrleitungen.

In: Wasser, Luft und Boden, No. 10.

[32] Hofmann, F. (2000):

Halbvoll und trotzdem genau gemessen.

In: MSR-Magazin, No. 5.

[33] Hofmann, F. (2000):

Magnetisch-induktive Durchflussmesser aus Edelstahl:
Für kompakte volumetrische Füllanlagen.
In: Deutsche Ernährungs-Industrie, No. 5.

[34] Hofmann, F. (2001):

Vier sind oft zwei zuviel: Moderne Durchflussmesstechnik mit zwei Leitern.
In: MSR Magazin, No. 3.

[35] Hofmann, F. (2004):

Magnetisch induktive Durchflussmesser (MID).
In: Früh, K. F.; Meier, U. (ed.):
Handbuch der Prozess automatisierung, 3rd edition,
Industrieverlag München, p. 419.

[36] Hofmann, F. (2004):

Der Messstoff bestimmt die Technik – Richtige Auswahl des Durchflussmessers drosselt die Folgekosten.
In: P&A, June 2004.

[37] Hofmann F. (2004):

Gleichfeld kontra Wechselfeld - Magnetisch-induktive Durchflussmessung von Schlämmen und Trüben.
In: P&A KOMPENDIUM, p. 140.

[38] Horner, B.; Mesch, F. (1995):

An induction flowmeter insensitive to asymmetric flow profiles. Process tomography – 1995 implementation for industrial processes.
In: ECAPT Meeting "European Concerted Action on Process Tomography", Bergen, Norway, pp. 321-330.

[39] Ketelsen, B.; Appel, E. (1975):

Die Meßunsicherheit induktiver Durchflußmesser mit inhomogenem Magnetfeld bei rotationsveränderten Strömungen – Teil I.
In: Regelungstechnische Praxis, No. 12, pp. 369-375.

[40] Ketelsen, B.; Appel, E. (1976):

Die Meßunsicherheit induktiver Durchflußmesser mit inhomoge-

nem Magnetfeld bei rotations-
veränderten Strömungen – Teil II.
In: Regelungstechnische Praxis,
No. 1, pp. 15–19.

[41] Kiene, W. (1976):

Magnetisch-induktive Durchfluß-
messer.

In: messen + prüfen/automatik,
No. 6, pp. 316–331.

[42] Kolin, A. (1936):

An electromagnetic flowmeter.

In: Proceedings of the Society for
Experimental Biology and Medi-
cine, Vol. 35, pp. 53–57.

[43] Kolin, A. (1945):

An Alternating Field Induction
Flow Meter of High Sensitivity.

In: Review of Scientific Instru-
ments, Vol. 16, p. 109.

[44] Ludwig, D. (2002):

Volumetrische Fülltechnik mit
Durchflussmessgeräten auf
magnetisch induktiver Basis.

In: VDI-Berichte 1652, Tagung
Langen, 4.3.2002, p. 31.

[45] Polly, P.; Reinhold, I. (1974):

Der Einfluss der Symmetrie-
Eigenschaften des Strömungs-
profiles beim induktiven Durch-
flussmessgeräten.

In: Archiv für technisches Mes-
sen, Lfg. 464, No. 9, pp. 153–158.

[46] Reinhold I. (1975):

Magnetfeldformung und Meß-
genauigkeit beim magnetisch-
induktiven Durchflußmessgerät.

In: Archiv für technisches Mes-
sen, Lfg. 476, No. 9, p. 139–144.

[47] Reinhold, I. (1978):

Velocity Profile Influence on
Electromagnetic Flowmeter
Accuracy.

In: Dijstelbergen, H. H.; Spencer,
E. A. (Hrsg.): Flow Measurement
of Fluids, North-Holland Publi-
shing, pp. 181–185.

[48] Schommartz, G. (1974):

Induktive Strömungsmessung.
VEB Verlag Technik, Berlin.

- [49] Shercliff, J. A. (1954):
Relation between the velocity profile and sensitivity of electromagnetic flowmeters.
In: Journal of Physics D: Applied Physics, Vol. 25, p. 817.
- [50] Shercliff, J.
The theory of electromagnetic flow-measurement.
In: Cambridge, University Press.
- [51] Stern, K. (2002):
Magnetisch-induktive Durchflussmesser (MID) im Einsatz für Abfüll- und Dosieraufgaben.
In: Bonfig, K. W. (Hrsg.): Praxis der Durchflussmessung, Vol. 2, b-Quadrat Buchverlag, Kreuztal.
- [52] Thürlemann, B. (1941):
Methode zur elektrischen Geschwindigkeitsmessung in Flüssigkeiten.
In: Helvetica Physicalica Acta, No. 14, pp. 383–419.
- [53] Timofeev, V. A.; Kirshtein, G. K. (1983):
Dependence of readings of electromagnetic flowmeters with two-coil magnet structures on velocity profile.
In: Magnetohydrodynamics, Vol. 19, No. 3, pp. 343–348.
- [54] Trächtler, A.; Horner, B.; Schupp, D. (1997):
Tomographische Methoden bei der induktiven Durchflussmessung zur Bestimmung von Strömungsprofilen und -parametern
In: Technisches Messen, No. 64, p. 10.

A

Abrasion	41, 65, 105
AC field	61, 150ff.
Acceleration energy	132
accuracy (error)	29, 40ff., 114, 124
ambient temperature	110, 122
aseptic EMF (hygienic)	32

B

back pressure (dynamic pressure)	132ff.
Batch process (volumetric filling)	83ff.
Battery powered	74ff.
Bernoulli's Law (Principle of Energy Conservation)	132
Bootstrap (shielding)	154ff.
Burn-in test	122
Bus (device bus)	157

C

cable (signal cable)	80, 86, 154ff.
calibration, calibration rig	124ff.
capacitive fill level measurement	73
capacitive signal pick-up (no-electrode EMF)	70
chemical resistance	105ff.
communication (interface)	29, 34, 86, 157ff.
compact EMF	109, 113, 176
conductivity, electrical	26, 35, 44, 70ff., 80ff., 97
continuity equation (Law of Flow)	131
corrosion	30, 44
counter (preselection counter)	22, 74, 130
Custody transfer	59ff.

D

device bus (bus)	157
diagnosis (test)	46ff.

Diameter (size, DN, nominal size)	31, 102ff.	empty measuring tube	50, 167ff.
DIN 19200	179	empty pipe detection	167ff.
Direction of flow	29, 43	EN 29104 (= ISO 9104)	124, 179
DN (size, diameter, nominal size)	31, 102ff.	EN standards	179
DVGW W420 (= ISO 13359)	79, 179	error (measurement error, measuring accuracy)	29, 40ff., 114, 124
Dynamic pressure (back pressure)	132ff.	error modes	48
Dynamic viscosity	134ff.	Ex-version, hazardous area, Explosion protection	55ff.
E			
Earth conductor	170ff.	F	
earthing	118, 170ff.	FE (Functional Earth)	170ff., 175ff.
Earthing electrodes	171ff.	field coils	30, 50, 157
earthing rings, earthing discs	170ff.	field current supply	74, 159
electrical conductivity (minimum)	26, 35, 44, 70ff., 80ff., 97	Filling, volumetric (batch process)	83ff.
Electrode material	107	flanged EMF	31, 104
Electrode voltage	150ff.	flooding (protection category)	108, 115
Electrodes	31, 107	Flow probes	91

Alphabetical index

flow profiles	42, 50, 67, 112, 134ff., 160ff., 169	IMoCom-Bus	157
flow rate (q)	22, 28, 130ff, 145.	Inlet/outlet runs	103, 112, 160ff.
flow resistance	138	inside diameter (of EMF and pipeline)	31, 102ff.
Flow velocity	27, 132ff.	installation site (of primary head and signal converter)	112ff.
flow velocity (v)	27, 103, 145	interface (communication)	29, 34, 86, 157ff.
fluid mechanics	130ff.	internal resistance (source impedance)	150, 154, 157,
Foundation	29, 34	ISO 13359 (= DVGW W420)	79, 179
Fieldbus (FF)		ISO 6817	179
four-wire EMF	80	ISO 9104 (= EN 29104)	124, 179
full pipe detection	167ff.	K	
full scale range (Q100%)	157	kinetic energy	133
functional earth FE	170ff., 175ff.	L	
G		Laminar flow	134
Gas content	98ff.	Law of Flow (continuity equation)	131
H		level measuring, capacitive	73
HART®	29, 34, 158		
heat sources and sun	116		
Hygienic EMF (aseptic)	32		
I			
IEC standards	180		

Lightning protection (overvoltage protection)	175	measuring principle	27, 144ff.
line (cable)	80, 86, 154ff.	measuring range	103
linear measuring principle	29, 40	minimum conductivity, electrical	26, 35, 44, 70ff., 80ff., 97
Liner	30, 50ff., 65ff., 105	mounting location (of primary head and signal converter)	112ff.
low flow cutoff (starting threshold)	43	multiwire EMF	79
M		N	
MagCheck	46	NAMUR	181
magnetic fields, external	47, 60ff.	Newtonian fluids	91, 160
mains voltage (power supply)	79, 115	No-electrode EMF (capacitive signal pick-up)	70
maintenance	44	nominal size (size, DN, diameter)	31, 102ff.
mass flow measurement	22, 64 130, 166	non-Newtonian fluids	165
measured ranges	22, 130	O	
measurement error (measuring accuracy, measuring error)	29, 40ff., 114, 124	OIML	78
measuring accuracy (measurement deviation, measuring error)	29, 40ff., 114, 124	P	
		partly filled pipes	72ff.
		PE (Protective Earth)	170ff., 175ff..

Alphabetical index

pipe friction coefficient	139	Protective Earth (PE)	
pipeline, partially filled	72	pulsating flow	170ff., 175ff
potential difference	118, 170ff.	Pulsed direct current (dc) field	62
Power supply (mains voltage)	79, 115	Q	
power surge protection (lightning protection)	175	$Q_{100\%}$ (full scale range)	157
preselection counter (counter)	22, 74, 130	R	
Pressure loss	137ff.	reduction (to a smaller nominal size)	103, 160
pressure ratings	31, 102	Remote version EMF	109, 115, 176
primary head	30ff., 112ff.	Resistance, chemical	105ff.
Principle (measuring principle)	27, 144ff.	Reynolds number Re	137
Principle of Energy Conservation (Bernoulli's Law)	132	S	
process liquid temperature	29, 47, 97, 106ff., 116	Sandwich EMF	32
PROFIBUS® interface	29, 34	Shielding (Bootstrap)	154ff.
protection category	108ff., 115, 180	signal cable (cable)	80, 86, 154ff.
		signal converter	38, 115ff., 157ff.
		Size (DN, nominal size, diameter)	31, 102ff.

solid particles	29, 64ff.	vibrations	45, 63, 110, 117
solids	64ff., 97	virtual earthing	172
source impedance (internal resistance)	150, 154, 157,	viscosity	43, 134ff.
Standard condition	22, 131	volume (flow)	22, 28, 130ff, 145
Standards	179	volume counting	22, 130
start-up threshold (low flow cutoff)	43	volumetric filling (batch process)	83ff.
static pressure	132ff.	W	
swirl flow	164	WIB-SIREP	42, 161
T			
temperature (process liquid temperature and ambient temperature)	29, 47, 97, 106, 110, 116, 122		
test (diagnosis)	46ff.		
testing equipment	46		
turbulent flow	136		
two-wire EMF	81ff.		
V			
vacuum	105, 113		
VDI / VDE	179ff.		