



Process instrumentation, Measurement solutions and Services

Overview

KROHNE

▶ measure the facts

ETA Process Instrumentation

www.etapii.com

sales@etapii.com

tel 978.532.1330

New England

Martech Controls

www.martechcontrols.com

sales@martechcontrols.com

tel: 315.876.9120

Upstate New York



KROHNE – your global partner

KROHNE is your reliable partner for process instrumentation and automation. As our client, you benefit from our ability to solve your applications with matching measurement solutions. We offer you a complete product portfolio, industry specific system solutions and complementary services for instrumentation projects of any size.

By having specialised in industrial process measurement since 1921, we have gained an enormous amount of application knowledge in various industries that is integrated into our offerings. We have truly mastered the physical principles our meters are based on: our ability to utilise physical effects and to find a matching measuring solution time after time are the reasons we are trusted by clients worldwide.

Our aim is to provide you with high-quality products that capture the primary measured value as accurate as possible to avoid consecutive faults that might affect your process control. This also enables our meters to measure reliably, even under changing or difficult process conditions. Both aspects are reflected by our claim **“Measure the facts”**.

This brochure should give you a comprehensive overview of our offerings. For detailed information or to contact us, please visit www.krohne.com or use the QR Codes you find on the pages.

KROHNE trademarks:

KROHNE
measure the facts
CalSys
CARGOMASTER
EcoMATE
EGM
KROHNE Care
M-PHASE
OPTIBAR
OPTIBATCH
OPTIBRIDGE
OPTIFLEX
OPTIFLUX
OPTIMASS
OPTISENS
OPTISONIC
OPTISOUND
OPTISWIRL
OPTISWITCH
OPTISYS
OPTIWAVE
PipePatrol
WATERFLUX
SENSOFIT
SMARTMAC
SMARTPAT

Trademarks of other owners:

Amphenol
Bluetooth®
DOWTHERM™
EtherNet/IP™
FDT Group
FOUNDATION™ fieldbus
HART®
HASTELLOY®
Metaglas®
NFC™
PACTware
PROFIBUS®
PROFINET®
VARIVENT®



www.krohne.com

Why choose KROHNE?

Driven by technology

To meet the changing requirements in the processes and projects of our customers, we use innovative technologies that are based on our extensive R&D activities: 10% of the KROHNE employees work in research and development.

Next to sensor physics, their focus is on device communication and enabling technologies for the Internet of Things (IoT) in process industry, e.g. ethernet communication to transmit process and device diagnostic data for evaluation and process optimisation.

Thus, our offering for you is continuously expanded with new measurement technologies, application-specific solutions and lifecycle services.



Local contacts, worldwide

A network of local subsidiaries is the foundation of all global companies. From our experience we know our customers prefer to work with local partners.

For you, we have established local contacts in over 100 countries, and built a network of development and production sites, sales and service organisations on all continents.



Industry-specific solutions

KROHNE has been a reliable partner for various industries for decades. Developing measuring solutions for industry-specific requirements and providing competitive advantages to you has always been our main task.



Products, solutions and services from KROHNE – One source portfolio for the entire value chain

A lot has changed since Ludwig Krohne introduced his first variable area flowmeter in 1921. Today KROHNE offers a complete portfolio of instrumentation, engineered solutions and services for all industries.



6 Products

Complete process instrumentation portfolio for all industries

- 8 Flow measurement
- 20 Smart flow control
- 22 Level measurement
- 32 Pressure measurement
- 34 Temperature measurement
- 40 Process analytics
- 48 Communication technology

Industry-specific portfolio

Products, solutions and services for various industries

Marine – 78

Oil & Gas – 74

Power
Generation /
Nuclear – 76

Sustainable
Energies – 82





50 Solutions

Engineered solutions for process control and automation

- 52 Flow metering solutions
- 54 Monitoring solutions
- 56 Wireless and remote metering solutions

58 Services

KROHNE Service – services for the complete project lifecycle

- 60 Core services
- 64 Support & training
- 65 Spare parts & repairs
- 65 Premium options
- 66 Service level agreements



Water &
Wastewater – 68

Chemical – 70

Metal & Mining – 80

Food & Beverage – 72



Products

Flow measurement · Level measurement · Pressure measurement ·
Temperature measurement · Process analytics

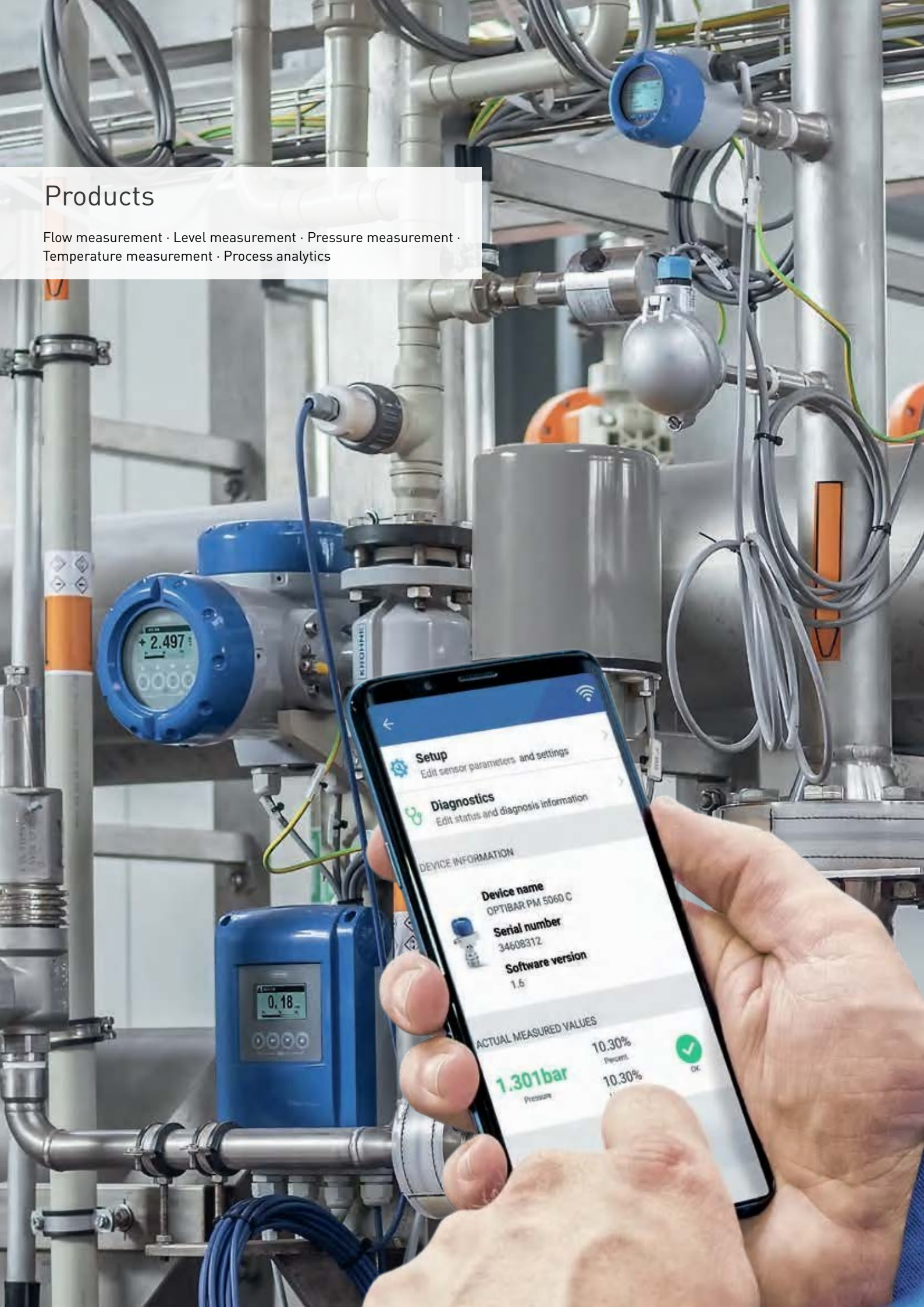

Setup
Edit sensor parameters and settings

Diagnostics
Edit status and diagnosis information

DEVICE INFORMATION

Device name
OPTIBAR PM 5060 C

Serial number
34608312

Software version
1.6

ACTUAL MEASURED VALUES

1.301bar 10.30%
Pressure Percent  OK

Complete process instrumentation portfolio for all industries

KROHNE offers a complete portfolio of instrumentation for flow, level, pressure and temperature measurement, and process analytics.

Our meters are used in just about every type of plant and processes around the world, and comply with a broad spectrum of industry standards and approvals. The expertise we have gained, spanning installation effects, different media and meter performance under real process conditions, adds value to every KROHNE meter you purchase.

Process instrumentation

Flowmeters and flow controllers

- 8 Electromagnetic
- 10 Coriolis Mass
- 12 Ultrasonic
- 14 Variable area
- 16 Differential pressure
- 18 Vortex
- 18 Mechanical and electromagnetic flow controllers
- 20 Smart flow control

Level measurement

- 22 FMCW radar
- 24 TDR guided radar
- 24 Ultrasonic
- 26 Hydrostatic pressure
- 28 Magnetic level indicators and bypass chambers
- 28 Displacer
- 30 Vibration switches
- 30 Capacitance switches

Pressure measurement

- 32 Diaphragm seals and combinations
- 32 Ultra-compact pressure transmitters
- 32 Compact pressure transmitters
- 32 Pressure transmitters

Temperature measurement

- 34 Temperature assemblies
- 36 Temperature transmitters
- 38 Compact sensors
- 38 Cable sensors
- 39 Accessories

Process analytics

- 40 pH
- 41 ORP
- 42 Conductive conductivity
- 42 Inductive conductivity
- 43 Total suspended solids
- 43 Disinfectant sensors
- 44 Dissolved oxygen
- 44 Turbidity sensors
- 45 Sludge level
- 45 Multiparameter measuring systems
- 46 Assemblies
- 46 Transmitters, Control and operating units
- 47 Accessories
- 48 Communication technology



Highlights

- From basic to demanding flow measurements, incl. custody transfer and safety-related applications (up to SIL2/3)
- Designs and liner materials for virtually any application – from potable water to extremely adhesive, abrasive and aggressive liquids
- Large choice of nominal sizes up to DN3000 / 120"
- Minimal or no inlets/outlets (OD/OD)
- All KROHNE EMF are wet-calibrated in a direct comparison of volumes
- Large choice of liner materials suitable for potable water, wastewater, chemicals, SIP/CIP
- Measurement independent of flow profile
- Wide range of custody transfer approvals together with industry related approvals, e.g. for drinking water or hygienic applications
- Abrasion and corrosion resistant liners
- Ceramic measuring tubes for flange and sandwich versions, optionally with non-wetted electrodes (capacitive flowmeter)
- Specific device for measurement of partially filled pipes
- 4-wire, 3 x 4...20 mA, HART®, Modbus, FF, PROFIBUS®-PA DP, PROFINET® etc.
- Unique virtual reference technology to avoid the use of large and expensive grounding rings and grounding electrodes



[krohne.link/emf-en](https://www.krohne.com/Link/emf-en)

Electromagnetic flowmeters

For all applications with conductive liquids

The measurement principle of electromagnetic flowmeters (EMF) is based on Faraday's law of induction. EMF can measure the volume flow of any electrically conductive liquid medium, even those with low conductivities.

Typical applications include:

- Water: revenue metering, district metering, water abstraction, leakage detection
- Wastewater: transport networks, sewage treatment plants, combined sewer overflows, sludges
- Food & beverage: mixing, dosing and filling of liquid dairy products under hygienic conditions, filling systems applications
- Chemical: acids, alkalis, dosing applications, abrasive or corrosive media
- Pulp & paper: pulp, pastes, sludges and other caustic media, liquor, additives, bleaches, colourants
- Metal & mining: media with a high solid content, like ore or excavator mud

OPTIFLUX 4400 in safety application



The modular product line

Converters



IFC 050
Basic applications
(Display/Blind)



IFC 100
Standard applications



IFC 300 & IFC 400
Advanced applications

Flow sensors



OPTIFLUX 1000
Sandwich (wafer)
device for compact
installation



OPTIFLUX 2000
For water and
wastewater
applications



WATERFLUX 3000
For small and
large flows without
requiring inlets or
outlets



OPTIFLUX 4000
For standard and
advanced process
and custody transfer
applications



OPTIFLUX 5000
Ceramic measuring
tube: maximum media
and abrasion resistance
and accuracy



OPTIFLUX 6000
For hygienic food
and pharmaceutical
applications

The specialists



OPTIFLUX 4400
For safety instrumented
systems (SIS) and high-
accuracy requirements



WATERFLUX 3070 C
Battery-powered water
meter for district metering
and custody transfer



TIDALFLUX 2300 F
For partially filled pipes,
Ex Zone 1



OPTIFLUX 7300 C flange
With non-wetted
capacitive electrodes
and ceramic liner



POWERFLUX 4300
For nuclear applications



POWERFLUX 5030
For nuclear applications,
with ceramic measuring tube



OPTIPROBE 1000
Insertion-type flowmeter for water
and wastewater applications



DWM 2000
Insertion-type flowmeter
for flow monitoring of
conductive media



AF-E 400
For utilities and
industrial automation



FLEXMAG 4050
For single use biopharma-
ceutical applications



BATCHFLUX 3100
For the volumetric
filling of common
container sizes



BATCHFLUX 5500
For volumetric filling
systems in the
beverage industry



OPTIMASS 1400
For universal applications
and process control

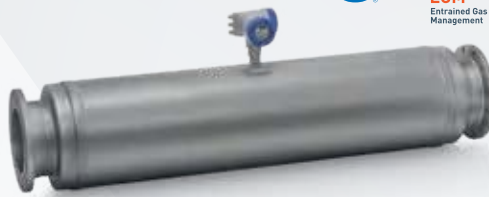

OPTIMASS 2400
Dual or four straight tube design for bulk
flows for custody transfer up to DN400/16"



OPTIMASS 3400
For low flow and
dosing applications



OPTIMASS 6400
For advanced process applications



OPTIMASS 7400
For advanced process applications,
with single straight measuring tube



OPTIGAS 4010
Specially designed for CNG and
LPG in dispensing systems



OPTIBATCH 4011
Specially designed for linear
and rotating filling machines



MFC 010
Modbus converter for
economical OEM system integration



OPTICHECK Flow Mobile
Mobile app for wireless on-site commissioning,
verification and monitoring

Coriolis mass flowmeters

For all process and custody transfer (CT) applications

The function of mass flowmeters is based on the Coriolis principle. They allow for a direct measurement of mass flow, density and temperature of liquids and gases as well as calculation of volume flow and mass or volume concentration with a single device.

Typical applications include:

- Chemical: measurement of concentration or density, bulk loading, batching to reactors, hydrocarbon cracking, aggressive, abrasive or viscous media or media of unknown composition
- Oil & gas: metering skids, bypass density measurement, CNG/LPG dispensers, leak detection, custody transfer applications such as tanker loading, bunkering and pipeline transfer
- Marine: loading and unloading, bunkering, fuel consumption and bunker-check onboard ship
- Food & beverage: filling machine applications, measurement of degrees Brix, flow, density, specific gravity, additive components dosing
- Pharmaceutical: batching, dosing and filling, solvent extraction, ultra-pure water measurement
- Pulp & paper: paper stock, pulp, additives, bleaches, colourants
- Water & wastewater: flocculent dosing, sludge flow and density measurement

OPTIMASS series: not susceptible to installation effects



Highlights

- Mass, volume flow and temperature measurement of liquids and gases, density and concentration measurement of liquids
- Secure wireless access via Bluetooth®, even in safety-related applications
- Maintains operation over a wide range of gas volume fractions, even up to 100%, and complex flow conditions (EGM™)
- Indication of and configurable alarms for entrained gas to improve processes
- Not susceptible to installation effects: no straight inlet/outlet pipe runs or flow conditioners required
- Approved for custody transfer applications in accordance with OIML R117/R137, MID MI-005/MI-002 and other leading global approvals
- 4-wire, 3 x 4...20 mA, HART® 7, Modbus, FF, PROFIBUS®-PA/DP, PROFINET, EtherNet/IP, etc
- Flow rates from 300 grams to 4,600 tons per hour / 0.01...169,000 lb/min
- Minimal pressure loss with straight tube measuring devices: reduced power consumption of pumps
- High density accuracy, not affected by medium and temperature changes
- Suitable for highly viscous media, inhomogeneous mixtures, media with solid content or gas inclusions with temperature range -200...+400°C / -364...+752°F
- 96% self-diagnostic capability to VDI / NAMUR / WIB 2650 and NE107



krohne.link/coriolis-en



Clamp-on flow measurement on large line size

Highlights

- Comprehensive portfolio for gases, liquids and steam
- High temperature and cryogenic versions, variants for high pressure and higher viscosities
- Various designs: From clamp-on devices to multipath inline flowmeters
- Accuracy and reproducibility regardless of medium properties such as viscosity, temperature, density and electrical conductivity
- Diagnostic and compensation functions for disturbed flow profiles and deposits, detection of gas entrainments in liquids, etc.
- No moving parts or components that protrude into the measuring tube
- Low operating and maintenance costs due to non-wearing parts
- Excellent long-term stability, no recalibration required
- High degree of reliability thanks to redundant measuring paths
- High-temperature versions available
- Bi-directional flow measurement



[krohne.link/
ultrasonicflow-en](https://www.krohne.com/en/ultrasonicflow-en)

Ultrasonic flowmeters

For process and utility applications, energy and custody transfer (CT) measurements

Using the transit time method, ultrasonic flowmeters measure liquid and gaseous media.

Typical applications include:

- Power plants: cooling water and demineralised water, steam, thermal oil (HTF), molten salt
- Chemical: metering of liquid hydrocarbons and low-conductivity liquids, including feedstock, solvents, chemical addition in reactor control metering, demineralised water
- Petrochemical refineries: feedstock, cooker feed flow, cracking, desulphurisation, residues, blending of crude oil and refined product
- Petrochemical plants: feedstocks (e.g. naphtha and natural gas), (intermediate) products such as ethylene, propylene, solvents
- Oil & gas: measurement of crude oil and refined product, natural gas, liquefied natural gas (LNG) and biogas; standard and custody transfer applications in production, pipeline transfer and leak detection, loading and off-loading, storage and distribution
- Water/utilities: demineralised water, water purification, effluent, compressed air
- HVAC: metering of chilled water and hot water for (custody transfer) energy measurement

For liquids



OPTISONIC 3400
For liquid process applications



OPTISONIC 3400 District Heating
For district heating applications



OPTISONIC 4400 HP
For high pressure liquids



OPTISONIC 4400 HT
For high temperature liquids



OPTISONIC 6300
Clamp-on flowmeter for flow measurement of liquids



OPTISONIC 6300 P
Portable clamp-on flowmeter for temporary flow measurement of liquids

Custody transfer



ALTOSONIC III
For custody transfer (CT) measurement of liquid hydrocarbons



ALTOSONIC 5
For custody transfer (CT) measurement in upstream and midstream applications

For gas and steam



OPTISONIC 7300
For natural gas, process gas and utility gas applications



OPTISONIC 7300 Biogas
For biogas, landfill and sewage gas applications



OPTISONIC 8300
For superheated steam and high temperature gases

Custody transfer



ALTOSONIC V12
For custody transfer measurement of natural gas

Metal devices



H250 M40
For liquids and gases, modular design: from mechanical indicator to 4...20 mA/HART®7, FF, PROFIBUS®-PA and totalizer



H250 M8
For liquids and gases, mechanical or with electronic bargraph indicator (4...20 mA/HART®)



DK32/34
For low liquid and gas flows



DK37 M8
For advanced low liquid and gas flows

Glass devices



DK46/47/48/800
For low flow gas or liquid applications and sample flow monitoring



VA40
For basic applications



VA45
For low pressure gas applications



K20
For basic water applications, plastic tube

Variable area flowmeters

For simple and cost-effective flow measurement of gases or liquids without auxiliary power

Variable area flowmeters are suitable for measuring pure liquids and gases. They have an upright conical tube made of metal, glass or plastic, in which a float moves freely up and down. The flow through the tube causes the float to rise until the forces are in equilibrium.

Typical applications include:

- Measuring small amounts of chemicals or additives
- Inerting with nitrogen for primary explosion protection
- Monitoring sample flows in process analyser systems
- Monitoring seal gases and barrier fluids for sealing systems at rotation equipment such as compressors
- Injecting corrosion, scale or hydrate inhibitors
- Gas or liquid purging of measuring systems
- Controlling gases at industrial furnaces and thermal process plants
- Totalising condensate or process water
- Measuring purified, demineralised water
- Measuring air, carbon dioxide, hydrogen, nitrogen or other technical gases

Measurement of sample flows in an analyser system



Highlights

- Purgemeters for low-flow applications <math><DN15 / 1/2''</math> and process meters up to $DN150 / 6''$
- Optional switches, 4...20 mA, HART®, FOUNDATION™ Fieldbus, PROFIBUS® PA
- Globally approved for use in hazardous areas and suited for safety related SIL 2 applications
- Float blocking and pulsation detection via Continuous Float Monitoring CFM
- Suitable from atmospheric to >1000 bar / 14503 psi bar operating pressure
- Compact installation without straight inlet / outlet sections
- Application-specific variants such as horizontal flow, extended turndown 100:1 or hygienic design
- Custom variants with special wetted materials or wet coating requirements
- High quality standards with comprehensive NDE and ITP meet also NACE, Norsok and even nuclear design codes
- Modular electronics design for exchange and upgrade in the field during operation
- Micro solutions: flowmeters with attached valve, flowmeters with mechanical flow regulators, engineered purge panels



Differential pressure flowmeters

For a wide range of process applications

Highlights

- For volume, mass flow and density measurement of liquids, gases or steam
- Complete assemblies with 3-D linearised differential pressure transmitters, calibration and documentation
- Compliance with all international standards acc. ISO 5167 and ASME MFC-3M, PED 2014/68 EU and CE marking
- Full uncertainty assessment for given operation conditions
- Fluid temperatures -200...+1000°C / -328...1832°F with pressure ratings up to PN700/ 10,000psi
- SIL2/3 certified
- Line sizes from DN15...2000 / 1/2" ... 80"
- Wet calibration up to DN3000 / 120", larger sizes on request
- Optimisation of measuring points according to a given specification, e.g. short inlet/outlet runs, low pressure loss, reduced overall uncertainty, etc.
- Individual sizing and engineering for each flow element and application
- Optional calibration on ISO 17025 accredited calibration rig for line sizes up to DN1400 / 56"
- Optimisation of measuring points according to a given specification, e.g. short inlet/outlet, low pressure loss, small overall uncertainty, etc.
- Compliant with PED 2014/68/EU with CE marking



krohne.link/dpflow-en

The principle of differential pressure (DP) is used to measure volume or mass flow of liquids, gases or steam. The pressure is measured at two points across a restriction in the line (e.g. a primary element). By using the Bernoulli equation, the difference in pressure between the two points is an indication for flow velocity and, as the pipe size is known, calculated to a volume flow rate.

Typical applications include:

- Feedwater and steam flow measurement at power plants
- Hot gas flows in thermal processes
- Geothermal steam flow and quality measurement
- Flow measurement in oil and gas production e.g. separators, gas lift, water and chemical injection, hydrocarbon vapours
- CCS / CO₂ injection
- Liquefied hydrogen (LH₂)
- Wet gas flow measurement
- Refined products flow measurement
- Measurement of cryogenic flows e.g. liquefied natural gas (LNG)
- Harsh process applications with abrasive and viscous media
- Cooling water, feedwater, condensate and steam in power plants
- High-temperature applications with dust-laden gases

Complete DP flow measuring point for compensated volume/mass flow

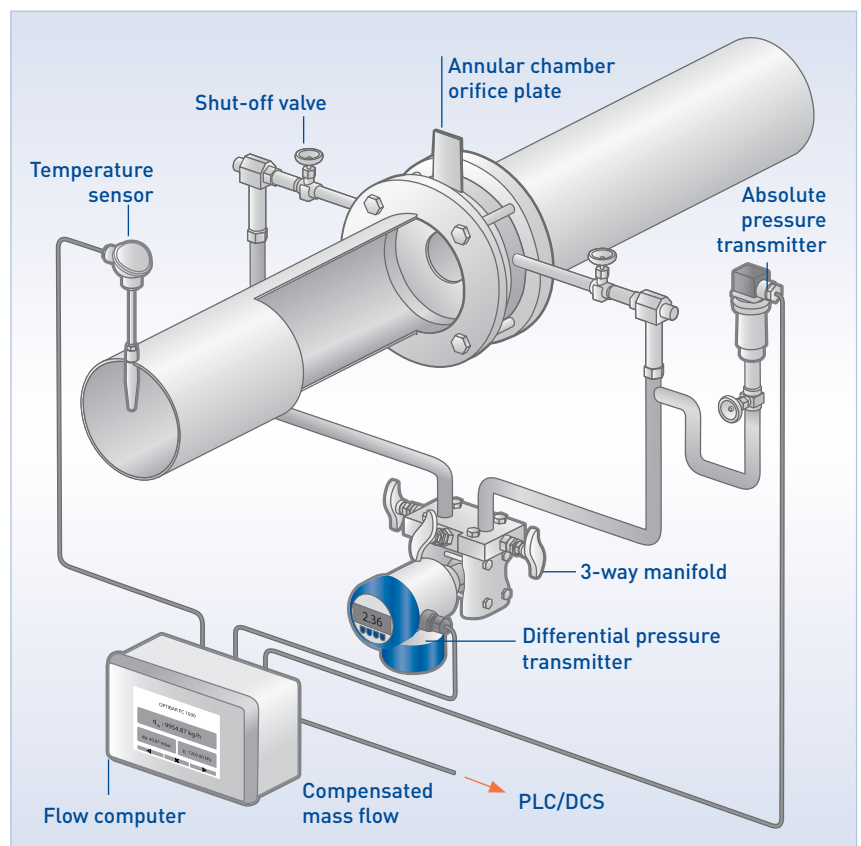



Compact orifice plate flowmeter
For liquids, gases and steam



Integral orifice meter run assembly
For process applications with small
line sizes (down to DN15 / 1/2)



Averaging pitot tube flowmeter
For applications with liquids, gases
and steam to high-temperature
applications with dust-laden gases



Flow nozzle meter
For long-term stable flow measure-
ment with reduced pressure loss



Venturi flowmeter
For the highest requirements of
accuracy and long-term stability



Wedge flowmeter
For harsh process applications
with abrasive and viscous media



Cone flowmeter
For limited installation space



OPTIBAR DP 3050
Differential pressure transmitter for
general flow, level and differential
pressure applications



OPTIBAR DP 7060
Differential pressure transmitter
for flow, level, differential pressure,
density and interface measurements



OPTICHECK Pressure Mobile
Mobile app for wireless on-site
commissioning, verification and
monitoring

Vortex flowmeters



OPTISWIRL 2100
For basic utility applications



OPTISWIRL 4200
For utility applications and energy
management systems



OPTISWIRL 5080
For high temperature applications

Mechanical flow controllers



DW 181
For clean liquids,
G3/4...2, 3/4...2 NPT



DW 182
For clean liquids,
DN15...65, 1/2...2 1/2"
ASME



DW 183
For clean liquids,
DN65...200, 3...8" ASME

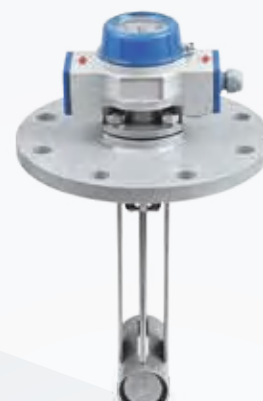

DW 184
Insertion-type flow controller
for pipe diameter ≥ 250 mm / 10",
process connection DN150,
6" ASME

Electromagnetic flow controllers



DWM 1000
For flow monitoring of
conductive media

Vortex flowmeters

For utility applications, advanced energy management and Safety Instrumented Systems (SIS)

Vortex flowmeters are based on the principle of the Kármán vortex street and are used in main as well as auxiliary and supply processes. Capable of compensating for different temperature and pressure conditions, they measure the volume flow of both conducting and non-conducting liquids, industrial gases and steam.

Typical applications include:

- Saturated steam and superheated steam
- Gross and net heat for energy management systems
- Hot steam, also for CIP and SIP processes
- All kinds of gases including liquefied gas, wet gas and flue gas
- Demineralised water and boiler feed water
- Solvents and heat transfer oil
- Steam boiler monitoring
- Compressor output and Free Air Delivery (FAD)

Mechanical flow controllers

For flow indication of conductive and non-conductive liquids

Mechanical flow controllers work via a spring-mounted baffle that changes its position as flow increases. Adjustable switches generate alarms once switching points are reached.

Typical applications include:

- Local flow indication of homogeneous, clean liquids without power supply e.g. for cooling systems, emergency showers, pump protection, lubrication control, or cavitation alarm

Electromagnetic flow controllers

For flow indication of conductive liquids

Based on Faraday's law of induction, electromagnetic flow controllers monitor or measure the flow speed of electrically conductive liquids.

Typical applications include:

- Flow measurement and monitoring of homogeneous and electrically conductive ($\geq 20 \mu\text{S}/\text{cm}$) liquids, pastes, and slurries e.g. for pump protection, cooling, or fire extinguishing systems.

Highlights

- Sophisticated flowmeters with integrated pressure and temperature compensation and integrated energy calculator for advanced energy measurement
- Certified for Safety Instrumented Systems (SIS), SIL 2/3 certified for continuous mode operation
- Cost-effective and robust devices for harsh process conditions and/or basic applications



krohne.link/vortex-en

Highlights

- Monitoring of homogeneous, clean liquids
- Autonomous, mechanical measuring principle with local indication - no power supply needed
- Ex-versions (Ex d, Ex i)



krohne.link/flowcontrollers-en

Highlights

- Measurement and monitoring of homogeneous and electrically conductive ($\geq 20 \mu\text{S}/\text{cm}$) liquids, pastes and slurries



krohne.link/flowcontrollers-en

Smart flow control

Smart meter valve for flow and decentralised process control

FOCUS-1 is the first smart meter valve specifically developed for the process industry 4.0. This multifunctional smart flow control instrument – developed by FOCUS-ON, a SAMSON and KROHNE company – combines sensors, actuator and control functionality in one device.

By measuring flow, pressure and temperature simultaneously and regulating its valve function independently, all specified set points can be accurately and reliably achieved. In this way, the device acts as an autonomous actuator for flow control and decentralised control tasks. This makes FOCUS-1 the ideal smart control unit for the autonomous factory. It is equally suitable for greenfield projects as well as a drop-in replacement of conventional valves in existing brownfield applications.

FOCUS-1 features extensive diagnostics. It knows its current status, can predict future conditions, and is capable of learning so as to adapt to process applications. Thanks to its “smart cavitation control” feature, FOCUS-1 is able to identify, monitor and alarm different kinds of cavitation caused in a pipeline. In this

way, operators are enabled to carry out predictive maintenance measures to avoid increased stress and wear of valve and piping ahead of time as well as to prevent unplanned downtime.

Due to its advanced algorithms, the smart meter valve can also create a „digital twin“. This allows modelling the measured data in such a way that device function and operation can be maintained even in the event of a sensor failure. With the help of the digital twin, plant operators implement redundancy and thus permanently increase the reliability, safety and availability of their plant.

The combination of sensors, valve and controller with extensive diagnostic features translates into less engineering effort, reduced sourcing and installation costs, a more simple and compact measuring set-up as well as more efficient life cycle management and maintenance. This simplifies processes, reduces system complexity and sustainably reduces capital expenditure (CAPEX) and operational expense (OPEX).

FOCUS-1 DN 80 in a flow control application





FOCUS-1
Smart meter valve for flow and
decentralised process control

Typical applications include:

- Control and regulation tasks in processes with conductive and non-conductive liquids
- Control loops in partially automated or autonomous operating plants ("digital factory")
- IIoT applications
- Instrumentation and control engineering (ICE) applications in many process industries, e.g. chemical and petrochemical, power generation, water/wastewater industry as well as factory automation and machinery/apparatus (such as skid manufacturers and other OEMs)
- Chemical process applications
- Heat exchanger applications
- Water applications (e.g. wastewater, cooling water)
- Inlet control to storage tanks and other vessels

Highlights

- Integrated control valve, flowmeter, pressure and temperature sensors combined with extensive computing power in one single device
- Full process control on valve positioning, flowrate, pressure or external process parameters with unique diagnostics
- Seamless integration into all automation systems, e.g. 4...20 mA, HART®, PROFINET®, Ethernet or Wi-Fi
- Extremely simple engineering, installation and operation whilst increasing control quality and plant uptime
- Redundancy: digital twin algorithms enable continuous operation even in the event of sensor failure
- DN50, DN80, DN100 / 2", 3", 4"
- Process pressure:
max. 36 barg / 522.1 psig
- Process temperature:
-40...+180°C / -40...+356°F



krohne.link/sfc-en

Radar (FMCW) level transmitters

Non-contact level measurement of liquids, pastes, granulates, powders and other solids



FMCW radar continuously emits a linear, frequency-modulated microwave signal with a constant amplitude which is reflected from the product surface and received back. These transmitters allow for the continuous, contactless level measurement of liquids, pastes, granulates, powders and other solids in a wide variety of industries:

- Chemical: acids, additives, alcohols, bases, benzene, butadiene, chlorine, corrosion inhibitors, ethylene, fertilizer (urea), foaming agent, granulates (PE, PP, PVC), ink, molten sulphur, paint, plastic powder, propylene, resins, solvents, soap powder
- Oil & gas: fuels, hydraulic oils, hydrocarbons, liquified gases (LPG), lubricant oil, slop oil
- Power generation: additive fuels (e.g. dried sludge, animal flour), coal, coke, condensates, cooling water, fly ash, molten salt, used solvents
- Agriculture, food & beverage: beer, cereals, cheese, chocolate, coffee or chocolate (beans, powder), flour, fruit (extract, juice, compote), liquor, milk (raw, powder), molasses, pet food, salt, soup, sugar, starch, vegetable oil, wine, yeast
- Marine: cargo level measurement (e.g. hydrocarbons, hot liquids) on large oil and product tankers, redundant ullage indication on ships
- Metals & mining: aggregates (recycled concrete, slag), building material (e.g. fine powders, sand, cement, filler, silica, gypsum), iron ore, rock products of different sizes (e.g. stone, gravel, grid), molten steel
- Life sciences: alcohols, bases, purified water, slightly corrosive acids, solvents, sterilized water, vaccine intermediates
- Water & wastewater: lime, lime milk, water (e.g. potable, river, rain, spring and sea), sludge, wastewater

Typical applications include:

- Level measurement in storage and process tanks of various shapes and sizes
- Accurate measuring values even in presence of tank internals (agitators, heating coils) or long nozzles
- Measurement of liquids and solids with fast changing levels: $\leq 60 \text{ m/min} / 196.85 \text{ ft/min}$
- Storage and process vessels requiring high accuracy
- Closed tanks and in the open air (e.g. floating roofs, dams)
- Up to $+200^\circ\text{C} / +392^\circ\text{F}$ in hazardous areas and up to $+700^\circ\text{C} / +1292^\circ\text{F}$ (e.g. molten salt in solar plants) in non-Ex applications

Highlights

- Measuring distances up to 100 m / 328 ft
- Different antenna options, e.g. for corrosive or abrasive media, high pressure or temperature and applications with agitators
- Also suitable for hazardous areas, Functional Safety (SIL) or hygienic applications
- Wide range of level transmitters: 10, 24 and 80 GHz
- Extensive choice of process connections starting from 3/4"
- Drop antennas made of plain PP, PEEK or PTFE: their ellipsoidal shape and non-adhesive surface prevents product deposit in dusty or humid atmospheres
- Suitable for high and low process pressure/temperature applications



krohne.link/optiwave-products-en



OPTIWAVE 1400
For liquids in water and
wastewater applications



OPTIWAVE 3500
For liquids with hygienic
requirements



OPTIWAVE 5400
For liquids in basic process applications



OPTIWAVE 6400
For solids from
granulates to rocks



OPTIWAVE 6500
For powders and
dusty atmospheres



OPTIWAVE 7400
For agitated and
corrosive liquids



OPTIWAVE 7500
For liquids in narrow tanks
with internal obstructions



OPTIWAVE-M 7400
For liquids and solids in
the marine industry



OPTIWAVE-M 7500
For liquids and solids in
the marine industry

Guided radar (TDR) level transmitters



OPTIFLEX 1100
For basic applications
with liquids



OPTIFLEX 3200
For liquids with hygienic
requirements



OPTIFLEX 6200
For solids from
granulates to powders



OPTIFLEX 7200
For advanced liquid
applications



OPTIFLEX 8200
For liquids at
high temperature
and pressure



POWERFLEX 2200
For the nuclear industry

Ultrasonic level transmitters



OPTISOUND 3010 C
2-/4-wire ultrasonic
level transmitter for
small vessels



OPTISOUND 3020 C
2-/4-wire ultrasonic
level transmitter
for small and
medium-sized vessels

Guided radar (TDR) level transmitters

Contact level measurement of liquids, solids or liquid-liquid interfaces

TDR radar (Time Domain Reflectometry) emits electromagnetic pulses which are transmitted along a rigid or flexible conductor before being reflected from the product surface and received. It allows for continuous level measurement of liquids, pastes, granulates, powders and liquid interface.

Typical applications include:

- Chemical: solvents, alcohols, acids, bases, ethylene, propylene, additives, CO₂, NH₃, foaming agent, butadiene, fuels, biodiesel, hydraulic and lubricant oil, benzene, chlorine, resin, paint, ink
- Oil & gas: slop and lubricant oil, hydrocarbons (e.g. oil/water interface in separators), liquefied gases (LPG), condensates, benzene, distillation towers
- Power generation: hydrocarbons, fly ash, liquefied gases (LPG), condensates, cooling water, fuel control of emergency generators and cooling water, recycled frying oil boilers
- Nuclear: safety- and non-safety-related applications, liquid level measurement in radiation conditions up to severe accident scenarios, high-accuracy level measurement in pools
- Water & wastewater: water in storage or recycling tanks, basins, ports or locks, water purification systems
- Metal & mining: fine powders such as cement, lime, silica or gypsum
- Food & beverage: fruit extract, juice or compote, yeast, beer, wine, milk, coffee and chocolate powder, raw milk or cheese, tomato sauce, soup, tobacco, vegetable and palm oil
- Life sciences: vaccines, plasma, purified water, aqueous solutions, alcohols, solvents, chlorobenzene, chloroform, slightly corrosive acids, and alkalis

Highlights

- Measuring distances up to 60 m / 196 ft
- Large choice of probes, e.g. for aggressive media, high pressure or temperature and tanks with internals or boiling product surfaces
- Suitable for hazardous areas, Functional Safety (SIL) or hygienic applications
- 2-wire, 4...20 mA (HART® 7) guided radar (TDR) for distance, level, volume, mass or interface measurement
- Not affected by process conditions: dust, foam, vapour, agitated or boiling surfaces, changes in pressure, temperature and density
- Accuracy from ±2 mm / ±0.08"
- High temperature (HT) and high pressure (HP) up to +315°C / +599°F, 320 barg / 4641 psig



krohne.link/tdr-en

Ultrasonic level transmitters

Non-contact level measurement of liquids, bulk and solids

This transmitter type emits ultrasonic pulses which are reflected from the product surface and received. It is suitable for continuous, non-contact level measurement of liquids and solids.

Typical applications include:

- Chemical: acids, bases
- Water & wastewater: sewage, potable, river, sea and rainwater
- Non-contact flow measurement in open channels
- Level of solids in hoppers
- Stormwater overflow
- Sumps, water and wastewater basins

Highlights

- Measuring distances: 0.25...8 m / 0.82...26.2 ft (liquids), 0.25...3.5 m / 0.82...11.5 ft (solids)
- Resistant materials for transducers and process connections, e.g. for slightly corrosive media
- Also suitable for hazardous applications



krohne.link/ultrasoniclevel-en

Pressure level transmitters

Contact level measurement of liquids and liquid-liquid interfaces

Highlights

- From entry level ultra-compact to advanced hydrostatic process pressure transmitters
- For a broad range of applications, with metallic and ceramic sensors
- Full compliance with hygienic, marine, hazardous area and safety related (SIL) applications.
- Level, density or interface measurement of liquids with process temperatures up to -400°C / $+752^{\circ}\text{F}$
- Process connections for all applications, also 3A and EHEDG approved hygienic connections
- Differential pressure transmitter with integrated absolute pressure measurement to measure head pressure
- Measuring range starting at 10 mbar / 0.14 psi
- Interface measurement, also with emulsion layers
- Multiple functions for vessel linearization integrated in converter
- NACE compliant materials
- Use in hazardous areas
- Smallest measuring span 10 mbar / 0.145 psi gauge
- 2-wire 4...20 mA HART® 7, FOUNDATION™ fieldbus, PROFIBUS® PA and IO-Link

Hydrostatic pressure is used to measure level or density of a liquid in a vessel. The OPTIBAR modular product line offers a complete portfolio for hydrostatic level measurement of corrosive and non-corrosive liquids and slurries.

Typical applications include:

- Level measurement of liquids in open and pressurised vessels
- Level measurement in vessels with agitators
- Hygienic level measurement applications
- Steam boiler monitoring
- Level or interface measurement in distillation columns
- Level measurement in water wells, rainwater retention / overflow basins



Level measurement in pressurised vessel



[krohne.link/
pressurelevel-en](https://www.krohne.com/pressurelevel-en)



OPTIBAR P 1010
Pressure transmitter
for basic pressure and
level applications



OPTIBAR P 2010
Pressure transmitter
for hygienic pressure and
level applications



OPTIBAR LC 1010
Submersible level probe for water
and wastewater applications



OPTIBAR PSM 1010
Pressure switch for basic
pressure and level applications



OPTIBAR PSM 2010
Pressure switch for hygienic level
and pressure applications



OPTIBAR PM 3050
Pressure transmitter for general
pressure and level applications



OPTIBAR PC 5060
Pressure transmitter for
advanced process pressure
and level applications



OPTIBAR PM 5060
Pressure transmitter for process
pressure and level applications



OPTIBAR 5060 eDP
Electronic differential pressure
transmitter for level, differential
pressure and density measurements



OPTIBAR DP 7060 with diaphragm seal
Differential pressure transmitter for
advanced applications and high temperatures

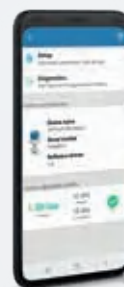

OPTICHECK Pressure Mobile
Mobile app for wireless on-site
commissioning, verification and
monitoring

Magnetic level indicators and bypass chambers



BM26A-1000
For basic liquid applications



BM26A-3000
For corrosive liquids



BM26A-5000
Bypass chamber for TDR
guided radar, FMCW radar and
displacer level transmitter



BM26A-6000
For liquefied gas



BM26A-7000
For extreme
operating
conditions



BM26A-8000-BI
With level transmitter for
redundant measurement in
a single measuring chamber



BM26A-8000-TWIN
With level transmitter for
redundant measurement in
two measuring chambers
connected adjacent to each other

Displacer



BW 25
Broadband displacer
level transmitter for
high pressures and
temperatures

Magnetic level indicators and bypass chambers

Liquid level or interface indication without power supply

Magnetic bypass level indicators (MLI) are based on the principle of communicating vessels and allow for continuous level or interface measurement of liquids.

Typical applications include:

- Chemical: additives, alcohols, acetone, acids (e.g. hydrofluoric, hydrochloric, nitric, sulphuric), ammonia (NH₃), corrosives, carbon dioxide (CO₂), chloralkali, chlorine, ethylene, heat transfer fluids, freon, gasoline, gas condensate, glycol, inks, nitrogen, solvents, turpentine, toluene, xylene
- Oil & gas: crude oil, lubrication oils, hydraulic fluids, diesel fuel, butane, propane, liquified gas (LPG), naphtha, interface in oil/water separators
- Power generation: condensate, therminol, DOWTHERM™
- Water & wastewater: water
- Pulp & paper: mill water

Highlights

- Magnetic float level gauges for an extensive range of applications in all industries
- Rugged metallic design, flaps housed in hermetically-sealed glass tube (IP68), no maintenance
- Measuring ranges from 0.3 m / 1 ft to 5.5 m / 18 ft (other dimensions on request)
- Highly visible level indication works without power supply
- Large variety of accessories and options: valves, thermal insulation, various materials, hazardous area approvals, interface measurement, limit switches, level transmitters, etc.
- Designed for pressures up to 400 barg / 5801 psig and temperatures from -196 up to +400°C / -321 up to +752°F



[krohne.link/
levelindicators-en](https://krohne.link/levelindicators-en)

Displacer level transmitters

Contact level measurement of liquids and liquid-liquid interfaces in tanks or bypass chambers

Based on the Archimedes or displacer principle, these transmitters measure level and separating layers of liquids.

Typical applications include:

- Chemical: solvents, bases, alcohols, ammonia
- Power generation: boiler, water
- Oil & gas: hydrocarbons e.g. interface measurement on hydrocarbons

Highlights

- Measuring ranges from 0.3 m / 1 ft to 6 m / 20 ft (other dimensions on request)
- For a broad range of process conditions, e.g. pressurised or high temperature vessels, corrosive media etc.
- Suitable for hazardous areas
- Universal device for measuring level or interface of various liquids under extreme conditions



[krohne.link/
displacer-en](https://krohne.link/displacer-en)

Highlights

- Insertion lengths up to 6 m / 19 ft (liquids) or 80 m / 262 ft (solids)
- Insensitive to changes of media properties, e.g. viscosity, dielectric constant (ϵ_r) or electrical conductivity
- For high/low level detection, dry-run and overflow prevention even in highly critical applications (SIL, HT/HP) or hygienic environments
- Rugged oscillating fork, high abrasion resistance
- Reproducible switching point without adjustment
- Continuous self-monitoring of correct oscillating frequency, corrosion and cable breakage to the Piezo drive



[krohne.link/
vibrationlevel-en](https://krohne.link/vibrationlevel-en)

Vibration level switches

Point level detection of liquids and solids

Vibration switches indicate the presence of liquid or solids when the medium comes in contact with their vibrating forks and dampens their oscillation.

Typical applications include:

- Limit and overflow detection
- Pump dry-run protection
- Liquid detection in pipes
- High-temperature and high-pressure applications e.g. steam boilers
- Light bulk goods
- Hygienic vessels
- Detection of solids in water
- Applications with heavy dust build-up and mechanical stresses

Highlights

- Compact housing with very short insertion length of 15 mm / 0.59"
- For standard and advanced hygienic applications in tanks or pipelines
- Detects foam or even a change in media characteristics, e.g. the degree of water contamination
- Measurement independent of media properties
- Not sensitive to adhesives and foam, condensate or build-up of deposits
- Hygienic installation by means of a hygienic process weld sleeve, almost flush-mounted



[krohne.link/
capacitancelevel-en](https://krohne.link/capacitancelevel-en)

Capacitance level switches

Point level detection of liquids, liquid-liquid interface and solids

A capacitance switch uses the phase shift that electromagnetic waves experience when emitted to a medium. It is suitable for level detection for liquids and pastes or as a dry-run protection. It can also detect liquid-liquid interfaces or identify the presence of a specific medium.

Typical applications include:

- Level detection in the food & beverage, life sciences, water and marine industries
- High- or low-level alarms for liquids or solids (ϵ_r -value >1.5)
- Dry-run protection
- Liquid-liquid interface detection
- Small tanks and hygienic applications
- Sticky, crystallising media or environments with strong external vibrations
- Media with changed characteristics e.g. fermentation process in breweries

Vibration



OPTISWITCH 3100
For solid applications



OPTISWITCH 3200
For solid applications,
with cable extension



OPTISWITCH 3300
For solid applications,
with rigid extension



OPTISWITCH 4000
For basic applications



OPTISWITCH 5100
For process applications



OPTISWITCH 5150
For liquids in hygienic
applications



OPTISWITCH 5200
For process applications,
with rigid extension



OPTISWITCH 5250
For hygienic applications,
with rigid extension



OPTISWITCH 5300
For heavy-duty
applications

Capacitance



OPTISWITCH 6500
For advanced hygienic
applications



OPTISWITCH 6600
For hygienic and industrial
applications

Highlights

- From entry level ultra-compact to advanced process pressure transmitters
- For a broad range of applications, with metallic and ceramic sensors
- Full compliance with hygienic, marine, hazardous area and safety related (SIL) applications
- Process pressures
-1...+1000 bar / -14...+14500 psi gauge
and 0...+600 bar / 0...+8700 psi absolute
- Process temperatures up to +150°C / +302°F without diaphragm seal
- Duplex, HASTELLOY® C-276, PVDF and many other special materials as well as compliant NACE
- Optional display and adjustment module
- 2-wire 4...20 mA HART® 7, FOUNDATION™ Fieldbus, PROFIBUS® PA and IO-Link



krohne.link/pressure-en

Process pressure

For absolute, gauge and differential pressure measurement

Process pressure transmitters are used to measure pressure in pipes or vessels.

For differential pressure (DP) flow measurement please refer to chapter "DP Flow", page 16.

For level, density and interface measurement with hydrostatic pressure, please refer to chapter "Hydrostatic pressure", page 26.

Typical applications include:

- Pump dry-run protection and compressor monitoring
- Flue gas ventilation control
- Monitoring processes from low pressure to absolute vacuum
- Overload resistant level and overpressure measurement in batch tanks
- Monitoring of supply pressure in pipelines

Diaphragm seals



OPTIBAR DSP & DSD series



Ultra-compact pressure transmitters



OPTIBAR P 1010
For basic pressure and level applications



OPTIBAR P 2010
For hygienic pressure and level applications



OPTIBAR LC 1010
Submersible level probe for water and wastewater applications



OPTIBAR PSM 1010
Pressure switch for basic pressure and level applications



OPTIBAR PSM 2010
Pressure switch for hygienic level and pressure applications

Compact pressure transmitters



OPTIBAR PM 3050
Pressure transmitter for general pressure and level applications



OPTIBAR DP 3050
Differential pressure transmitter for general flow, level and differential pressure applications

Pressure transmitters for process pressure and level applications



OPTIBAR PC 5060
For advanced applications, with corrosion and abrasion resistant ceramic diaphragm



OPTIBAR PM 5060
With fully welded metallic diaphragm for high pressure ranges and hygienic requirements



OPTIBAR 5060 eDP
Electronic differential pressure transmitter for level, differential pressure and density measurements



OPTIBAR DP 7060
Differential pressure transmitter for hydrostatic level measurement with integrated absolute pressure measurement

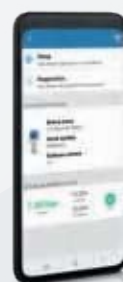

OPTICHECK Pressure Mobile
Mobile app for wireless on-site commissioning, verification and monitoring

Highlights

- With ASME-, DIN- and NAMUR-style thermowells or customer-specific designs
- Various process connections available
- For temperature measurement across a wide range of industrial applications
- Various process connections: insert, screw-in/threaded, flanged, weld-in, compression fittings, coatings and covers, gas-tight threaded sleeves, sliding flange
- Standardised and customer-specific temperature assemblies
- Replaceable spring-loaded measuring inserts made from mineral isolated cable, durable, with low drift and high resistivity against any mechanical load
- Connection heads for a wide variety of requirements
- Extensive range of accessories
- Reduced and tapered tips for faster response
- Wide range of materials
- Additional PTFE or tantalum coating for use in conditions like exposure to a high level of chemicals
- Corrosion and abrasion-resistant versions
- Individual stress calculations
- Various test and examination certificates available, including pressure test, PMI test, X-ray test, ultrasonic test, dye penetration test



[krohne.link/
tempassemblies-en](https://krohne.link/tempassemblies-en)

Temperature assemblies

With measuring insert (RTD or TC)

KROHNE has a wide portfolio of standard pre-fitted temperature assemblies for solid, liquid, gaseous and steaming media. We can also provide you with systems that are custom-made for your specific requirements.

Typical applications include:

- Chemical: measurement of liquids, gases and solids, acids and alkalis, abrasive or corrosive media in pipes, vessels and reactors
- Iron & steel: measurement in production and during the thermal treatment of steels, gas and ovens, as well as cooling media temperatures
- Power generation: steam and flue gas, as well as measurements of cooling media and bearing temperatures
- Hygienic applications: production and cleaning processes according to the stringent requirements of GMP, FDA, EHEDG and others



Temperature assemblies (with RTD or TC measuring insert)

Flange



OPTITEMP TRA-F/TF and TCA-F/TF
For standard applications up to higher flow velocities and pressures

Plug-in



OPTITEMP TRA-P and TCA-P
For standard up to high temperature applications

Screw-in



OPTITEMP TRA-S and TCA-S
For standard applications, lower temperatures, use in existing thermowells or machinery, or with higher flow velocities and pressures

Weld-in



OPTITEMP TRA-T/TW and TCA-T/TW
For higher flow velocities and pressures

Hygienic fitting



OPTITEMP TRA-H
For hygienic applications

Clamp-on



OPTITEMP TRA-G
For surface temperature measurement in industrial applications



OPTITEMP TT 12
With RTD or TC input and
extremely compact design



OPTITEMP TT 22
With RTD input



OPTITEMP TT 31
With universal inputs, dual channel
and high galvanic isolation



OPTITEMP TT 32
Rail-mounted temperature
transmitter with universal inputs
and high galvanic isolation



OPTITEMP TT 33
With universal inputs and
galvanic isolation



OPTITEMP TT 40 C
Head-mounted temperature
transmitter with universal
inputs and galvanic isolation



OPTITEMP TT 51
With universal dual input, galvanic
isolation, HART® and SIL



OPTITEMP TT 53
With universal input, galvanic
isolation, HART® 7, NFC and
Bluetooth® communication

Temperature transmitters

Head-mounted and rail-mounted versions

In 1974, INOR launched the world's first temperature transmitter which could be built into the connection head of a temperature assembly to convert the sensitive thermometer signal into a stable, noise-immune signal directly at the measuring point. Today, KROHNE INOR has an extensive programme, based on years of experience developing transmitters, covering low to high-performance accuracy, fail-safe measuring that fits into all kinds of applications in the process industries.

Typical industries include:

- Machine-building industry
- HVAC applications
- Energy & power generation
- Petrochemical
- Oil & gas



Highlights

- From cost-effective analogue versions to digital, programmable variants with enhanced diagnostics
- Intrinsically safe and SIL2 certified designs
- For temperature measurement across a wide range of industrial applications
- Analogue temperature transmitters for basic applications
- Digital, universally programmable state-of-the-art transmitters for demanding applications
- Fits any B-connection head and on DIN rail
- Excellent measurement accuracy with high precision, long-term stability and low temperature drift
- HART® 7 compatible transmitters
- Diagnostic functions for high process safety: monitoring of isolation resistance (SmartSense), sensor drift, sensor breakage and short circuit
- Dual sensor input TC and RTD, 2-, 3- and 4-wire (4-wire on OPTITEMP TT 51 R only) with automatic back-up in case of sensor failure (redundancy)
- High galvanic isolation
- NAMUR compliance: NE 21/NE 43/NE 53/NE 89/NE 107
- 10-g vibration resistance



Resistance (RTD) compact sensors

For industrial process, OEM, HVAC or hygienic applications with limited space

Highlights

- Temperature range: -50...+600°C / -58...+1000°F for RTD
- Extremely small housing with optional built-in transmitter



krohne.link/rtdcompact-en



OPTITEMP TRA-C/V
For industrial process, OEM, HVAC or hygienic applications with limited space

Resistance (RTD) cable sensors

For surface, underground, bearing or plastic moulding machinery applications

Highlights

- Temperature range: -50...+600°C / -58...+1000°F for RTD
- Different variants: with flying wires, vibration-proof, oil-tight, IP68, with different cable insulating materials



krohne.link/rtdcable-en



OPTITEMP TRA-G/W
For surface and underground measurement or bearing and plastic moulding machinery applications

Thermocouple (TC) cable sensors

For temperature assemblies and transmitters

Highlights

- Temperature range: up to +1250°C / +2282°F, for TC J, K or N
- Different mineral insulated variants: with flying wires, connection head or thermo plugs



krohne.link/tccable-en



OPTITEMP TCA-M
For machinery and high temperature applications

Temperature accessories

For temperature assemblies and transmitters



OPTITEMP TT-CON BT
Transmitter configuration kit for remote configuration and monitoring of temperature transmitters



OPTITEMP TT-CON EX
Transmitter configuration kit for PC configuration of OPTITEMP transmitters



OPTITEMP TC 100
Measuring insert with thermocouple (TC) type K or J



OPTITEMP TR 100
Measuring insert with Pt100 resistance sensor (RTD)

Highlights

- Configuration tool for programmable temperature transmitters
- Measuring inserts (RTD or TC)
- Connections heads, thermowells, fittings



[krohne.link/
tempaccessories-en](https://krohne.link/tempaccessories-en)

OPTICHECK Temperature Mobile

Mobile app for temperature transmitters

OPTICHECK Mobile is a mobile app for wireless on-site commissioning, verification and monitoring of KROHNE measuring devices. It is the ideal service tool to manage all device settings via a secure Bluetooth connection. In this way, a variety of commissioning tasks, e.g. zero calibration or configuration of diagnostics, can be done wirelessly. The mobile app also enables thresholds for certain parameters to be set and adjusted via a mobile device.



Highlights

- Currently available for OPTITEMP TT 12 C and R, OPTITEMP TT 33 C and R as well as OPTITEMP TT 53 C
- Wireless configuration, monitoring and basic verification



[krohne.link/
tempapp-en](https://krohne.link/tempapp-en)

pH sensors

For potentiometric analysis of liquids



SMARTPAT PH 1590
For potable, process or treated water applications



SMARTPAT PH 2390
For process, municipal and industrial wastewater applications



SMARTPAT PH 8150*
For chemicals and industrial wastewater applications



SMARTPAT PH 8320*
For water and wastewater applications



SMARTPAT PH 8530
For pure water and low conductivity media (>2 µS/cm)



SMARTPAT PH 8570*
For food, beverage and pharmaceutical applications



OPTISENS PH 8100
For chemicals and pure water applications (>2 µS/cm)



OPTISENS PH 8300
For wastewater, surface and process water applications



OPTISENS PH 8390
For wastewater applications



OPTISENS PH 8500
For potable water applications



OPTISENS PH 8590
For water and wastewater applications



OPTISENS PH 9100
For lower conductivity water applications (>20 µS/cm)



OPTISENS PH 9500
For lower conductivity water applications (>50 µS/cm)

*also available with Ex approval

Highlights

- Sensors with or without integrated transmitter (4...20 mA / HART®)
- Glass or rugged plastic body sensors with different membrane glass and diaphragm types for a broad variety of applications
- Also available as pre-wired panel module for simultaneous measurement of pH and other parameters
- Ex approvals (zone 0) e.g. ATEX, FM, IECEx
- Extended lifetime of sensors due to the offline calibration and regeneration
- Offline statistic over complete life cycle
- Ingress protection IP68
- Different diaphragm materials for all applications



krohne.link/ph-en

ORP sensors

For potentiometric analysis of liquids



SMARTPAT ORP 1590
For water and wastewater applications



SMARTPAT ORP 8150*
For chemicals and industrial wastewater applications



SMARTPAT ORP 8510
For water and wastewater applications



OPTISENS ORP 8500
For water and wastewater applications



OPTISENS ORP 8590
For water and wastewater applications

Highlights

- Sensors with or without integrated transmitter (4...20 mA / HART®)
- Glass or rugged plastic body sensors with platinum electrode and different diaphragm types for a wide range of applications
- Also available as pre-wired panel module for simultaneous measurement of ORP and other parameters
- Ex approvals (zone 0) e.g. ATEX, FM, IECEx



krohne.link/orp-en

KROHNE is your partner for all aspects of analytical instrumentation, from pH measurement in hazardous areas to sludge level and sedimentation measurement on wastewater treatment plants. We offer a comprehensive portfolio of liquid analytical sensors with and without integrated transmitter, complete measuring systems as well as installation equipment, transmitters and accessories to match the requirements of various industries.

Our main goals are attaining sturdiness, reliability and quality in the various application areas. We will gladly assist you in the search for the optimum solution to your measurement task. Should it be necessary to specifically design a measuring system according to your requirements, we are able to modify our systems in line with your needs and include additional components.



pH measurement in a dairy
with insertion assembly

Conductive conductivity sensors and measuring systems

For conductive conductivity measurement

Highlights

- Sensors with or without integrated transmitter (4...20 mA / HART®)
- Different cell constants and electrode materials for a wide range of applications – from ultrapure water to potable water to CIP agents
- Also available as compact systems with integrated electronics or as pre-wired panel module for simultaneous measurement of conductivity and other parameters
- Ex approvals (zone 0) e.g. ATEX, FM, IECEx
- Offline statistic over complete life cycle



krohne.link/cond-en



SMARTPAT COND 1200
For water and wastewater applications



SMARTPAT COND 3200
For condensate, process, boiler feed or (ultra)pure water



SMARTPAT COND 5200*
For chemicals and industrial wastewater applications



SMARTPAT COND 7200
For food, beverage and pharmaceutical applications

*also available with Ex approval



OPTISENS COND 1200/1210
For water, wastewater, process water or pure water



OPTISENS COND 7200/7230
For food, beverage and pharmaceutical applications

Inductive conductivity sensors and measuring systems

For inductive conductivity measurement

Highlights

- Electrodes not in contact with the media
- Different materials for all applications e.g. PVDF, PP, PEEK
- Insensitive to contamination
- Integrated automatic temperature compensation with fast response time



krohne.link/cond-en



OPTISENS IND 1000 (PP)
For water, wastewater and chemical applications



OPTISENS IND 7000
For food and beverage applications



OPTISYS IND 7100
For food and beverage applications



OPTISYS IND 8100
For food and beverage applications

Total suspended solids sensors and measuring systems

For optical TSS measurement



OPTISENS TSS 2000
Optical TSS sensor for
wastewater applications



OPTISENS TSS 3000
Optical TSS sensor for
wastewater applications



OPTISENS TSS 7000
Optical TSS sensor for
hygienic applications



OPTISYS TSS 1050/3050
For hygienic applications,
process connection G1/2



OPTISYS TSS 2050/4050
For hygienic applications,
process connection
PG 13.5 for use in
retractable assemblies

Highlights

- Membrane-free sensor designs with automatic sensor cleaning function
- Also available as pre-wired module for simultaneous measurement of Cl_2 , ClO_2 or O_3 and other parameters (pH, temperature etc.)
- For water and wastewater applications in various industries
- Membrane-free sensor for long-term stability
- Gel-filled 12 mm sensor for a wide range of applications
- Amperometric measurement with fast response time



krohne.link/tss-en

Disinfectant sensors and measuring systems

For potentiostatic amperometric measurement of free chlorine, chlorine dioxide and ozone



OPTISYS CL 1100
Potentiostatic amperometric
disinfectant measuring
system for water and
wastewater



OPTISENS CL 1100
Potentiostatic amperometric
disinfectant sensor for water
and wastewater applications

Highlights

- Membrane-free sensor designs with automatic sensor cleaning function
- Also available as pre-wired module for simultaneous measurement of Cl_2 , ClO_2 or O_3 and other parameters (pH, temperature etc.)
- For water and wastewater applications in various industries



[krohne.link/
disinfectant-en](https://krohne.link/disinfectant-en)

Dissolved oxygen sensors and measuring systems

For amperometric or optical analysis of dissolved oxygen

Highlights

- Different sensor versions with rugged materials
- Also available as pre-wired panel module for simultaneous measurement of dissolved oxygen and other parameters
- For water and wastewater applications in various industries



[krohne.link/
dissolved-en](https://www.krohne.com/en/dissolved-en)



OPTISENS ADO 2000
Amperometric oxygen sensor
for water and wastewater
applications



OPTISENS ODO 2000
Optical oxygen sensor for water
and wastewater applications

Turbidity sensors and measuring systems

For optical turbidity measurement

Highlights

- Different sensor designs for immersion and insertion or as compact system with integrated electronics and flow cell
- Scattered light technology according to EPA 180.1 or ISO 7027 (NIR-LED)
- For water and wastewater applications in various industries
- Precise turbidity measurement < 40 FNU/NTU through the 90° scattered light method



[krohne.link/
turbidity-en](https://www.krohne.com/en/turbidity-en)



OPTISENS TUR 2000
For water and wastewater
applications



OPTISYS TUR 1060
Measuring system
for potable water
applications

Sludge level measuring systems

For optical measurement of sludge blanket level and concentration



OPTPTISYS SLM 2100
Optical sludge level measuring system for sedimentation profile measurement and continuous tracking of sludge blanket

Highlights

- Compact solutions with integrated electronics
- Direct measurement by 180° transmission of light (NIR-LED)
- Low maintenance due to cable wiper and automatic flushing of sensor and cable after each measuring cycle
- For water and wastewater treatment, mining and power applications



[krohne.link/
sludgelevel-en](https://krohne.link/sludgelevel-en)

Multiparameter measuring systems

For simultaneous measurement of different parameters



Water analysis panel
Multi-parameter measuring system
for water quality monitoring

Highlights

- Pre-assembled and pre-wired modules for fast commissioning
- Application-specific selection of water quality parameters
- Effective process control, reduced installation costs



[krohne.link/
multiparameter-en](https://krohne.link/multiparameter-en)

Analytical assemblies

Installation equipment for all analytical sensors

Highlights

- Retractable, immersion or insertion housings
- Flow-through process adaptations and weld-in sockets
- For use in harsh environments, hazardous areas, hygienic or other applications



[krohne.link/
paassemblies-en](https://krohne.link/paassemblies-en)



Flow-through assemblies
for process analytics
For installation of assemblies or sensors into pipes



Automatic retractable assemblies
For installation of $\varnothing 12$ mm / 0.47"
sensors with sensor length 225 mm / 8.9"



Manual retractable assemblies
For installation of $\varnothing 12$ mm / 0.47"
sensors with sensor length 120 and
225 mm / 4.7 and 8.9"



Insertion assemblies
For installation of $\varnothing 12$ mm / 0.47"
sensors with sensor length
120 mm / 4.7"



Immersion assemblies
for process analytics
For immersion installation
of various sensor types



Mounting assemblies
for process analytics
For welding assemblies
into pipes and tanks

Analytical transmitters & Control and operating units

For liquid analytical sensors

Highlights

- Display of readings and alarms
- For on-site calibration and configuration
- Different housing materials



[krohne.link/
patransmitters-en](https://krohne.link/patransmitters-en)



MAC 100
Liquid analytical trans-
mitter for measurements
with sensors of the
OPTISENS portfolio



MAC 300
Liquid analytical transmitter
for measurements with
OPTISENS TSS, pH/ORP
and COND sensors



SMARTMAC 400
Control and calibration
unit for digital
SMARTPAT Sensors



SHD 200
Control unit for 4...20
mA/HART® field devices

Analytical accessories

For liquid analytical sensors



Junction boxes
For connecting SMARTPAT
sensors to a control system



Indicators
For SMARTPAT sensors

Highlights

- Loop powered indicators
- Junction boxes, interface cables for offline calibration and other equipment
- Consumables



[krohne.link/
paaccessories-en](https://krohne.link/paaccessories-en)



Consumables
Calibration, reference
and storage solutions
for analytical sensors
and systems



Interface cables
For offline configuration and
calibration of 2-wire HART®
devices

Manual retractable assembly
for a pH sensor
in a chemical plant





Communication technology

Drivers · Protocols · Configuration · Diagnostics

Access to all assets

We are committed to making communication convenient. Which is why our field devices communicate reliably with controllers, control systems and PCs, and can also be used for a variety of control and regulating tasks.

Fast and convenient access to process and device data from any level



Cloud-based or on-premises data products



OPC UA
PA-DIM

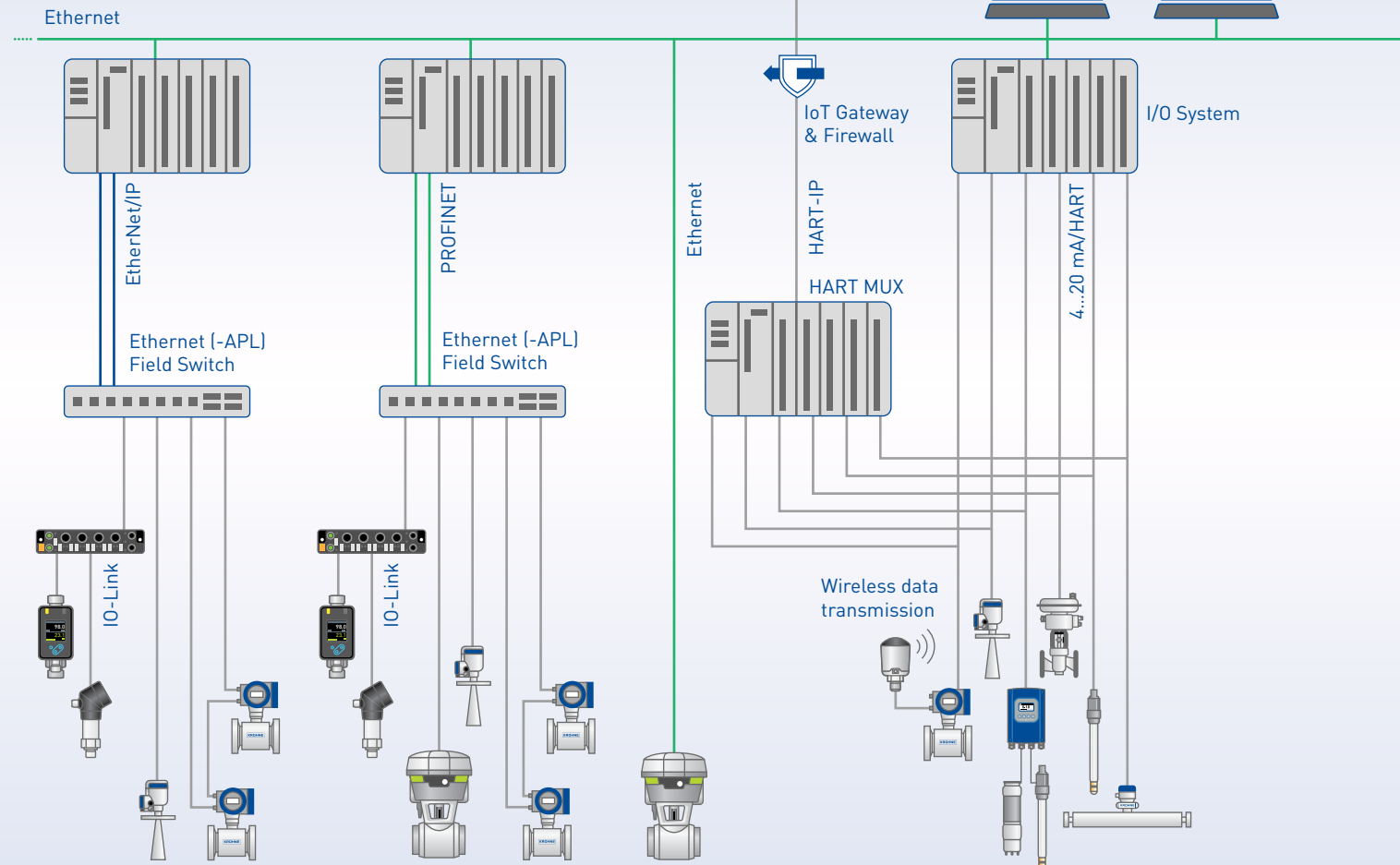
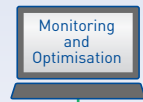
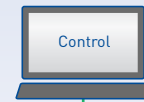

Our aim is to provide you with full and convenient access to all assets: this includes not only the measurement data, but also device configuration, status information, and additional data delivered by the field instruments.

Protocols and interfaces

We support proven and established protocols as well as new ones for certain industries, e.g. EtherNet/IP™ for the food and beverage industries, or PROFINET® for the water and wastewater sector.

Device integration

KROHNE meets all of the prerequisites for integration into modern plant asset management systems, based on integration technologies such as DD/EDD and FDT/DTM.

We are a longstanding member of PACTware™ and the FDT Group®. Since 2003, we provide DTMs and EDDs for our field devices with HART®, PROFIBUS® or FOUNDATION™ fieldbus interfaces.

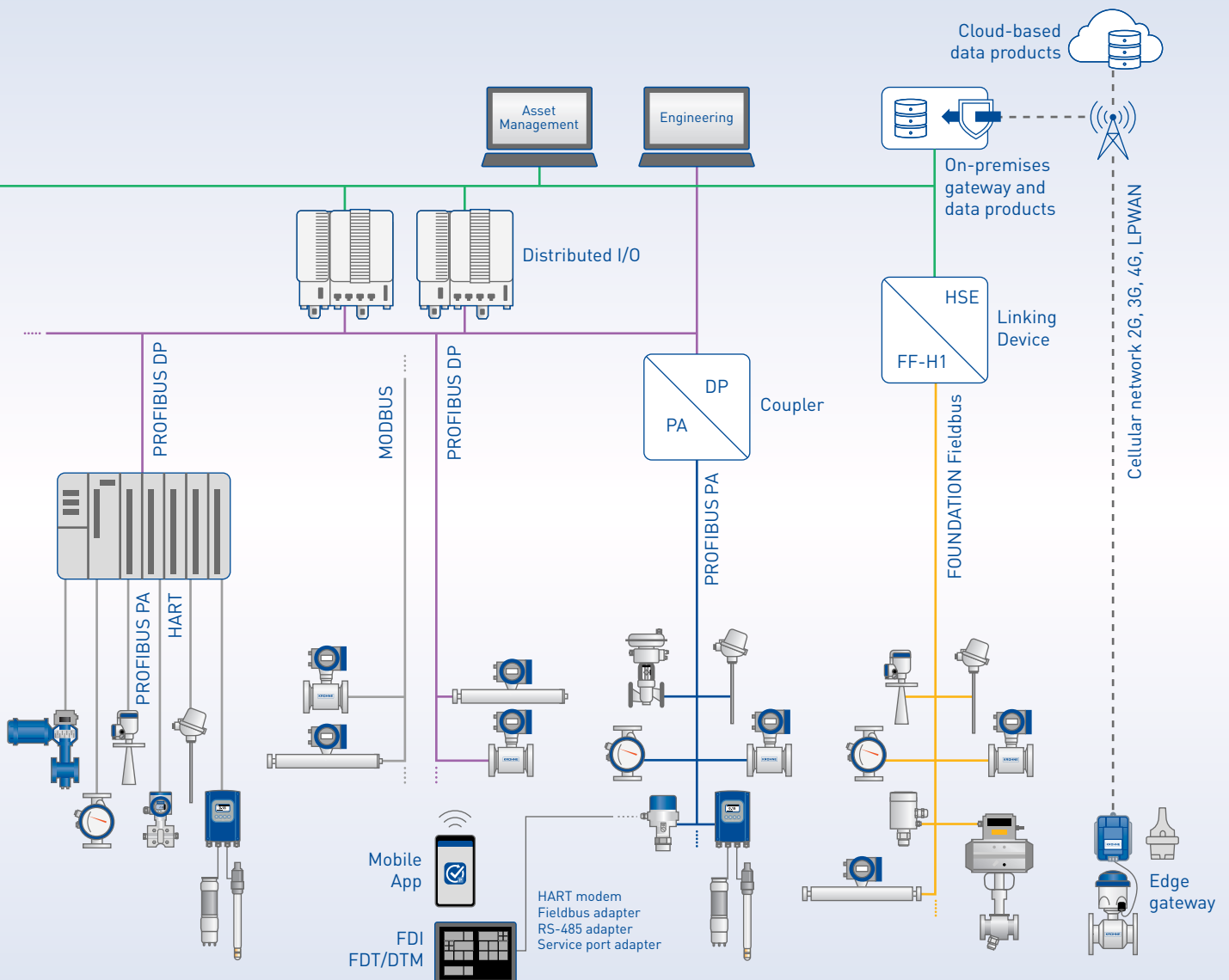

Solutions

Flow metering solutions · Monitoring solutions ·
Wireless and remote metering solutions



Engineered solutions for process control and automation

KROHNE Solutions provides engineered turn-key solutions for process control and automation – worldwide. Our portfolio ranges from single flow computers to complete skids, and from instrument management software to metering and full monitoring solutions, such as our leak detection systems (LDS) for pipelines. Our full 360-degree service concept guarantees smooth and continuous operation in the field. From first consultancy to commissioning, we take over the responsibility for the whole project lifecycle.

Our specialists are dedicated to guaranteeing benefits across the entire value chain of our customers. KROHNE supplies solutions that improve sustainability and efficiency in various segments, even covering demanding applications in the field of renewable energies like hydrogen and carbon capture, and traditional industries such as chemical, oil & gas, power generation, marine and water & wastewater.

Solutions

Flow metering solutions

- 52 Metering systems
- 52 Metering control systems
- 52 Wet gas and wellhead flow measurement
- 52 Sampling and analyser systems
- 53 Provers and master meters

Monitoring solutions

- 54 PipePatrol Pipeline Management
- 55 Supervisory and validation software
- 55 EcoMATE™ Fuel and emission monitoring for seagoing vessels
- 55 CARGOMASTER® Onboard tank monitoring and valve remote control system

Wireless and remote metering solutions

- 56 Bulk water measurement with remote data communication
- 56 Sludge level measurement with remote data communication
- 57 Level measurement with remote data communication
- 57 Measurement of disinfectants with remote data communication



krohne.com/en/solutions

KROHNE
Solutions

Flow metering solutions

Metering skids, control systems, analyser solutions



CT metering systems for LNG, hydrogen, crude oil, produced water, etc.



Geothermal steam measurement system



WGS Wet gas measurement system



Analyser house

Metering systems

Flow metering systems designed, built and commissioned in house

- Comprising flow metering skid, metering control cabinets, sampling and analyser systems, and all supervisory and validation software
- Completely pre-assembled, configured and factory tested before shipment
- Based on ultrasonic, Coriolis, turbine or DP flowmeters depending on your application

Metering control systems

Complete solution for process control and measurement

- From cost-effective flow computer solutions to custom-designed redundant metering houses
- Measurement and display of different liquid and gas streams combined on a single flow computer
- In-house expertise to discuss custody transfer approvals with local metrology offices

Wet gas and wellhead flow measurement

Measurement solutions for enhanced reservoir management

- Venturi based wet gas measurement solution; no radioactive source needed
- Real-time well performance verification for a faster decision-making process
- Coriolis based solutions for single phase and multiphase measurement, meter maintains operation over a wide range of gas fractions and complex flow conditions

Sampling and analyser systems

Measurement of product quality, water content and calorific value

- Fully automatic analyser systems combining multiple quality measurements
- In-line, fast-loop (with or without jet-mixing) and portable sampling systems
- Completely assembled, configured and tested before shipment



Monitoring solutions

Process monitoring, analysis, validation and supervisory



PipePatrol Pipeline Management

Smart monitoring and protection of pipelines

The comprehensive suite of modules for leak, theft and line break detection, plus monitoring of tightness and lifetime stress offers you a complete and sensitive protection of oil, gas, water and multiproduct pipelines, from single software applications to full packages including instrumentation.

- **PipePatrol Leak Detection**, the E-RTTM (Extended Real Time Transient Model) based leak detection and localisation
- **PipePatrol Health Check**, the complete audit of all areas of leak detection on an operator's pipeline or pipeline network
- **PipePatrol Theft Detection**, the fast and reliable identification and localisation of unauthorised or illegal product discharges
- **PipePatrol Line Break Detection**, the efficient and instant detection of pipeline ruptures
- **PipePatrol Predictive Modeling**, the simulation tool to predict pipeline conditions from current operating and manually definable static data
- **PipePatrol Batch Tracking**, the solution for batch and interface tracking in multi-product pipelines
- **PipePatrol Tightness Monitoring**, the solution for detection of small and gradual leaks
- **PipePatrol Stress Monitoring**, the solution for the evaluation and documentation of pipeline lifetime stress
- **PipePatrol Pump Monitoring**, the control cabinet solution for monitoring pumps and motors
- **PipePatrol Cyber Security**, complementing solutions for pipeline monitoring and protection against cyber risks
- **PipePatrol Data acquisition**, reliable systems for data acquisition and transmission and components for data encryption

Supervisory and validation software

Solutions for validation, visualisation and metering supervisory

- Software platforms for instrumentation and analysers
- State of the art HTML5 secure web technology
- Easy integration into existing DCS and ERP networks
- Automated instrument validation and statistical process control according to international standards

EcoMATE™ Fuel and emission monitoring for seagoing vessels

- Onboard monitoring and reporting of fuel consumption and key emission data
- MRV compliant and verified acc. to EU regulation 2015/757
- Bunkering verification: monitoring and reporting of bunker quantities in loading lines
- Cloud-based centralised web reporting tool for vessels running
- Fleet wide overview of vessel CII rating

CARGOMASTER® Onboard tank monitoring and valve remote control system

- Proven system, compliant with relevant marine regulations and accurate readings from all tanks onboard
- System software and instrumentation adapted to individual vessel applications
- Complete solution from engineering and documentation to on-site commissioning



CalSys Analyser
Management software



EcoMATE™ CII ranking
emission monitoring

Case study

Leak detection on a CO₂ pipeline via PipePatrol

- A pipeline leak detection system based on E-RTTM (Real Time Transient Modelling) supporting the safe management of the CO₂ transport pipeline's operations. In case of a leak, whether spontaneous or a small creeping leak, PipePatrol alarms the customer.
- The E-RTTM based leak detection system is based on measurement at inlet and outlet of the pipeline, and its digital twin. The system calculates the flow, pressure and temperature at any given position.
- In case of deviations from the actual measured value, a proprietary algorithm developed to avoid false alarms is used to distinguish a true leak. The project involved specific thermophysical properties of CO₂ in the supercritical phase and the flow measurements performed by orifice plates with limited rangeability. Still, the minimum detectable leak rate in this project is around 1% with a detection time of less than 15 minutes.
- A simulated leak test was carried out under 3rd party review, by setting off the reading in the SCADA system of one of the flowmeters with 10 kg/s, resulting in a swift leak alarm from PipePatrol.
- KROHNE's SynEnergy supervisory software has been used for interfacing with the existing SCADA systems and creation of the leak detection HMIs. Running on a virtual server inside the company network, the HMI screens are accessible from anywhere in the network.

Wireless and remote metering solutions

Remote data transmission for special applications

Bulk water measurement with remote data communication

Measurement solutions for water abstraction and distribution

- Remote monitoring of abstraction wells and drinking water supply lines without power supply
- Wireless connection of battery or mains powered flowmeters to a control room
- With a wide range of data transfer options for analogue or digital signals via GSM/GPRS

Sludge level measurement with remote data communication

Measurement solutions for scraper bridges and sedimentation tanks

- Remote monitoring and control of sludge blanket, sedimentation profile or fluff levels
- Continuous communication of data and simple I/O signals to a control room
- Data transfer options for each network size and distance

Sludge level measurement



Level measurement with remote data communication

Measurement solutions for tanks and other containers

- Remote monitoring of level applications over long distances
- FMCW radar level measurement with licence-free transmission system
- Continuous communication of analogue and digital signals



Level measurement with remote data communication

Measurement of disinfectants with remote data communication

Measurement solutions for chlorination and other disinfection processes

- Remote monitoring and control of drinking water disinfection
- Wireless communication of data and measuring values for dosing of Cl_2 , ClO_2 or O_3
- Connecting remote measuring points to a control room



Measurement of disinfectants with remote data communication

Services

Core services · Support & training · Spare parts & repairs ·
Premium options · Service level agreements



KROHNE Service – By your side, every step of the way

Service has been always a fundamental part of the KROHNE business and its relation with its customers. Over many years, KROHNE has developed strong service capabilities to provide excellent support throughout the entire project lifecycle.

In close cooperation with our customers, we developed a sophisticated service portfolio ensuring optimal efficiency from first planning to operation and maintenance.

Certified KROHNE owned companies as well as selected partners are organised in regional service hubs to provide our customers excellent local technical support in more than 100 countries around the world.

KROHNE
Service

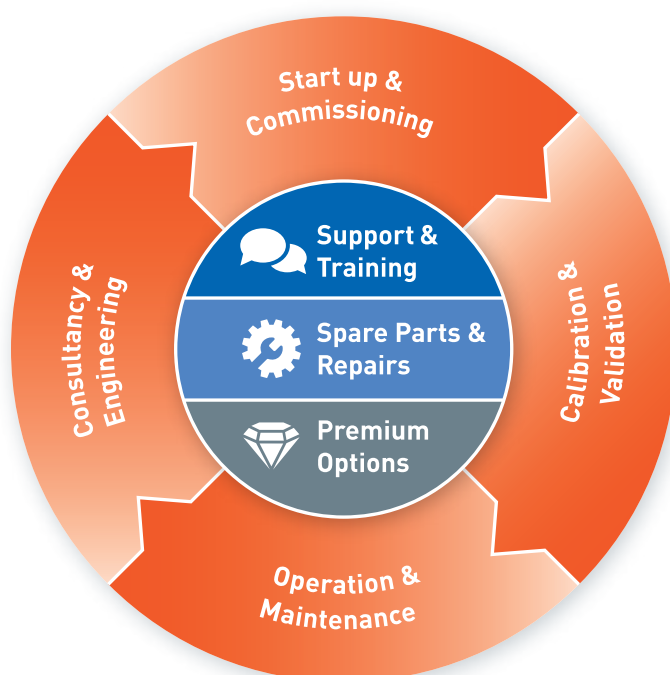

KROHNE Service portfolio over the complete project lifecycle

60 Core services

60 Consultancy & engineering
Pre-sales support starting at the planning phase and engineering through to final quotations and technical details

61 Start-up & commissioning
Assistance and commissioning, FAT / SAT support, plant / site audits and remote start-up support

62 Calibration & validation
Periodic inspection, validation, calibration, including environmental and metrological certification

63 Operation & maintenance
Scheduled maintenance and field services, on-site assistance and troubleshooting

64 Support & training
Maximise uptime and process efficiency with different service helpdesk options and trainings, starting from online courses through to tailor-made in-house workshops

65 Spare parts & repairs
Local spare parts supply & management and various repair or replacement options to solve any issues as they appear

65 Premium options
Customised services for specific customer needs including express services, exclusive support options & trainings, expert audits and priority treatment

65 Service level agreements





Core services



Consultancy & engineering

Starting right at the planning phase of any project requiring sophisticated measurement equipment, KROHNE offers comprehensive consultancy services regarding any legal aspects right through to the choice of the most efficient measurement solution. In engineering, it is imperative to consider legal requirements in particular, i.e. for any custody transfer measurement tasks or functional safety loops.



At a glance

- Interactive online configuration of measurement equipment
- Analysis of your process applications
- Personnel configuration support
- Support with the creation of planning documentation (tenders, diagrams, communication)
- Custody Transfer (CT) support
- CFD simulations
- Scope planning and definition
- Cost estimates and budgets
- Development of a project plan
- Planning of quality standards and risk identification

Start-up & commissioning

Wherever KROHNE instrumentation is installed, we will be there to provide the best possible service, from on-site analysis and workflow recommendations through to installation and commissioning.

Any measuring instrumentation operating at its optimum makes an important contribution to the performance of your installation. With further analysis and support, KROHNE can help prevent deviations which may disrupt your process, thus saving you time and ultimately money.

At a glance

- Start-up assistance
- FAT / SAT support
- Plant / site audits
- Online services for product information, commission, device configuration and parameterisation



PACTware and FDI (Field Device Integration)

KROHNE supports all common device configuration options, such as Device Descriptions (DDs and eDDs), FDT (Field Device Tool) and FDI (Field Device Integration).

Additionally, KROHNE offers DTMs (Device Type Managers) as free downloads from the KROHNE Download Center.



PICK Product Information Center

The PRODUCT INFORMATION CENTER supplies device-specific documents on the basis of the serial number.

The following document types are available:

- Manuals
- Handbooks
- Quickstart manuals
- Supplementary manuals
- Calibration certificates
- Factory settings as .bin file
- Parameter datasheets
- Type plates



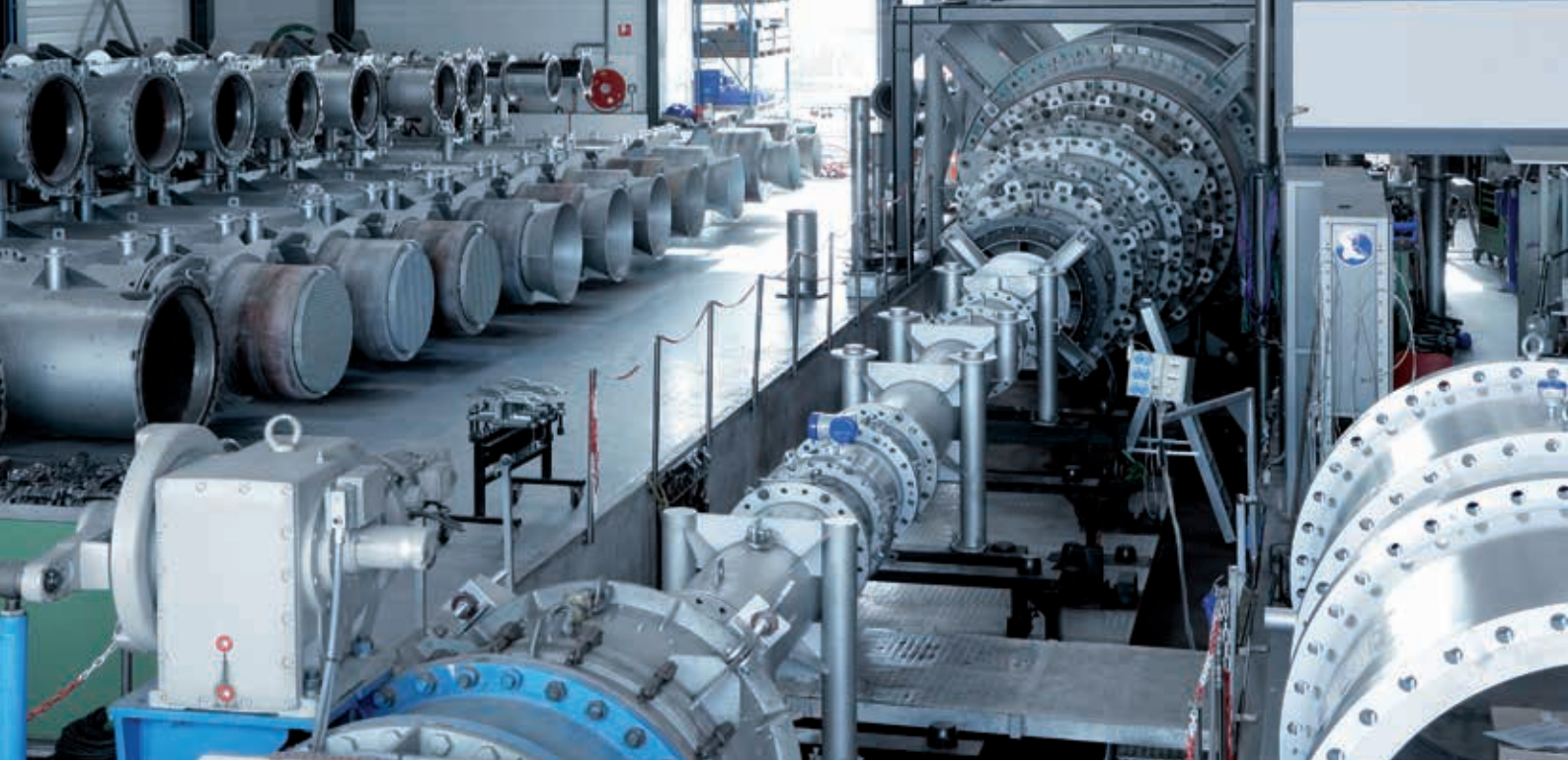

The world's most precise volumetric calibration rig for flowmeters up to DN3000/120"

Calibration & validation

Calibration is one of KROHNE's core areas of expertise. If you buy a KROHNE product, you will get a measuring device that performs most accurately under real process conditions. To achieve this, we operate more than 140 facilities to (wet-)calibrate any device we manufacture. KROHNE calibration rigs are certified according to (inter)national metrology standards.

KROHNE also offers additional on-site or laboratory calibration. This includes adjustments according to the application requirements and uncertainty calculations with all parties involved. The service is complemented by KROHNE certified validations with full audit trails, additional diagnostics and monitoring to achieve full performance. Periodical inspection includes environmental and metrological certification.

Service tools

Little helpers with a big impact

myDevice – Smart service tools

myDevice comprises different smart service tools for the complete lifecycle of a measuring point:

- Wireless parametrisation and commissioning of field devices
- Verification with highest test depth without process interruption
- Reliable information on device health
- Detailed reports for proof test documentation of safety loops (IEC 61508, 61511)
- Device-specific assets via serial number or AutoID acc. to DIN SPEC 91406
- Step-by-step video tutorials
- 24/7 online course availability



krohne.com/mydevice



Operation & maintenance

On-site field services play a crucial role in successful plant operation. Instrumentation support is often needed at short notice, especially in remote areas. KROHNE can assist with anything from simple troubleshooting of instruments to optimising complete measuring systems.

To guarantee complete availability of well-trained KROHNE service engineers, a global network of factories and service hubs has been established. Equipped with mobile installation, verification and repair equipment, KROHNE offers the full range from on-site analysis and workflow recommendations.

At a glance

- On-site assistance, planning and assessment for the best measurement solution
- Remote services, revamps and troubleshooting
- Field service training for operating and maintenance staff
- Renewal of local custody transfer approvals (e.g. in acc. with MID)
- Support on offshore facilities incl. instrumentation upgrades and retrofitting

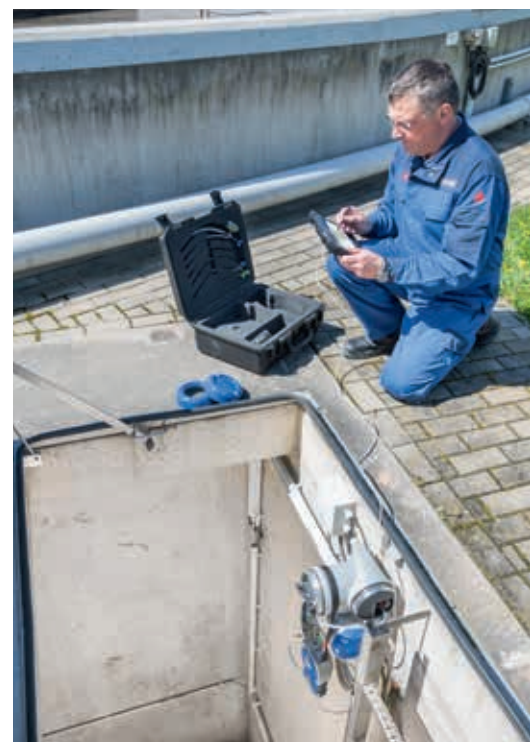

Online configuration, pricing and ordering

KROHNE offers different tools for product selection and ordering

- Easy to use device configuration and quotation
- Prices and delivery times
- Online selection of any spare part needed
- CAD models (IGES / STEP, DWG)
- Calculation of flowmeter specifications based on given process conditions
- Comparison of measuring principles and meter types and sizes
- KROHNE eShop including free shipment (limited to specific products and countries – please contact us to check local availability)





Support & training



KROHNE Academy

KROHNE Academy comprises a series of seminars organised in collaboration with leading companies in process automation. It addresses key operational topics, from plant safety to efficiency. Should your interest be more towards working “hands-on” with our devices, then our Service Academy is what you are looking for.

KROHNE Academy online is an online eLearning platform focusing on industrial process instrumentation. It comprises full audio content, explaining measuring technology without relating it to specific manufacturers. Register now for free and start your training at



academy-online.krohne.com

Tailormade workshops

To fully address individual training needs, KROHNE organises tailormade training sessions at any time, virtually anywhere in the world. All aspects starting from device-specific courses or legal aspects relating to custody transfer metering or functional safety (SIL) are covered.

Remote support and service helpdesks

One major part of the overall KROHNE mission is to provide the most effective support for our customers’ applications. The offering ranges from fast remote support to 1st level service hotlines and 2nd level expert support helpdesk, documentation services and expert audits.



Spare parts & repair



The KROHNE spare parts & repair services ensure its customers' assets are afforded the best availability and protection. Should any KROHNE device require repair, modification, configuration or calibration, specially trained and certified teams are available at any KROHNE production facility.

To provide the best possible supply of spare parts and an uninterrupted service, KROHNE has established various service hubs around the globe. Providing spare parts at local warehouses enables our customers to maintain operations with a minimum of maintenance effort.



At a glance

- On-site assistance, planning and assessment for the best measurement solution
- Remote services, revamps and troubleshooting
- Field service training for operating and maintenance staff
- Renewal of local custody transfer approvals (e.g. in acc. with MID)
- Support on offshore facilities incl. instrumentation upgrades and retrofitting



Premium options

As an addition to the comprehensive service portfolio, we offer customised premium services over the complete project lifecycle. These extended support options include offerings such as express services, priority treatment, exclusive trainings, expert audits and live video support.

At a glance

- Express service
- Express parts delivery
- Equipment rental
- On-site equipment handling
- Priority treatment
- Instant support via VIP hotline and live video support
- Customised trainings
- Specialised audits



Service level agreements

The KROHNE Modular Service Concept provides a customised approach, whereby customers can choose from a broad range of services and combine them in a way that best suits their specific, individual needs.

The concept is based on four pillars, all with the aim of maximising system and plant uptime. The core services include everything related to the normal operation of a plant, from start-up and commissioning to maintenance. The offer is accompanied by spare part & repair services to solve issues whenever they occur and various support & training options to minimise potential failure occurrence and to maximise uptime and process efficiency. In addition, KROHNE provides its exclusive premium support with many different priority options and VIP services.

Offering three different service levels for a high flexibility





Service Level Agreements



Terms & Conditions

Offering transparent choices of standard and customised terms & conditions

After a thorough analysis of all your process and measurement requirements, our service team can make an individual proposal of a service contract with several optional components. You can choose from three different service levels, depending on your individual support requirements. In addition, our transparent choices of standard and customised terms and conditions provide you with the necessary flexibility to choose the optimal service agreement for your particular needs.

	Essential Care	Advanced Care	Ultimate Care	
 <p>Core Services</p>	Pre-Sales support & consultancy	✓	✓	✓
	Start up & commissioning	✓	✓	✓
	On-site verification	—	optional	✓
	On-site service	optional	✓	✓
	Preventive maintenance (on-site & remote)	optional	✓	✓
	System validation (solutions only)	optional	optional	✓
 <p>Support & Training</p>	Standard training	✓	✓	✓
	Remote support	✓	✓	✓
	Service hotline (1 st level)	✓	✓	✓
	Expert support helpdesk (2 nd level)	✓	✓	✓
	Documentation services	✓	✓	✓
	Expert audits	optional	optional	✓
 <p>Spare Parts & Repairs</p>	Spare parts management	—	—	✓
	Repair / Calibration	optional	optional (with discount)	optional (with discount)
	Update / Upgrade services	—	optional (with discount)	optional (with discount)
	Wear parts / consumables management	—	—	optional
 <p>Premium Options</p>	Express service	—	—	✓
	Cyber security (solutions only)	✓	✓	✓
	Express parts delivery	—	optional	✓
	Equipment rental	optional	optional	✓
	On-site equipment handling	—	—	optional
	Priority treatment (“VIP Service”)	✓	✓	✓
	Live video support	—	optional	✓
	Exclusive (customised) trainings	—	optional	✓
	VIP hotline / instant support	—	optional	✓
	Specialised audits	optional	optional	optional



Water & Wastewater



From generation of tender documents to remote monitoring of measurement points

The provision of reliable water supply and sustainable wastewater treatment are essential for the development of entire regions. At the same time, operators focus on efficiency without neglecting process safety and availability.

Here, our dedicated industry division contributes the essence of over 50 years of experience and application know-how we have gained in the water and wastewater industry. We provide highly sophisticated, market oriented and competitively priced measuring devices, matched and fully equipped solutions up to integration into the control system, complemented by extended services and support.

Our team comprises consultant engineers and specialists who assist you from early planning stages to commissioning. Together with automation partners we offer trainings and (in-house) seminars.



Radars level measurement of water basin



[krohne.link/www-en](https://www.krohne.com/en)

Products

In 1961, KROHNE introduced the worlds first electromagnetic flowmeter (EMF) for water, wastewater, additives and sludge. Since then, we have developed a large and dedicated portfolio with approvals from potable water to Ex:

- FOCUS-1: first smart meter valve for measurement and control tasks on elevated tanks
- (Battery powered) electromagnetic water meters up to DN3000/120" with extended functionality e.g. to gain additional parameters or for use in leakage detection
- Dedicated flowmeters for partially filled pipes, biogas, etc.
- Level transmitters for open or closed vessels of any size
- Analytical sensors and systems for process monitoring and quality control
- Electromagnetic flow measurement as a control variable for automated cleaning of screenings and grit washers

Solutions

We have developed numerous system solutions for typical applications that have their very own requirements, e.g.:

- Custody transfer metering systems for produced water
- Bulk water metering with remote data communication
- Sludge level measurement on scraper bridges with remote data communication
- Level measurement on tanks with remote data communication
- Chlorine/disinfectant measurement in outlets of waterworks with remote data communication
- Pipeline management and leak detection systems
- Remote monitoring of water wells without power supply
- Potable water consumption monitoring and water loss detection

Services

We offer a variety of services to assist you in all stages of your water or wastewater project:

- Internet-based Planningtool: easy creation of precise tender documents (Word, Excel or GAEB) for flow, level, analysis, pressure and temperature instrumentation, combined with comfortable configuration of the devices. Find the free tool at <http://planningtool.krohne.com/>
- Periodic re-calibration of water meters and metrological services
- In-house trainings or free KROHNE Academy seminars on automation topics such as energy efficiency in water&wastewater plants, metrological requirements, dimensioning of devices, and many more.



Flow measurement of wastewater in partially filled pipes



Custody transfer metering systems for produced water



Battery-powered IP68 metering point with GSM/GPRS communication



Planningtool for generation of tender documents



Chemical

Highly concentrated know-how for your process

KROHNE
Chemical



krohne.link/chemical-en

The chemical and petrochemical industries form the foundation of the manufacturing industry. KROHNE has actively supported these industries for almost a century: we have implemented industry-specific standards and requirements regarding Exproof, resistance against chemical attack, corrosion and abrasion resistance, or plant safety.

Our specialised team brings their experience and extensive knowledge to the table: we have continuously contributed ingenious and reliable measuring technology, making processes more efficient, more reliable and more economical.

Case study

Establishing energy efficiency in a chemical plant

- Accurate flow measurement of superheated steam with OPTISONIC 8300 ultrasonic flowmeter with a 10" diameter and a 10" ASA 300 lbs connection
- Improvement of measuring accuracy and enhancement of process safety results in the reduction of energy consumption, which was linked to the pressure loss of the previous measuring devices
- Long-term stable and reliable measurement due to integrated meter verification, which means no regular maintenance is required and the self-diagnostics of the meter guarantee smooth and continuous functioning of the device



Products

As a preferred full scope supplier for many international chemical and petrochemical producers, we have developed a large product portfolio:

- Broad application range, e.g. cryogenic & high temperature applications -200...+400 °C /-328...+752 °F with a standard device
- EMF with oxide ceramics measuring tube for aggressive and abrasive products, capacitive pickup option
- Coriolis meters with straight and bent tube designs, secondary containment, tantalum option
- Wide range of devices for safety-related applications: FM, CSA, ATEX, IECEx, NEPSI, cFMus, NAMUR compliant, SIL2/3, etc.

Solutions

Based on application know-how gained over decades, we offer measuring solutions ideally suited for the challenges of the chemical industry:

- Entrained Gas Management EGM™ for Coriolis meters: significant improvements with plant start-up and shut-down, full-empty-full applications, uninterrupted output signal, etc.
- Pipeline leak detection and localisation system for liquid and gas, continuous and durable monitoring during all operating conditions, new or retrofit, multiproduct
- Metering systems for liquids and gases, mobile or stationary, e.g., tanker loading, custody transfer, batching/blending
- FOCUS-1: the first smart meter valve for flow and decentralised process control combining valve, flowmeter, pressure transmitters, temperature sensors and unique diagnostic and control functions in a single device

Services

Chemical and petrochemical facilities and processes are becoming increasingly complex and extensive: therefore, our service does not start at the first maintenance or repair call, but with the initial contact, and across the entire life cycle of the plant:

- Project management, commissioning, training and documentation
- Metrological accreditation of custody transfer applications according to Measurement Instruments Directive, OIML
- Customer inspections (FAT, SAT, TPI), pre-manufacturing (PMM) and pre-inspection meetings (PIM), quality audit support
- On-site calibration verification and documentation, calibration of devices, temporary measurements
- Seminars and workshops on relevant topics: Functional Safety, virtual grounding, diagnostics, etc.

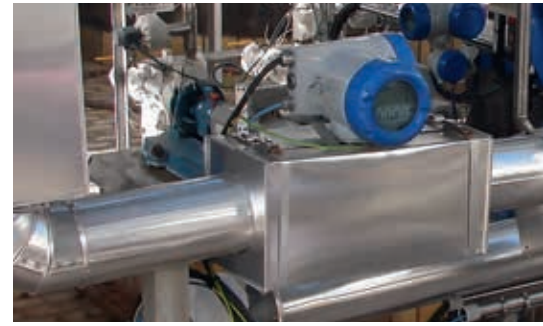

Flow and concentration measurement for dilution of sulphuric acid



Flow measurement of natural gas and oxygen for combustion control



Skid for modular fuel and combustion control



FOCUS-1 Smart meter valve for flow and decentralised process control



Food & Beverage

Optimisation in hygienic processes through key technologies

KROHNE

Food & Beverage



krohne.link/food-en

KROHNE offers measurement solutions for nearly all manufacturing processes in the food & beverage industry, including the production of beer, bread & cake, butter & cheese, chocolate, fruit & vegetable juice, grain, ice cream, liquid milk & cream, vegetable oil, pet food, soft drinks, sugar and plant-based food.

Our dedicated Food & Beverage division comprises a global team of industry specialists and account managers to take care of all individual needs of our clients. Being an instrumentation supplier for the food and beverage industry for over 20 years, we have gained industry- and application-specific know-how that we implement in our devices and measuring solutions.



Temporary flow measurement with clamp-on flowmeter in a dairy



Level measurement on a milk tank

Products

We offer a complete portfolio for flow, level, pressure and temperature measurement as well as inline analysis for hygienic and auxiliary applications. The hygienic instruments feature conformity to EC 1935/2004 and FDA, GB 4806 and are EHEDG and 3A approved.

- Flowmeters for low conductive liquids and liquids with gas entrainments
- Mass or volume flowmeters for filling machines
- Non-contact level measurement of liquids and solids, also in dusty atmospheres without air purge
- DN2.5...150/0.1...6", wide range of hygienic connections
- Best-in-class inline density measurement: 0.2 g/cm³
- Entrained Gas Management EGM™ technology: reliable measurement of mass, density, and concentration of air-containing products, e.g. with raw milk, ice cream, dough, syrup, tomato concentrate, spinach, meat, margarine, mayonnaise or plant-based food
- Handling of highly viscous media or tough, pasty or adhesive products

Solutions

Learn more about the evolution of Food & Beverage manufacturing and how measurement technology can make a difference in process optimisation: process applications from batch to inline, e.g.:

- Replacing loading cells with Coriolis flowmeters for inline weighing without process interruption
- Inline analysis of compositions, e.g. fat content in milk
- Tank level measurement solutions for the automation of storage management
- Inline density measurement of aerated products for process
- Dosing based on continuous temperature measurement to avoid overdosing of cryogenic cooling, e.g. on meat

Auxiliary applications

- Monitoring of CIP/SIP plants
- Measurement of steam, hot water, compressed air, natural gas, (thermal) oil or cooling fluids
- Gross and net heat measurement for hot water and steam with direct energy output
- Monitoring air compressor efficiency (FAD) or gas burner consumption
- MID MI-004 heat metering, supporting ISO 50001 energy management systems

Services

Our industry division team provides technical consulting, maintenance and service concepts for any plant size. We can also support you with:

- On-site verification (calibration verification and documentation)
- Calibration and metrological services
- Seminars, online trainings and configuration tools

Case study

Ice-cream production with Entrained Gas Management EGM™

Consistent product quality and overrun measurement:

- Entrained Gas Management
- EGM™ technology allows in-line density measurement after the freezer
- Maximise ice cream output based on continuous mass flow measurement and simultaneous control of air addition
- Increase product quality, eliminate sample taking, reduce freezer start-up time



OPTIMASS straight tube mass flowmeter for shear sensitive products



Oil & Gas

From well-head to refinery

KROHNE

Oil & Gas

With the oil and gas industry going through challenging times, process optimisation and cost-effective operation are now more important than ever. We understand these challenges and are helping companies to increase their efficiency by offering world class process instrumentation, metering solutions and field services to unlock the full potential of your application.

KROHNE has a vast history of supplying instrumentation and solutions in the up-, mid-, and downstream Oil & Gas industry. From wet gas solutions at the well head to enhanced solutions for blending refined products and cost-effective instrumentation to measure steam and auxiliary gases in a refinery.



krohne.link/oilgas-en

Products

We offer a large instrumentation portfolio, including:

- Process instrumentation for the entire oil & gas value chain, including flow, level, pressure and temperature measurement
- Custody transfer ultrasonic and Coriolis flowmeters for crude oil, refined products, natural gas, LNG, hydrogen and CO₂
- Wet gas flowmeters for reservoir measurement and well testing
- Multiphase and wet gas flowmeters for reservoir measurement and well testing
- Flow computers with full custody transfer approvals

Solutions

Inhouse consultancy, design and manufacturing of measurement solutions:

- Custody transfer metering systems
- Mobile master meters, ball provers and calibration systems
- Analyser houses and shelters
- Metering control systems including flow computer cabinets
- SCADA/HMI software and AMADAS analyser management
- Pipeline management and leak detection systems

Services

Our service offering covers all aspects of measurement and includes:

- Expert consultation during design phase
- Onsite commissioning and training
- Service level agreements
- Periodical inspection and validation
- Metrological accreditation according to local legal requirements
- In-house seminars and workshops on a wide range of topics



Leak detection on a multiproduct pipeline



Custody transfer flow measurement of AdBlue® from road tankers



Custody transfer flow measurement for a bidirectional natural gas border metering station

Case study

Natural gas and LNG metering systems

- For a large LNG liquefaction plant in Australia, KROHNE supplied over 20 custody transfer metering systems for natural gas and cryogenic LNG
- With system integration and instrumentation from one company, KROHNE provided a cost effective, impeccable project execution, well within customers planning



Power generation & Nuclear



Availability and safety under flexible operation

KROHNE

Power Generation



[krohne.link/
power-generation](https://krohne.link/power-generation)

KROHNE

Nuclear



[krohne.link/
nuclear-en](https://krohne.link/nuclear-en)

New sustainable power generation processes, waste heat recovery, load flexibility and denser energy grids are posing new challenges for the industry. KROHNE, with decades of experience and industry experts in power generation and nuclear, can address these challenges with industry specific products, solutions and services. References in all areas from renewables like hydropower and CSP, waste incineration, CCGT and coal plants to SMRs showcase our capabilities in this industry sector. We support processes using hydrogen as energy storage and fuel as well as the separation and storage of carbon dioxide.

As a full scope supplier, our services range from the supply of a single DP transmitter to the complete execution of project packages – such as fully engineered measurement solutions covering all project phases, through to commissioning and training. A range of unique industry-specific products and solutions for the power generation market provide benefits for both end users and EPC companies.

Nuclear projects

- Dedicated team of engineers and technicians for nuclear projects
- Flow, level, temperature and pressure range for safety-related and non-safety-related applications
- New designs or re-engineered solutions on request
- All relevant approvals and certifications for design, manufacturing and testing of instrumentation for nuclear power plants (e.g. ASME Section III, RCC-M)
- Qualifications and test reports according to IEEE 323, IEEE 344, and RCC-E for safety-related applications
- High level of safety consideration in all project procedures



TDR level measurement of condensates in irradiating environment

Products

As a leading full scope supplier, KROHNE offers established process control technologies within the specific market standards and requirements and process conditions:

- Broad range of flow, level, temperature, pressure instrumentation, fuel gas systems and custody transfer flowmeters
- ASME PTC 6 flow metering sections for performance testing via DP flow and ultrasonic flowmeters
- Dedicated certified products with resistance to radiation and/or seismic
- Mass flow and density measurement of burner fuel oil, gaseous and liquid ammonia, lime slurries and other applications
- Non-contact measurement solution for solids, bulk material and liquids
- Temperature measurements across the plant (water steam cycle, flue gas, secondary air, etc.)
- Thermowells with calculations for natural frequency, steady-state and dynamic stress analysis
- Process analytics for control and monitoring of cooling towers

Solutions

Our scope includes design and manufacturing of measuring solutions for:

- Nuclear: nuclear island systems, steam/water cycle systems, cooling systems, emergency power generation systems, auxiliary systems
- Hard coal/ lignite: storage/preparation, steam/water cycle, condensate-system, external cooling, flue gas cleaning, ash handling
- Gas/ oil: gas turbine, HRSG HP/IP/LP steam system, condensate & cooling water system, flue gas treatment
- District heating: heating network, large users
- Industrial power generation
- Waste incineration: fuel preparation, steam/water cycle, external cooling, flue gas cleaning
- Biogas: methane content, power & heat production/ efficiency monitoring, biomethane injection
- Biomass: steam, power & heat production, biomass storage, flue gas cleaning
- Solar thermal: HTF circuit, liquid salt, water/ steam circuit
- Power-2-gas: electrolysis, methanation, injection

Services

KROHNE is at your disposal with all our knowledge to help you solve these problems. With our team, we support all essential electricity generation processes:

- Project management
- Start-up and commissioning on site
- Training for customers at the nearest local facility or on site at the customers facilities



OPTIBAR DP 7060 differential pressure transmitters at a power plant



Custody transfer flow measurement for a natural gas fuel system



Level measurement of plastic waste in a waste treatment plant



Instrument commissioning carried out by a KROHNE service technician



Marine

Safe monitoring of liquids onboard all kinds of ships

KROHNE
Marine

Through our long-term and close partnerships with our customers, we have gained comprehensive knowledge, allowing us to deliver high-quality certified products, measurement solutions and services to ship owners, managers and yards. Our systems are installed in all kinds of vessels, from inland to the largest seagoing ships.

Each project is unique, with its own set of internal requirements. As a result, we provide global advice on a wide range of solutions based on the needs and operational requirements of our customers. With our in-house expertise, we offer extensive experience and knowledge in complete engineering, project management, commissioning, and training.

KROHNE Marine is certified to ISO 9001 and ISO 14001, committing to quality and environmental policy requirements.



krohne.link/marine-en

Products

We offer a large range of flow, level, temperature and pressure instruments specially designed for onboard use, e.g. with heavy-duty stainless steel housing:

- Bunkering flowmeters
- Ballast water flowmeters
- Radar (FMCW) level transmitters

Solutions

- EcoMATE™ :
 - Onboard monitoring and reporting of fuel consumption and key emission data
 - MRV ready: compliant and verified according to EU regulation 2015/757
 - Automatic calculation reporting of emission (e.g. CO₂) and efficiency data
 - Optimised for use with OPTIMASS Coriolis mass flowmeters
 - Fleet wide overview of vessel CII rating
- CARGOMASTER®:
 - Proven system, compliant with relevant marine regulations and accurate readings from all tanks
 - Complete solution of system software and instrumentation adapted to individual vessel applications
 - Flexible integration into other systems and online remote service

Services

KROHNE Marine offers a comprehensive service portfolio. Our full-service concept guarantees smooth and continuous operation of the system in the field. The services can extend from consultancy & engineering and on-site support, to maintenance and training.

- Maintenance License Agreements (MLAs) consisting of spare parts management, predictable service, remote support, priority SLA and easily accessible support hours
- Service stations worldwide for (aftermarket) support and product training, as well as online for easy error diagnosis
- Upgrades, surveying and retrofitting



Tank level monitoring on a chemical tankers with CARGOMASTER®



Fuel consumption monitoring and reporting on LPG tankers with EcoMATE™



Suction flow monitoring on dredgers

Case study Fuel balance calculation for Maersk Line

- Transfers between onboard tanks, consumption of the main engine, auxiliary engines and burners/water boilers for a vessel fuel balance calculation (marine diesel oil, heavy fuel oil and mixtures of both)
- KROHNE Marine delivered a complete measuring and monitoring solution, including system engineering, piping, mechanical and electrical installation
- After the successful POC phase, Maersk Line equipped 84 vessels of various sizes with this solution



Metal & Mining

From exploration and minerals processing to steelmaking



Mining and minerals present numerous process and operational challenges to operators in terms of maintaining measurement accuracy, reliability and asset uptime. As a long-term supplier to the mining and metal industry, KROHNE has been working with customers to drive top and bottom-line value by way of improved measurement and control, reduction of scheduled and unscheduled downtime and reduced maintenance costs.

Whether it be the exploration and processing of precious metals and coal, the inventory and distribution of bulk solids or safety critical utility applications in steel manufacture: KROHNE provides a portfolio for every facet of these industries. Our products, solutions and services are dedicated to using operating resources cost-efficiently, increasing plant uptimes, meeting high safety requirements and gaining the best possible product yield.



krohne.link/mm-en

Case study Flow measurement in hydrocyclone feedlines

Our OPTIFLUX electromagnetic flowmeters have a long track record in cyclone feedline applications. Combining abrasion resistant materials, high accuracy and repeatability, advanced diagnostics and filtering techniques, they are designed for mining slurry applications with high solid content.

Benefits for miners:

- Long-term stable flow measurement to optimise cyclone performance and maximise throughput in accordance with classification targets
- Extended meter life due to rugged, application-specific design: increase in plant uptime and significant reduction in maintenance and operating costs (OPEX)



Products

KROHNE supports metal and mining companies by applying industry-specific knowledge and process instrumentation:

- Level measurement in rock crushers, on conveyors, stockpiles, silos and bunkers, in ore passes etc.
- Flow and pressure measurement of abrasive slurries (e.g. in hydrocyclone feedlines)
- Non-radiometric concentration measurement (e.g. of tailings thickener underflow)
- Monitoring of water usage, even in remote areas without power supply
- Pit-dewatering and other wastewater disposal and mine water treatment applications
- Measurement of pH, conductivity, turbidity, dissolved oxygen and other analytes in extractive metallurgy and refining
- Utility applications (e.g. monitoring of compressed air, fresh air, oxygen or fuel gas supply)
- Temperature measurement in smelting and casting plants
- Purge-metering of protective gases and flow monitoring of coolants in high temperature applications
- Measurement of free chlorine in cooling water systems

Solutions

KROHNE offers solutions and tailored instrumentation for efficient and reliable process control from one source, e.g.:

- PipePatrol pipeline leak detection systems, incl. software, hardware, instrumentation, HMI module for high safety requirements in cooling systems of smelters, blast furnaces etc.
- Combined instrumentation for control loops, e.g. for alkalinity monitoring and chemical dosing in flotation or hydrometallurgical processes
- Engineered, fully equipped wedge flowmeters for special slurry applications
- Wireless metering solutions for monitoring of remote measuring points

Services

Through a global network of regional offices and sales representatives, KROHNE offers technical advice, delivery and service concepts for metal and mining companies worldwide, e.g.

- Pre-sales service, consultancy and engineering
- Start-up, commissioning and on-site verification (calibration verification and documentation)
- Recalibration services at one of KROHNE's certified facilities
- Training and after-sales support



Level monitoring in an ore pass



Tailings thickener underflow concentration measurement



Leak detection in cooling lines of smelters and steel works



Temperature monitoring in a continuous casting plant

H₂Hydrogen H₂

Sustainable energies

Through sustainability for a better environment

KROHNE**Sustainable Energies**

The energy sector is currently undergoing a process of change. Sustainable energies now have a firm place in today's energy mix. Supporting the energy transition and sustainability is at the top of KROHNE's agenda. As a full scope supplier, KROHNE offers a wide range of technologies for sustainable energy applications in each industry.

In addition to application know-how in the fields of hydropower, geothermal, biomass or even solar, KROHNE already has many years of experience with media such as hydrogen, carbon dioxide and biogas. Besides our product portfolio, we offer solutions such as custody transfer measurement systems and pipeline leak detection to make processes cost-efficient and safe, and to make optimum use of available resources.

krohne.link/s-energies-en

Case study

Flow measurement for billing of a hydrogen/natural gas mixture

- Custody transfer flow measurement of a gas mixture with hydrogen (H₂) and methane (CH₄)
- Re-use of existing natural gas pipeline for H₂ transport between industrial sites
- Decrease in energy consumption of 0.15 PJ, 10,000 metric tons CO₂ per year saved



Products

KROHNE offers a complete product portfolio around sustainable energies:

- Ultrasonic flowmeters for custody transfer (CT) measurement of pure hydrogen, blends of hydrogen with natural gas and biogas
- Coriolis flowmeters for custody transfer (CT) measurement of carbon dioxide in gaseous, liquid or supercritical phase
- Flow computer for custody transfer (CT) measurement approved for hydrogen applications
- Variable area flowmeters for simple and cost-effective flow measurement of gases or liquids without auxiliary power
- Process instruments for pressure and differential pressure applications
- Vortex flowmeter for utility applications and energy management systems
- Level transmitters for continuous level and interface measurement – contact and non-contact

Solutions

KROHNE supplies solutions that improve sustainability and efficiency in various segments, including demanding applications in the field of renewable energies such as hydrogen and carbon capture:

- Turnkey metering systems for water, gas, hydrogen and carbon dioxide in accordance with local metrology regulations
- Custody transfer flow computer certified for hydrogen
- Pipeline management and leak detection systems
- Wireless metering solutions for monitoring of remote measuring points
- Venturi flow metering solutions with pressure loss ratio compensation for steam applications

Services

KROHNE accompanies you from the beginning to the end of your projects and beyond. To ensure a smooth process for our customers, we are available worldwide and at any time. Our service ranges from consulting & engineering to on-site support, maintenance and training:

- Pre-sales service, consultancy and engineering
- Start-up, commissioning and on-site verification (calibration verification and documentation)
- Recalibration services at one of KROHNE's certified facilities
- Training and after-sales support



Hydrogen mass flow measurement

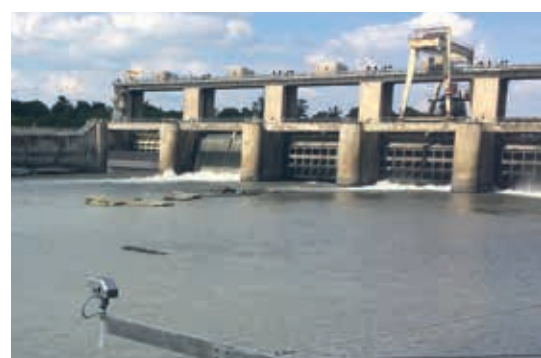

Non-contact level measurement at hydropower plant

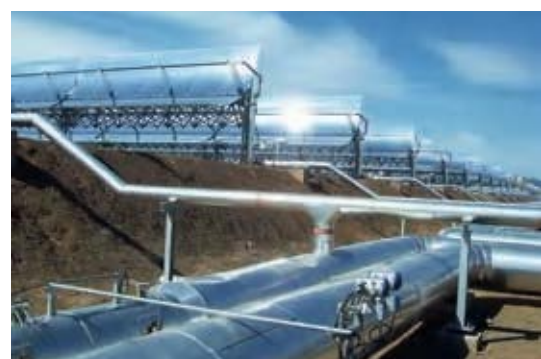

Flow measurement of thermal oil in a concentrated solar power plant



Pressure transmitter at a biomass plant

ETA Process Instrumentation

www.etapii.com

sales@etapii.com

tel 978.532.1330

New England

Martech Controls

www.martechcontrols.com

sales@martechcontrols.com

tel: 315.876.9120

Upstate New York

KROHNE – Products, Solutions and Services

- Process instrumentation for flow, level, temperature, pressure measurement and process analytics
- Flow metering, monitoring, wireless and remote metering solutions
- Engineering, commissioning, calibration, maintenance and training services

