

HALOGUARD® II

Multichannel, Multigas, Refrigerant Leak Monitor



Visit our website at:
www.thermalgas.com



Multichannel controller monitors up to six remote sensors for...

- Refrigeration Equipment
- Machinery Rooms
- Cold Storage Areas
- Process Cooling

Provides non-selective PPM detection for CFC, HFC, HCFC, and NH3 refrigerants. Optionally, reports oxygen depletion.

- Meets ASHRAE Std. 15-2013 & Canada Std. B52-95
- Reduces refrigerant loss
- Protects sensitive inventory
- Alerts service personnel
- Enables scheduled maintenance
- Features remote notification
- Controls exposure risk

THERMAL GAS *Systems* inc.
Haloguard® Monitors

HALOGUARD® II

24-Hour Multichannel Multigas Leak Detection and Notification

With dependable solid state electronics, HALOGUARD® II is a cost-effective, reliable way to detect the presence of halo-carbons, ammonia, and oxygen depletion. The multichannel, multigas HALOGUARD® II controller monitors sensors in up to six separate locations and provides both local and remote notification when gas concentration reaches an alarm level.

We've built in alarm relays and analog outputs to activate remote devices or to interface with a computer controlled energy management or building automation system.

Features

- **Up to six sensors reporting to one central controller**
- **Each sensor with 6' instrument cable and DIN plug, extendable to 300'**
- **LCD shows channel number, PPM Concentration, Alarm, Test, Reset, Sensor Fault, and Low Battery**
- **Audible alarm**
- **2 user alarms adjustable between 10% – 100% of scale**
- **Off-scale and sensor fault alarm**
- **4 alarm relays for ventilation, dialer, or remote notification**
- **4 independent analog outputs for BAS/EMS interface**
- **User selectable manual or automatic sensor scanning**
- **Adjustable sensor scan frequency**
- **Simple installation with easy field calibration**
- **Easy expansion as requirements change**
- **Built-in alarm Delay/Reset and Test push buttons**
- **Self-diagnostics for each sensor**
- **Dependable, solid-state electronics**

Options

- **Strobe light alarm**
- **Gas test kit**
- **Battery back-up**
- **Automatic calibration**

Specifications

Technology.....	CMOS
Electrical Supply.....	115-230v, 50-60Hz
Output Signal	Std: 4 x 3A, dry contact relay Opt: 4 x 0-5 VDC analog
Accuracy	10% Full-scale
Range.....	0 - 1000ppm CFC, HFC, HCFC (except R123) 0 - 300ppm R123, NH3 0 - 25% Oxygen
Response Time	<1 minutes
Clearing Time	<3 minutes
Operating Conditions:	
CMOS Sensor	-20°F to +120°F non-condensing
Controller	0°F to 120°F non-condensing
Materials:	
Sensor	PVC enclosure and PP filter
Controller	NEMA 4/12 design
Weight	8 lbs.

Warranty

Sensor element is unconditionally guaranteed for one year from the date of shipment. Any sensor found defective in that period will be replaced free of charge. Read terms and conditions of sale for complete warranty information.

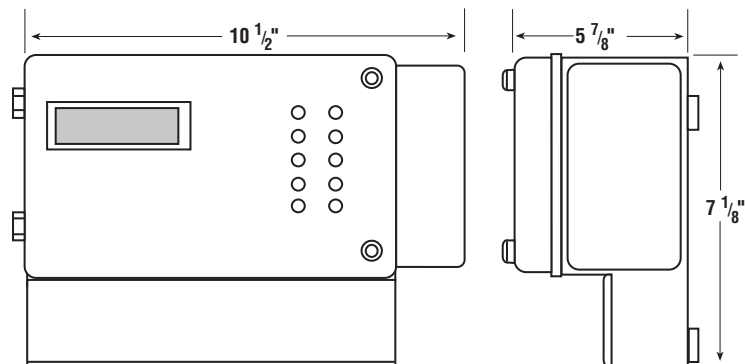

New England - ETA Process Instrumentation
119 Foster Street, Bldg #6
Peabody, MA 01960
Tel: (978) 532-1330
www.etapii.com
sales@etapii.com

Upstate NY - Martech Controls
2000 Teall Avenue
Syracuse, NY 13026
Tel: (315) 876-9120
www.martechcontrols.com
sales@martechcontrols.com