



OPTIWAVE 15XX Technical Datasheet

80 GHz radar (FMCW) level and flow transmitters

- For simple liquid and bulk solid applications
- Bluetooth® / Easy commissioning via Smartphone / Tablets or PC
- Flush-mounted PVDF Lens antenna



HART
COMMUNICATION PROTOCOL



ETA Process Instrumentation

www.etapii.com
sales@etapii.com
tel: 978.532.1330

New England

Martech Controls

www.martechcontrols.com
sales@martechcontrols.com
tel: 315.876.9120

Upstate New York

1	Product features	3
<hr/>		
1.1	Overview: OPTIWAVE 15XX series - plastic 80 GHz level transmitter	3
1.2	OPTIWAVE 1520 - simple applications	4
1.3	OPTIWAVE 1540 - high-precision applications	5
1.4	Measuring principle.....	6
2	Technical data	7
<hr/>		
2.1	Technical data.....	7
2.2	Minimum power supply voltage	13
2.3	Measuring accuracy	14
2.4	Dimensions and weights	16
2.4.1	OPTIWAVE 1520 or 1540.....	16
2.4.2	Cable clamp (accessory).....	17
2.4.3	Long bracket (accessory).....	18
2.4.4	Short bracket (accessory).....	19
2.4.5	Purging system (accessory).....	20
2.4.6	Orientation system (accessory)	21
2.4.7	Weather protection cover (accessory)	22
2.4.8	Weights.....	23
3	Installation	24
<hr/>		
3.1	Intended use	24
3.2	Pre-installation requirements	24
3.3	Installation	25
3.3.1	Pressure and temperature ranges.....	25
3.3.2	Types of installation	26
3.3.3	Positioning the device	28
3.3.4	Equipment and obstacles	29
3.3.5	Product inlets on tanks and silos	31
3.3.6	Tanks, hoppers and silos with dish-shaped or conical bottoms.....	32
3.3.7	Containers made of non-conductive materials.....	33
4	Electrical connections	34
<hr/>		
4.1	General notes	34
4.2	Electrical connection for current output	34
4.3	Networks	35

1.1 Overview: OPTIWAVE 15XX series - plastic 80 GHz level transmitter

The OPTIWAVE 15XX series is a range of reasonably priced non-contact level transmitters that use FMCW radar technology. The device housing and antenna are made of PVDF, which is compatible with almost all common products.

They can operate at temperatures from -25 to $+80^{\circ}\text{C}$ / -13 to $+176^{\circ}$ and pressures from -1 to 5 bar / -14.5 to 75.2 psi.

Operating in a frequency range around 80 GHz and with a frequency sweep of 4 GHz, these devices can measure with a high signal resolution. They comply with NAMUR Recommendation NE 107 for status and error handling and enhanced diagnostic functions are available using either the OPTICHECK Level Mobile app or a DTM for PACTware that are both supplied free of charge.



- ① PVDF, IP68-rated housing (tested at 4 bar for 48 hours)
- ② Shielded cable supplied as standard
- ③ Integrated Bluetooth® communication module
- ④ Flush-mounted DN40 Lens antenna with a small beam angle

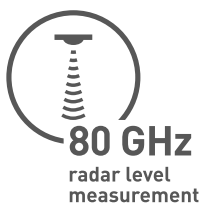

80 GHz radar level measurement

The 80 GHz technology used in the OPTIWAVE series is the most recent and versatile radar technology for level measurement of liquids and solids. Over an identical distance, it presents a highly focused beam with a smaller diameter compared to lower frequency radars, ideal for dusty atmospheres or low reflective media. The small dead zone and narrow beam angle allow for use in both small and tall vessels.



Tank Bottom Management (TBM)

TBM (Tank Bottom Management) for the OPTIWAVE radar level transmitters ensures reliable measurement even in empty tanks. Based on many years of experience and know-how with radar level measurement, KROHNE developed dedicated algorithms to filter and compensate for irregular radar wave reflections that occur in the tank bottom. This only happens when the tank is empty. TBM allows for quick and easy commissioning of tanks regardless of their size, material or geometry.

General highlights

- Two versions: 1520 (basic applications) and 1540 (high-precision applications)
- 2-wire device / 4...20 mA + HART® 7 output
- PVDF housing is compatible with most measured products
- Small dead zone and beam angle (8°)
- 80 GHz FMCW radar - high signal dynamics ensure accurate, reliable measurements
- Extensive choice of accessories: brackets, low-pressure flange, orientation kit, purging system and weather protection cover
- User interface options include:
 - **Mobile device:** OPTICHECK Level Mobile app
 - **PC:** HART DTM and Bluetooth® DTM
- Easy step-by-step device configuration
- 3-year warranty

1.2 OPTIWAVE 1520 - simple applications

The OPTIWAVE 1520 measures distance, level and volume of liquids, pastes and solids in simple applications and is particularly suitable for the water and waste water industry.

Highlights

- Accuracy: ± 5 mm / ± 0.20 "
- Lens antenna measures distances up to 10 m / 32.8 ft

Industries

- Water and waste water
- Chemical market
- Metals, Minerals & Mining
- Food & beverage

Applications

- Pumping station
- Low-pressure and low-temperature applications
- Measurement through tank roofs made of non-conductive materials (e.g., plastic, glass etc.)
- Animal feed
- Stock inventory
- Conveyor belts
- Granulates

1.3 OPTIWAVE 1540 - high-precision applications

The OPTIWAVE 1540 is calibrated to provide precise measurements of distance, level, volume and volumetric flow rate. The high dynamics of the measurement signal permits the device to accurately measure agitated product surfaces and other difficult conditions even when there is condensation on the antenna.

Highlights

- Accuracy: ± 2 mm / ± 0.08 ''
- Lens antenna measures distances up to 15 m / 49.2 ft

Industries

- Chemical market
- Water and waste water
- Metals, Minerals & Mining
- Food & beverage (solids)

Applications

- Open channels
- Combined sewer overflows
- IBC (volume measurement)
- Basin
- River
- Stock inventory (seeds, cereals etc.)

1.4 Measuring principle

A radar signal is emitted via an antenna, reflected from the product surface and received after a time t . The radar principle used is FMCW (Frequency Modulated Continuous Wave).

The FMCW-radar transmits a high frequency signal whose frequency increases linearly during the measurement phase (called the frequency sweep). The signal is emitted, reflected on the measuring surface and received with a time delay, t . Delay time, $t=2d/c$, where d is the distance to the product surface and c is the speed of light in the gas above the product.

For further signal processing the difference Δf is calculated from the actual transmitted frequency and the received frequency. The difference is directly proportional to the distance. A large frequency difference corresponds to a large distance and vice versa. The frequency difference Δf is transformed via a Fast Fourier Transform (FFT) into a frequency spectrum and then the distance is calculated from the spectrum. The level results from the difference between the tank height and the measured distance.

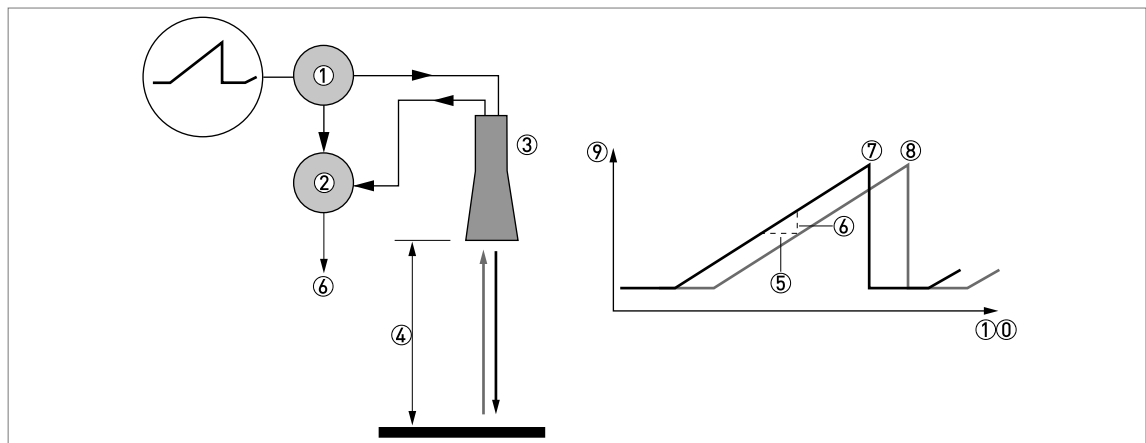

Figure 1-1: Measuring principle of FMCW radar

- ① Transmitter
- ② Mixer
- ③ Antenna
- ④ Distance to product surface, where change in frequency is proportional to distance
- ⑤ Differential time delay, Δt
- ⑥ Differential frequency, Δf
- ⑦ Frequency transmitted
- ⑧ Frequency received
- ⑨ Frequency
- ⑩ Time

2.1 Technical data

- The following data is provided for general applications. If you require data that is more relevant to your specific application, please contact us or your local sales office.
- Additional information (certificates, special tools, software,...) and complete product documentation can be downloaded free of charge from the website (Downloadcenter).

	1520	1540
--	------	------

Measuring system

Measuring principle	2-wire loop-powered level and flow transmitter; FMCW radar
Frequency range	W-band (77...81 GHz)
Max. radiated power (EIRP)	< +34 dBm according to ETSI EN 302 729, 47 CFR Part 15 (FCC) and RSS-211 (ISED)
Application range	Level measurement of liquids, pastes, slurries and granulates
Primary measured value	Distance
Secondary measured value	Level, volume and flow rate

Design

Construction	The measurement system consists of a measuring sensor (antenna) and a signal converter.	
Antenna size	DN40 (1½")	
Options	Electrical cable supplied with the housing, length Standard: 5 m / 16.4 ft Optional: 10 m / 32.8 ft, 25 m / 82.0 ft, other length (on request)	
Accessories	316L low-pressure flange disc for NPT (ASME B1.20.1) option	
	316L low-pressure flange disc for G (ISO 228-1) option	
	Cable clamp - for a device suspended from a ceiling or an overhang	
	Purging system adaptor with G 1/4 inlet ①	
	Weather protection cover	
	Stainless-steel long bracket (adjustable transmitter position)	
	Stainless-steel short bracket	
	Orientation system (max. tilt 30°) with 316L low-pressure flange disc (atmospheric pressure)	
	Stainless-steel tag plate (18 characters max.)	
Max. measuring range	10 m / 32.8 ft	15 m / 49.2 ft
Min. tank height	0.2 m / 12"	
Recommended minimum blocking distance	0.1 m / 4"	
Beam angle	8°	

	1520	1540
User interfaces		
Remote operation	OPTICHECK Level Mobile app - wireless Bluetooth	
	PACTware™ with the OPTIWAVE 15XX Device Type Manager (DTM) - wireless Bluetooth	
	PACTware™ with the OPTIWAVE 15XX Device Type Manager (DTM) - HART	
	AMS Trex™ from Emerson Process - HART DD	
	PDM from Siemens - HART DD	
Interface languages	DTM (HART), DTM (Bluetooth) and Mobile App: English, French, German and Chinese (simplified)	
	DD (HART): English	

Measuring accuracy

Resolution	1 mm / 0.04"	
Repeatability	±1 mm / ±0.04"	
Accuracy, liquids when distance ≤ 10 m / 33 ft	±5 mm / ±0.19", when distance > 0.2 m / 0.65 ft	±2 mm / ±0.08", when distance > 0.4 m / 1.31 ft
Accuracy, liquids when distance > 10 m / 33 ft	—	±0.02% of measured distance. For more data, refer to <i>Measuring accuracy</i> on page 14.
Accuracy, bulk solids	Variable. This value depends on the product measured and the application.	
Temperature drift (analogue)	Typically 50 ppm/K	
Temperature drift (digital)	< 3 mm/10 K ②	
Reference conditions according to EN 61298-1		
Temperature	+15...+25°C / +59...+77°F	
Pressure	1013 mbara ±50 mbar / 14.69 psia ±0.73 psi	
Relative air humidity	60% ±15%	
Target	Metal plate in an anechoic chamber	

Operating conditions

Temperature	
Ambient temperature	-25...+80°C / -13...+176°F Ex: see supplementary operating instructions or approval certificates
Relative humidity	RH4% to RH99%
Storage temperature	-40...+80°C / -40...+176°F
Process connection temperature	-25...+80°C / -13...+176°F
Pressure	
Process pressure	-1...5 bar / -14.5...72.5 psi
Other conditions	
Dielectric constant (ϵ_r)	≥ 2
Ingress protection	IEC 60529 IP66/67/IP68 – IP68 test conditions: 48 hours at a pressure of 4 bar / 58 psi
ESD protection	±8 kV according to DNVGL-CG-0339

	1520	1540
UV resistance	UL 746C - rating f1 (applicable to outdoor operation); ISO 4892-2 - method B; UL 1581 Sec.1200 (electrical cable)	
Flammability rating	UL 94 (enclosure, connectors and insulation material); UL 2556 VW1 (electrical cable and wires); IEC 60332-1-2	
Measuring cycle time	≥ 250 ms	
Maximum rate of change	60 m/min / 196 ft/min	

Installation conditions

Process connection size	The nominal diameter (DN) should be equal to or larger than the antenna diameter.
Process connection position	Make sure that there are not any obstructions directly below the process connection for the device. For more data, refer to <i>Installation</i> on page 24.
Dimensions and weights	For dimensions and weights data, refer to <i>Dimensions and weights</i> on page 16.

Materials

Main components	
Housing	PVDF
Wetted parts, including antenna	PVDF
Process connection	PVDF
Gasket	FKM/FPM [-15...+80°C / -5...+176°F] - only for devices with a G (ISO 228-1) threaded connection
Outer sheath, electrical cable	Polyurethane (PUR)
Housing seal, electrical cable	EPDM ③
Accessories	
Weather protection cover (option)	ASA
Long bracket	Stainless steel (316Ti) with PVC-U nut
Short bracket	Stainless steel (316Ti) with PVC-U nut
Cable clamp	Galvanised carbon steel (clamping jaws: fibreglass-reinforced PA)

Process connections

Thread	G 1 1/2 A (ISO 228); 1 1/2 NPT (ASME B1.20.1)
--------	--

Electrical connections

Power supply	Terminals output – Non-Ex / Ex mb: 12...35 V DC; min./max. value for an output of 22 mA at the terminal Terminals output – Ex i: 12...30 V DC; min./max. value for an output of 22 mA at the terminal
Maximum current	22 mA
Current output load	$R_L [\Omega] \leq ((U_{ext} - 12 V) / 22 \text{ mA})$. For more data, refer to <i>Minimum power supply voltage</i> on page 13.
IEC 61010-1 electrical data	Overvoltage category III / Maximum altitude: 5000 m above mean sea level / Pollution degree 4 / Outdoor use
Cable entry	N/A - integrated electrical cable
Cable gland	N/A - integrated electrical cable
Electrical cable diameter	6.4 mm ±0.2 mm / 0.252" ±0.008"

	1520	1540
--	------	------

Input and output

Current output	
Output signal	Standard: 4...20 mA Options: 3.8...20.5 mA according to NAMUR NE 43; 4...20 mA (reversed); 3.8...20.5 mA (reversed) according to NAMUR NE 43
Output type	Passive
Resolution	±1 µA
Error signal	High: 21.5 mA; Low: 3.5 mA according to NAMUR NE 43
HART®	
Description	Digital signal transmitted with the current output signal (HART® protocol)
Version	7.7
Load	≥ 250 Ω
Multi-drop operation	Yes. Current output = 4 mA. Enter Program mode to change the polling address (1...63).
Device drivers	Available for AMS Trex™, PDM, FDT/DTM
HART® registered	Yes
Bluetooth® interface	
Description	The interface offers wireless connectivity to the device via Bluetooth® Low Energy 5.2
Frequency range	R-band (2400...2483.5 MHz)
Max. emitted power	+6.5 dBm
Apps	OPTICHECK Level Mobile app – available for Google Android™ and Apple® iOS
	OPTIWAVE 15xx DTM – available for PACTware™ on Microsoft Windows
	Supported mobile devices must have at least the following features: - Bluetooth® Low Energy 4.0 interface or higher For the minimal supported versions of Google Android™ or Apple® iOS refer to the latest version of the OPTICHECK Level Mobile app available in "Google Play™ store" or "Apple App Store".
Effective range	50 m / 164 ft at the maximum power setting (in reference conditions)
Signal encryption	Proprietary PACE protocol based on ECDH
Functionality	Display status, measurement & diagnostic data
	Device parametrization and guided configuration wizards
	Advanced diagnostic methods

Approvals and certification

CE / UKCA	The device meets the essential requirements of the EU Directives and UK Regulations. The manufacturer certifies successful testing of the product by applying the CE or UKCA marking.
	For more data about the European Standards and UK Designated Standards related to this device, refer to the EU and the UKCA Declarations of Conformity. You can download this document free of charge from the website (Download Center).
Vibration resistance	IEC 60721-3-4 / IEC 60068-2-6 (class 4M7 / ±5 mm / 9...200 Hz); EN 61298-3 (10...58 Hz: ±0.15 mm / 58...1000 Hz: 3g)
Shock resistance	IEC 60068-2-27 (class 4M7: 25g shock ½ sinus: 6ms)

	1520	1540
Conformity to sanitary regulations (wetted parts)	Regulation (EC) No 1935/2004, Commission Regulation (EC) No 2023/2006, Commission Regulation (EU) No 10/2011	
	FDA 21 CFR 177.2510	
	GB 4806.10	
Explosion protection		
ATEX (Ex ia, Ex idb ia or Ex ia tb) EU Type Approval - pending UKEX (Ex ia, Ex idb ia or Ex ia tb) UK Type Approval - pending	II 1/2 G Ex ia IIC T6...T3 Ga/Gb;	
	II 1/2 D Ex ia IIIC T85°C...T*°C Da/Db; ④	
	II 1/2 G Ex db ia IIC T6...T3 Ga/Gb;	
	II 1/2 D Ex ia tb IIIC T85°C...T*°C Da/Db ④	
ATEX (Ex ic) Type Approval - pending	II 3 G Ex ic IIC T6...T3 Gc;	
	II 3 D Ex ic IIIC T85°C...T*°C Dc ④	
IECEx - pending	Ex ia IIC T6...T3 Ga/Gb;	
	Ex ia IIIC T85°C...T*°C Da/Db; ④	
	Ex db ia IIC T6...T3 Ga/Gb;	
	Ex ia tb IIIC T85°C...T*°C Da/Db; ④	
	Ex ic IIC T6...T3 Gc;	
	Ex ic IIIC T85°C...T*°C Dc ④	
cQPSus - pending	Division ratings	
	XP-IS, Class I, Div 1, GPS ABCD, T6...T3;	
	DIP, Class II/III, Div 1, GPS EFG, T85°C...T*°C; ④	
	IS, Class I, Div 1, GPS ABCD, T6...T3;	
	IS, Class II/III, Div 1, GPS EFG, T85°C...T*°C; ④	
	NI, Class I, Div 2, GPS ABCD, T6...T3;	
	NI, Class II/III, Div 2, GPS FG, T85°C...T*°C ④	
	Zone ratings	
	Class I, Zone 1, AEx db ia [ia Ga] IIC T6...T3 Gb (US) – antenna suitable for Zone 0; Ex db ia [ia Ga] IIC T6...T3 Gb (Canada) – antenna suitable for Zone 0;	
	Class I, Zone 0, AEx ia IIC T6...T3 Ga (US); Ex ia IIC T6...T3 Ga (Canada);	
	Zone 20, AEx ia IIIC T85°C...T*°C Da (US); Ex ia IIIC T85°C...T*°C Da (Canada); ④	
	Zone 21, AEx ia tb [ia Da] IIIC T85°C...T*°C Db (US) – antenna suitable for Zone 20 Ex ia tb [ia Da] IIIC T85°C...T*°C Db (Canada) – antenna suitable for zone 20 ④	
	NEPSI - pending	Ex ia IIC T3–T6 Ga/Gb;
Ex d ia IIC T3–T6 Ga/Gb;		
Ex iaD 20/21 T85...T*; ④		
Ex iaD 20/21 tD A21 IP6X T85°C...T*°C ④		
EAC-EX - pending	Ga/Gb Ex ia IIC T6...T3 X;	
	Da/Db Ex ia IIIC T85°C...T*°C X; ④	
	Ga/Gb Ex db ia IIC T6...T3 X;	
	Da/Db Ex ia tb IIIC T85°C...T*°C X ④	

	1520	1540
Type approvals - ships and other offshore units		
DNV-GL - pending	Location Classes - temperature: D, humidity: B, vibration: A, EMC: B, and enclosure: C	
Other standards and approvals		
Electromagnetic compatibility	EU: Electromagnetic Compatibility directive (EMC)	
	UK: Electromagnetic Compatibility Regulations	
Radio approvals	EU: Radio Equipment directive (RED)	
	UK: Radio Equipment Regulations	
	FCC Rules: 47 CFR Part 15	
	Industry Canada: RSS-211	
Electrical safety	EU: Agrees with the safety part of the Low Voltage directive (LVD)	
	UK: Agrees with the safety part of the Electrical Equipment (Safety) Regulations	
	USA and Canada: Agrees with NEC and CEC requirements for installation in ordinary locations	
NAMUR	NAMUR NE 21 Electromagnetic Compatibility (EMC) of Industrial Process and Laboratory Control Equipment	
	NAMUR NE 43 Standardization of the Signal Level for the Failure Information of Digital Transmitters	
	NAMUR NE 53 Software and Hardware of Field Devices and Signal Processing Devices with Digital Electronics	
	NAMUR NE 107 Self-Monitoring and Diagnosis of Field Devices	

Table 2-1: Technical data

- ① This option can also be attached to the orientation system
- ② If the device operates in a hot and humid area, then there can be a small, permanent measurement offset (max. 5 mm / 0.20"). If it is necessary to correct this measurement offset, then tell the supplier.
- ③ EPDM is not compatible with mineral oils
- ④ T* = 150 or 200. For more data, refer to the related Ex approval certificate.

2.2 Minimum power supply voltage

Use these graphs to find the minimum power supply voltage for a given current output load.

Non-Ex and Hazardous Location approved (Ex mb) devices

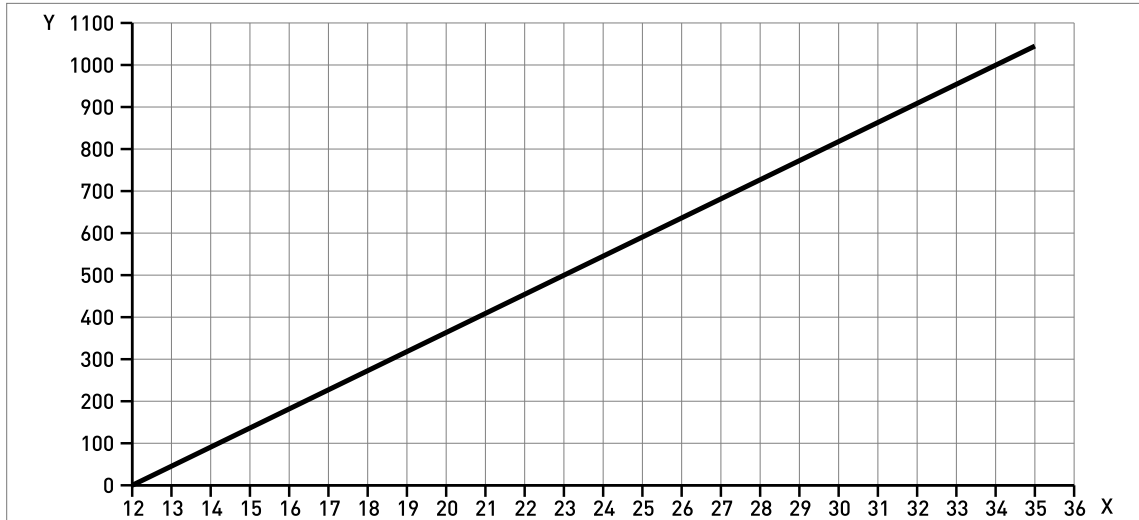

Figure 2-1: Minimum power supply voltage for an output of 22 mA at the terminals (Non-Ex and Hazardous Location approval (Ex mb))

X: Power supply U [V DC]

Y: Current output load R_L [Ω]

Hazardous Location approved (Ex i / IS) devices

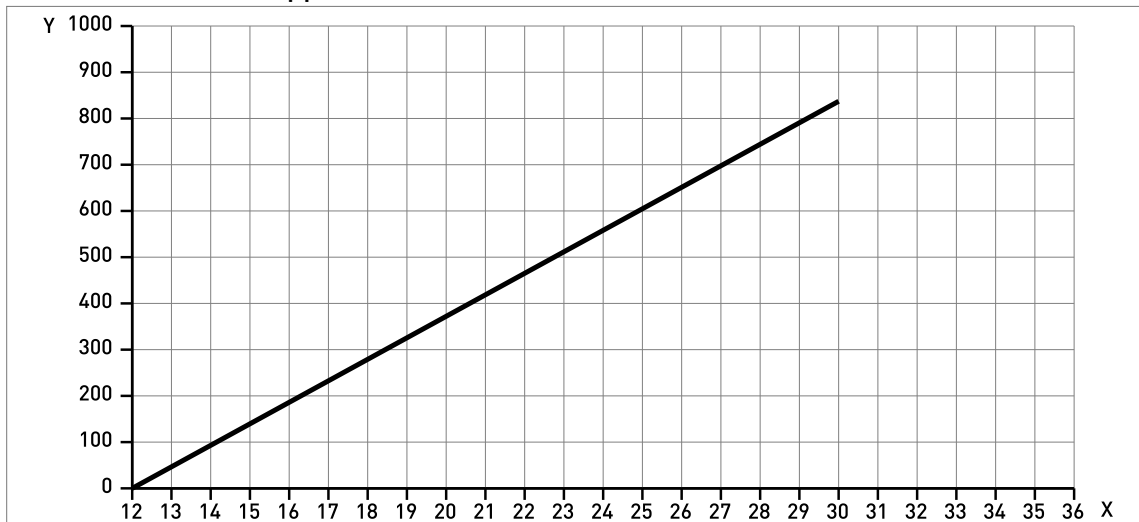

Figure 2-2: Minimum power supply voltage for an output of 22 mA at the terminals (Hazardous Location approval (Ex i / IS))

X: Power supply U [V DC]

Y: Current output load R_L [Ω]

2.3 Measuring accuracy

Use these graphs to find the measuring accuracy for a given distance from the transmitter. For a distance more than 10 m / 32.8 ft, refer to *Technical data* on page 7 (measuring accuracy).

OPTIWAVE 1520

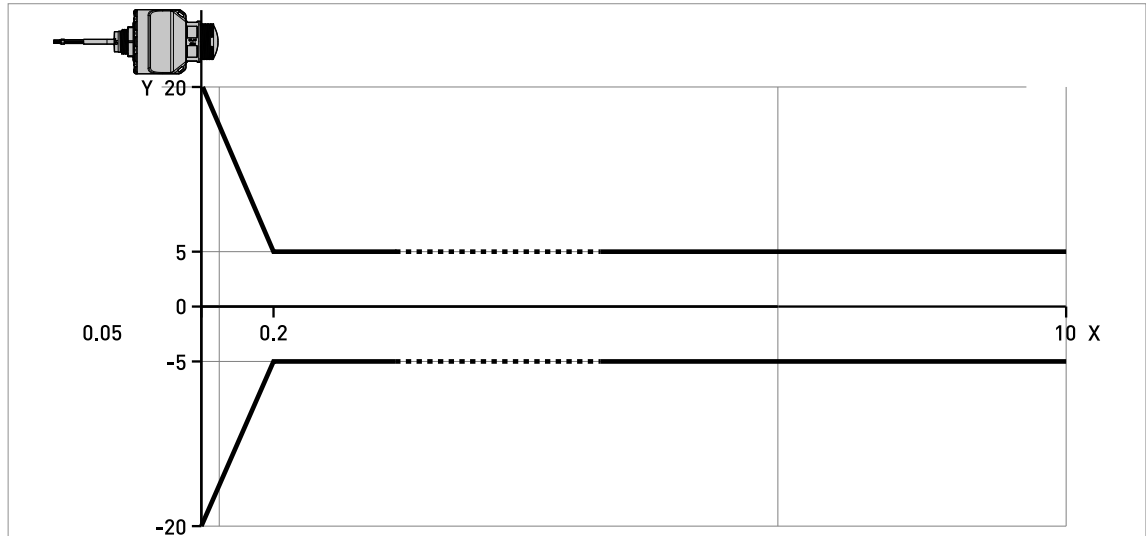

Figure 2-3: Graph of accuracy in mm against measuring distance in m

X: Measuring distance from the bearing surface of the threaded connection [m]
 Y: Accuracy [+yy mm / -yy mm]

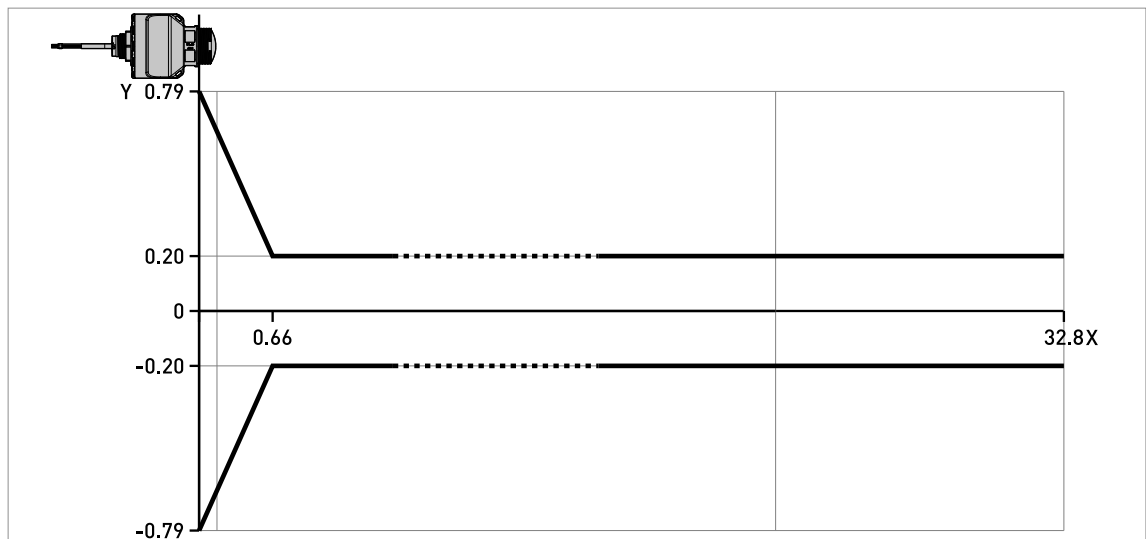

Figure 2-4: Graph of accuracy in inches against measuring distance in ft

X: Measuring distance from the bearing surface of the threaded connection [ft]
 Y: Accuracy [+yy inches / -yy inches]

OPTIWAVE 1540

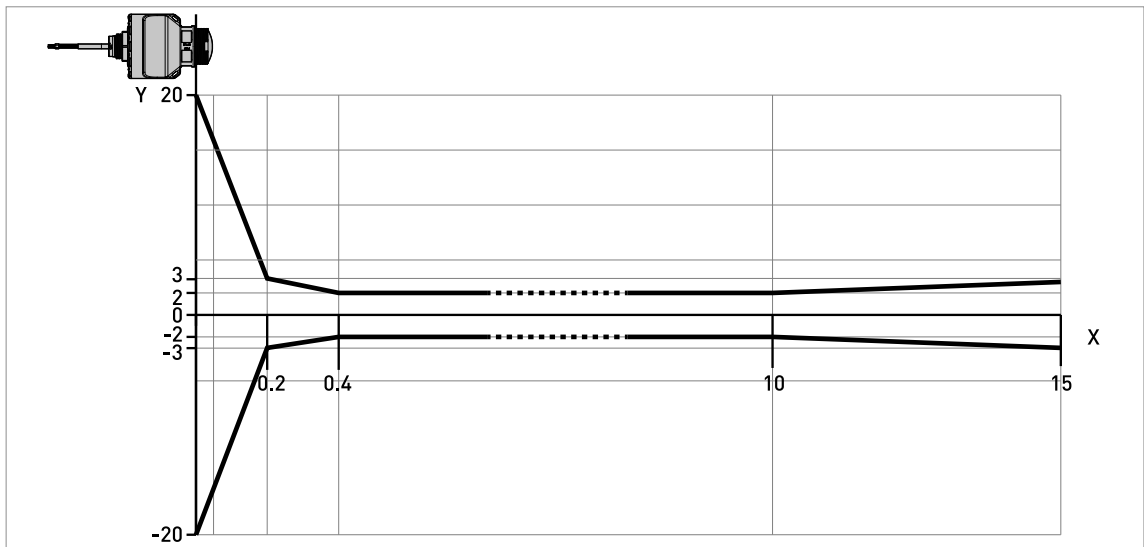

Figure 2-5: Graph of accuracy in mm against measuring distance in m

X: Measuring distance from the bearing surface of the threaded connection [m]

Y: Accuracy [+yy mm / -yy mm]

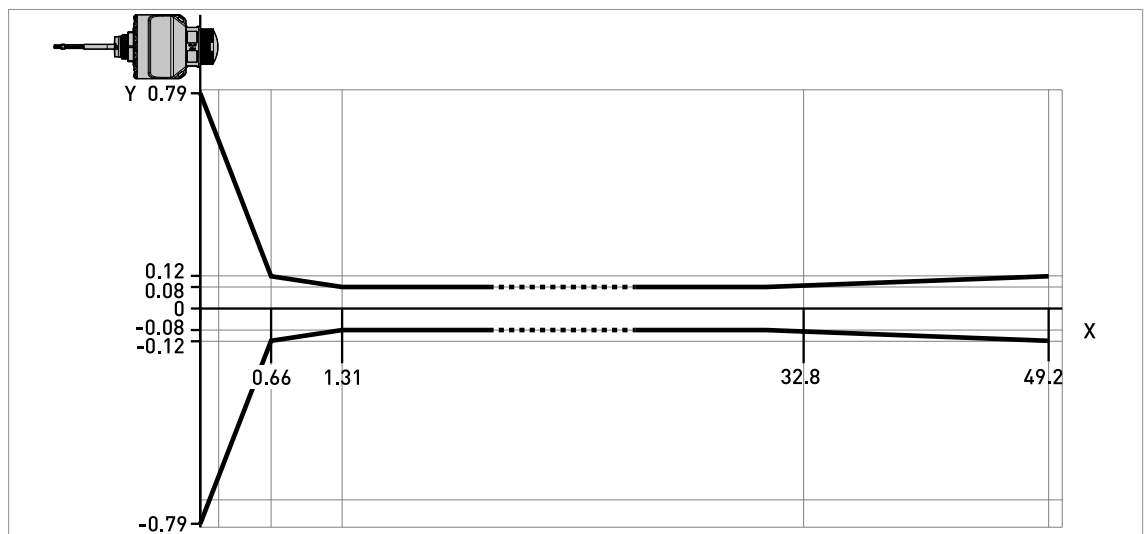

Figure 2-6: Graph of accuracy in inches against measuring distance in ft

X: Measuring distance from the bearing surface of the threaded connection [ft]

Y: Accuracy [+yy inches / -yy inches]

2.4 Dimensions and weights

2.4.1 OPTIWAVE 1520 or 1540

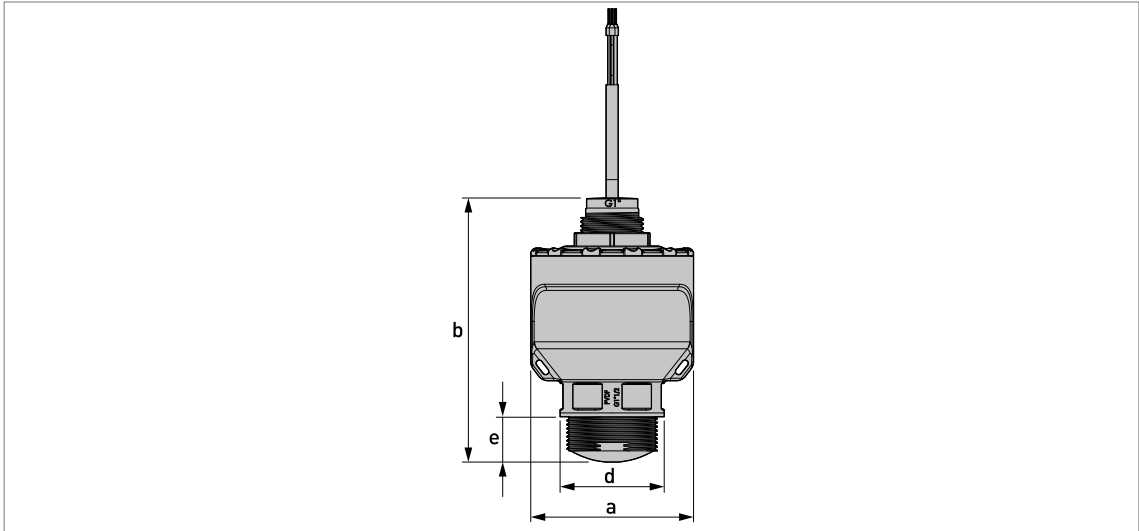

Figure 2-7: OPTIWAVE 1520 or 1540 with DN40 / 1½" Lens antenna

- A weather protection cover is available as an accessory with all devices.

Dimensions							
a		b		d		e	
[mm]	[inch]	[mm]	[inch]	[mm]	[inch]	[mm]	[inch]
86	3.39	139	5.47	55	2.17	28	1.10

Table 2-2: Dimensions in mm and inches

2.4.2 Cable clamp (accessory)

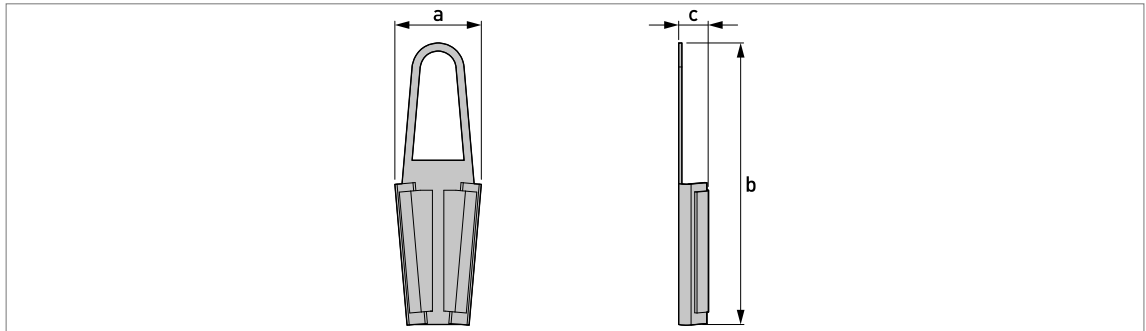

Figure 2-8: Cable clamp (accessory)

Dimensions					
a		b		c	
[mm]	[inch]	[mm]	[inch]	[mm]	[inch]
54	2.13	174	6.85	18.4	0.72

Table 2-3: Dimensions in mm and inches

2.4.3 Long bracket (accessory)

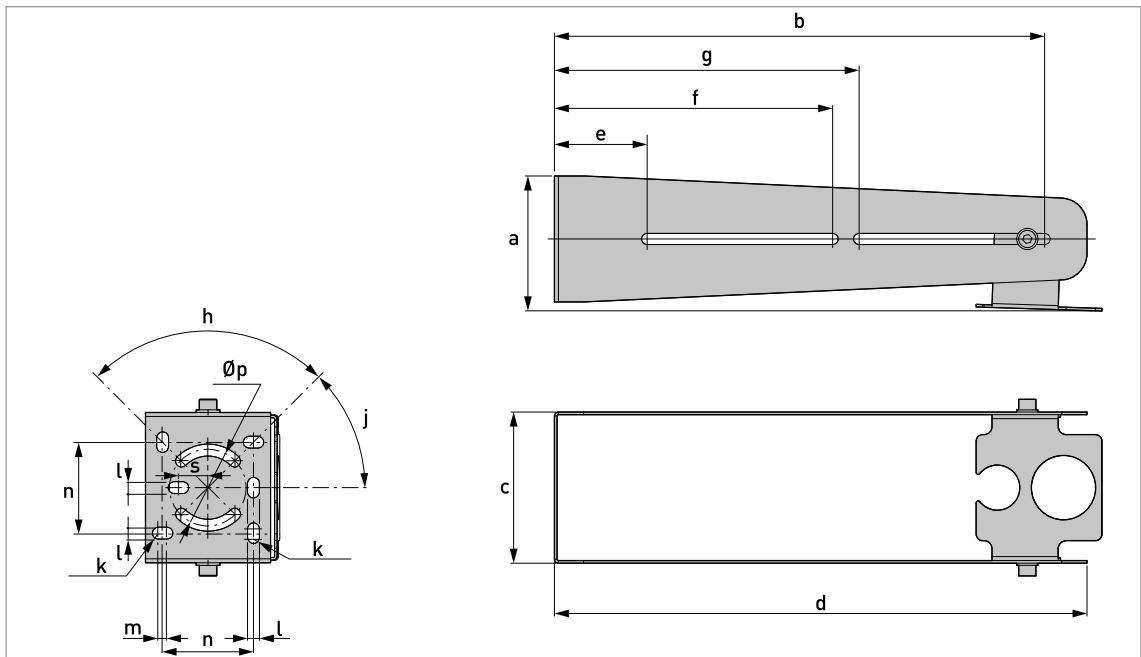

Figure 2-9: Long bracket (accessory)

Dimensions [mm]														
a	b	c	d	e	f	g	h	j	k	l	m	n	$\varnothing p$	s
102	370	114	402	70	210	230	90°	45°	R4.5	9	6.5	69	57	22.5

Table 2-4: Dimensions in mm

Dimensions [inch]														
a	b	c	d	e	f	g	h	j	k	l	m	n	$\varnothing p$	s
4.02	14.57	4.49	15.83	2.76	8.27	9.06	90°	45°	R0.18	0.35	0.26	2.72	2.24	0.89

Table 2-5: Dimensions in inches

2.4.4 Short bracket (accessory)

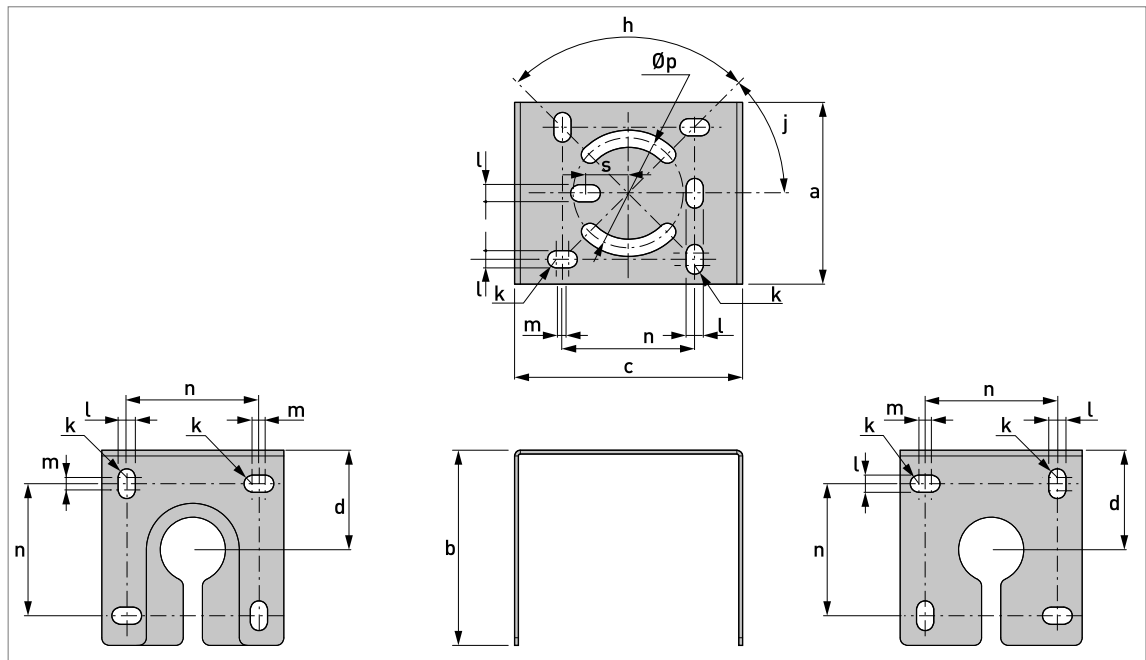

Figure 2-10: Short bracket (accessory)

Dimensions [mm]											
a	b	c	d	h	j	k	l	m	n	Øp	s
95	102	119	52	90°	45°	R4.5	9	6.5	69	57	22.5

Table 2-6: Dimensions in mm

Dimensions [inch]											
a	b	c	d	h	j	k	l	m	n	Øp	s
3.74	4.02	4.69	2.05	90°	45°	R0.18	0.35	0.26	2.72	2.24	0.89

Table 2-7: Dimensions in inches

2.4.5 Purging system (accessory)

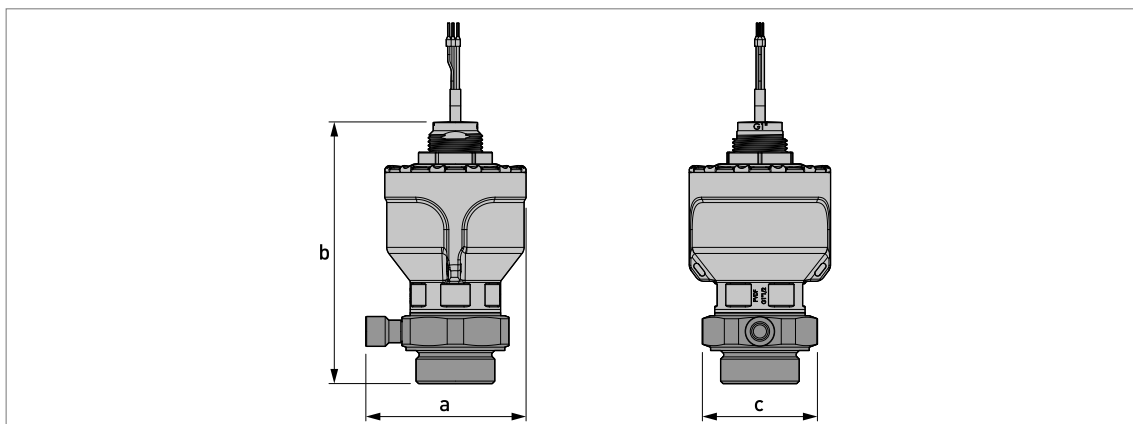

Figure 2-11: Purging system (accessory)

Process connection	Dimensions					
	a		b		c	
	[mm]	[inch]	[mm]	[inch]	[mm]	[inch]
G 1 / 1 NPT	97.5	3.84	158	6.22	70	2.76

Table 2-8: Dimensions in mm and inches

2.4.6 Orientation system (accessory)

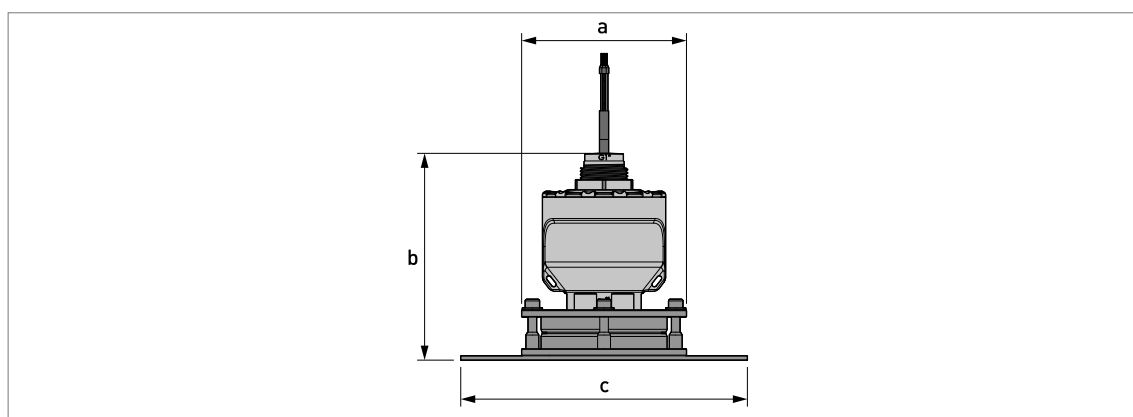

Figure 2-12: Orientation system (accessory)

Dimensions					
Øa		b		Øc	
[mm]	[inch]	[mm]	[inch]	[mm]	[inch]
115	4.53	144	5.67	①	①

Table 2-9: Dimensions in mm and inches

- ① DN80 PN01 = 200 mm / 7.87". DN100 PN01 = 235 mm / 9.25". DN125 PN01 = 270 mm / 10.63". DN150 PN01 = 300 mm / 11.81".
 DN200 PN01 = 345 mm / 13.58". NPS 3 Class 150 = 200 mm / 7.87". NPS 4 Class 150 = 235 mm / 9.25". NPS 5 Class 150 = 270 mm / 10.63". NPS 6 Class 150 = 300 mm / 11.81". NPS 8 Class 150 = 345 mm / 13.58".

2.4.7 Weather protection cover (accessory)

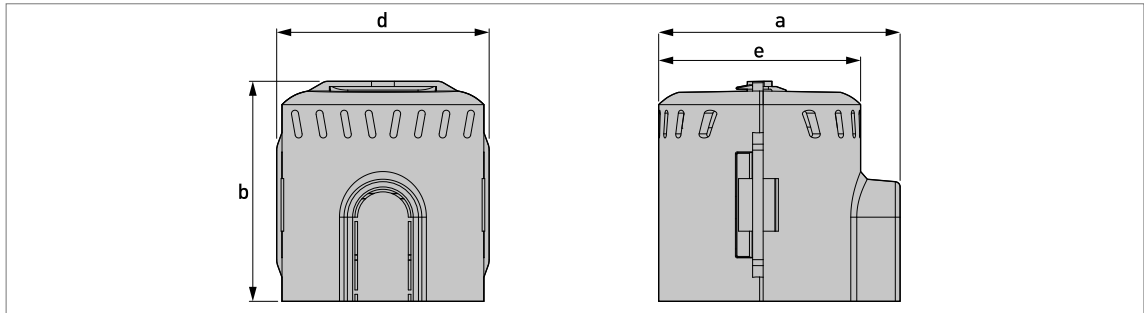

Figure 2-13: Weather protection cover (accessory)

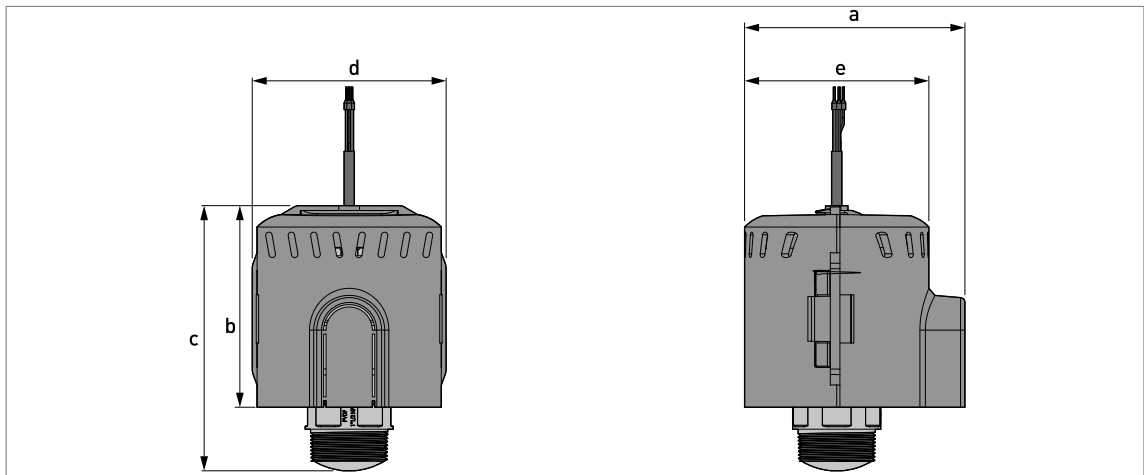

Figure 2-14: Weather protection cover attached to the device

Device	Dimensions										Weights	
	a		b		c		d		e			
	[mm]	[inch]	[mm]	[inch]	[mm]	[inch]	[mm]	[inch]	[mm]	[inch]	[kg]	[lb]
Weather protection cover	137.5	5.41	125.5	4.94	—	—	121	4.76	115	4.53	0.22	0.49
OPTIWAVE 1520 / 1540 with weather protection cover	137.5	5.41	125.5	4.94	165.1	6.50	121	4.76	115	4.53	0.66	1.45

Table 2-10: Dimensions in mm and inches / weights in kg and lb

2.4.8 Weights

Type of housing	Weights	
	[kg]	[lb]
Device with IP68-certified housing and DN40 antenna	0.44	0.97
Accessory		
Cable clamp	0.155	0.34
Weather protection cover	0.22	0.49
Long bracket	1.30	2.87
Short bracket	0.363	0.80
Nut (PVC-U) for the bracket accessories	0.043	0.09

Table 2-11: Weights in kg and lb

3.1 Intended use

This radar level transmitter measures distance, level, volume and reflectivity of liquids, pastes, slurries and granulates.

It can be installed on tanks, reactors, open channels, open water, silos, hoppers and bunkers.

Responsibility for the use of the measuring devices with regard to suitability, intended use and corrosion resistance of the used materials against the measured fluid lies solely with the operator.

The manufacturer is not liable for any damage resulting from improper use or use for other than the intended purpose.

3.2 Pre-installation requirements

Obey the precautions that follow to make sure that the device is correctly installed.

- Make sure that there is sufficient space on all sides.
- Heat sources (sunlight, adjacent system components etc.) can increase the internal temperature of the device and cause damage. Make sure that the sensor temperature shown on the user interface is not more than +80°C / +176°F. The maximum permitted surface temperature is +80°C / +176°F. If it is necessary to decrease the temperature, install the weather protection cover.
- Protect the device from abrasive materials (e.g. sand, salt etc.) and corrosion. If necessary, install the weather protection cover.
- Make sure that objects (for example, loose rubble in quarries) do not hit the device.
- The devices are tested for their resistance to vibrations. For more data, refer to *Technical data* on page 7.
- The device housing and all wetted parts are made of PVDF. Make sure that the ambient conditions and the measured product are compatible with PVDF.

3.3 Installation

We recommend that you prepare the installation when the tank is empty.

3.3.1 Pressure and temperature ranges

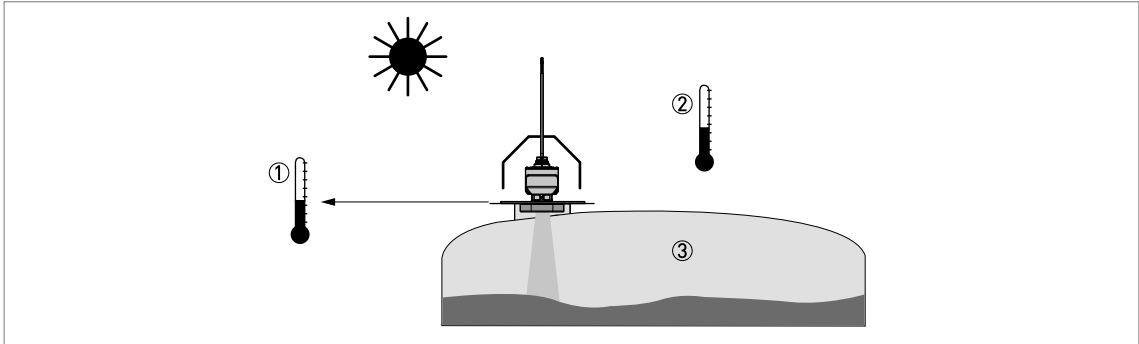

Figure 3-1: Pressure and temperature ranges

- ① Temperature at the process connection
Non-Ex devices: $-25...+80^{\circ}\text{C}$ / $-13...+176^{\circ}\text{F}$
Devices with Hazardous Location approvals: see supplementary instructions
- ② Ambient temperature
Non-Ex devices: $-25...+80^{\circ}\text{C}$ / $-13...+176^{\circ}\text{F}$
Devices with Hazardous Location approvals: see supplementary instructions
- ③ Process pressure
 $-1...5$ bar / $-14.5...72.5$ psi

3.3.2 Types of installation

Accessories are available for installation of the device on a nozzle, wall, tube or other support.

Use brackets that are supplied by the manufacturer to prevent measurement errors.

Socket

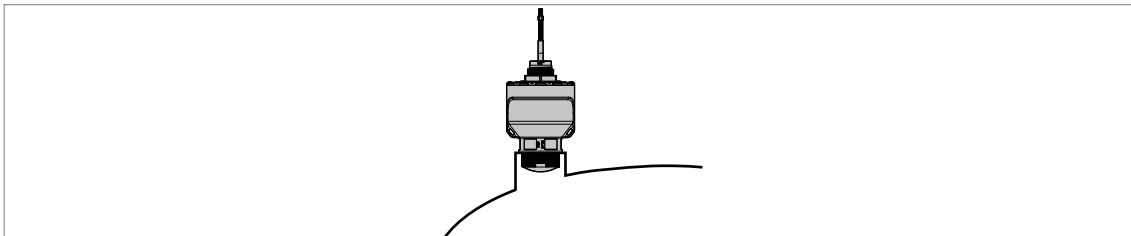

Figure 3-2: Threaded socket (NPT or G)

Low-pressure flange installed on a nozzle

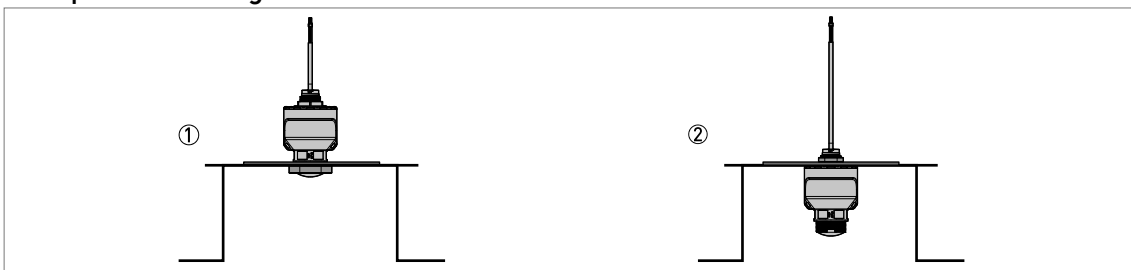

Figure 3-3: Installation of a device with a low-pressure flange (accessory)

- ① Device installed on the top of a low-pressure flange
- ② Device installed on the bottom of a low-pressure flange

Select a low-pressure flange that is compatible with the threaded connection on the device and is the correct size for the flange on the nozzle.

Orientation system installed on a nozzle

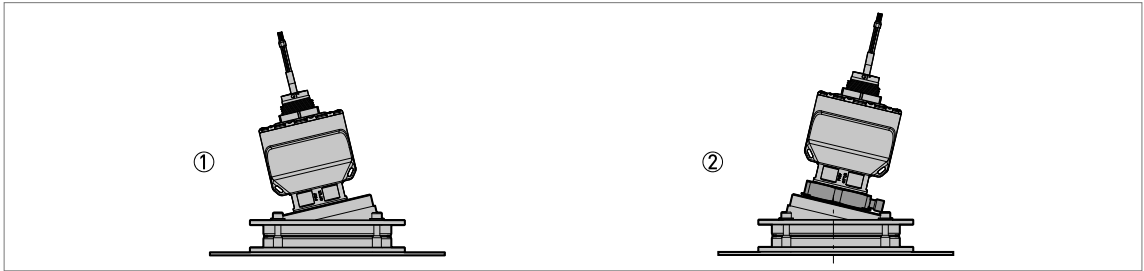

Figure 3-4: Installation of a device with an orientation system (max. tilt 30°)

- ① Device with the orientation system for level measurement of piles or silo contents
- ② Device with the orientation system and the purging system option

The orientation system has a low-pressure flange. Select an orientation system accessory that is compatible with the threaded connection on the device and is the correct size for the flange on the nozzle. For dimensional data, refer to *Dimensions and weights* on page 16. For part references, refer to the handbook (appendix).

Installation on a wall, ceiling or tube

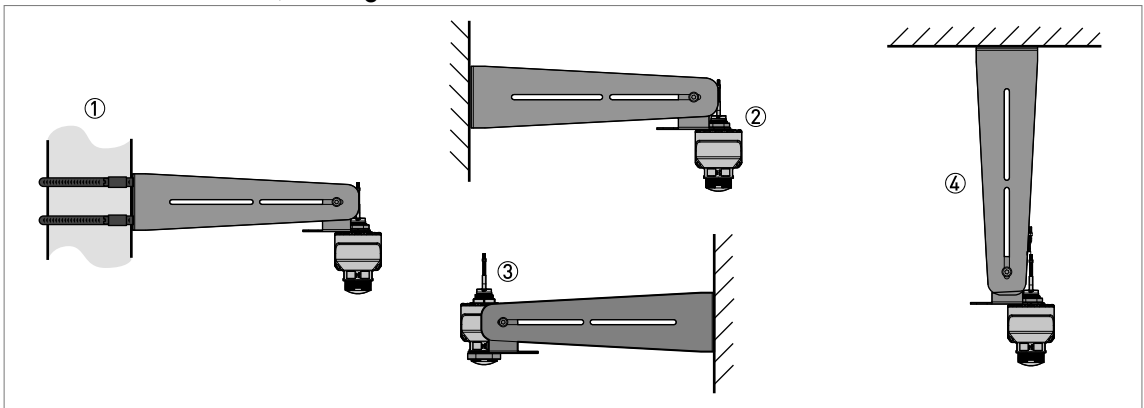

Figure 3-5: Installation on a wall, ceiling or tube with a long bracket

- ① Long bracket attached to a tube with a U-bolt or a metal collar (not supplied)
- ② Wall installation: top of the device attached to the long bracket
- ③ Wall installation: bottom of the device attached to the long bracket
- ④ Long bracket attached to the ceiling

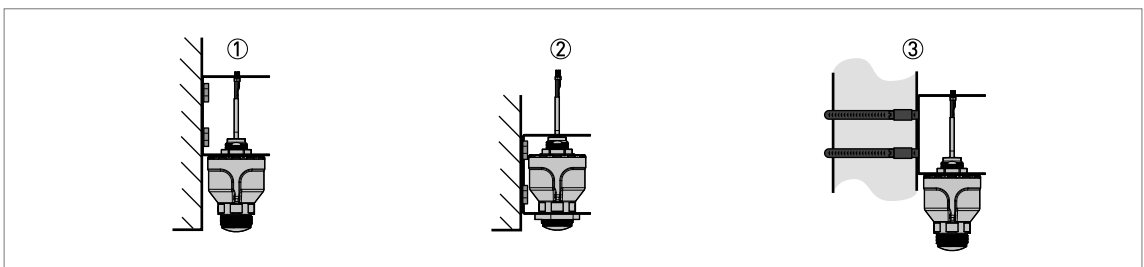

Figure 3-6: Installation on a wall or tube with a short bracket

- ① Wall installation: top of the device attached to the short bracket
- ② Wall installation: bottom of the device attached to the short bracket
- ③ Short bracket attached to a tube with a U-bolt or a metal collar (not supplied)

For part references, refer to the handbook (appendix).

Installation on a hook

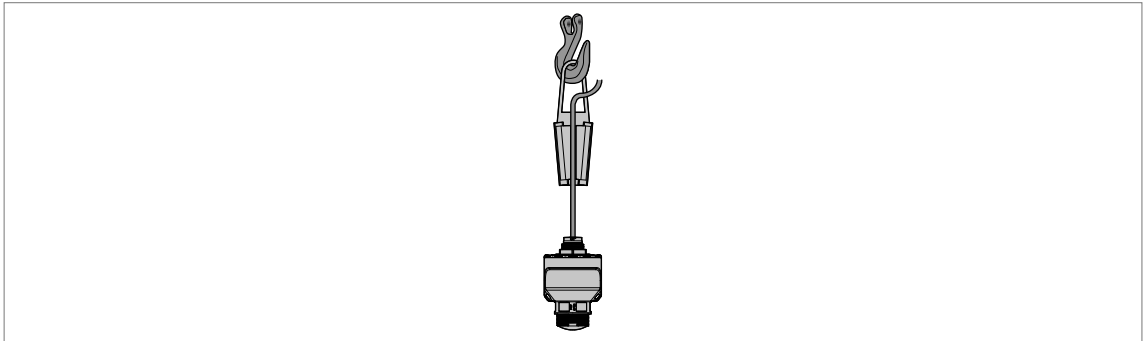

Figure 3-7: Installation on a hook with an electrical cable clamp (IP68 housing option only)

For part references, refer to the handbook (appendix).

Use good engineering practice to keep the mechanical loads on the electrical cable and device to a minimum.

3.3.3 Positioning the device

If there is a nozzle on the tank before installation, we recommend that the nozzle is a minimum of 200 mm / 7.9" from the tank wall.

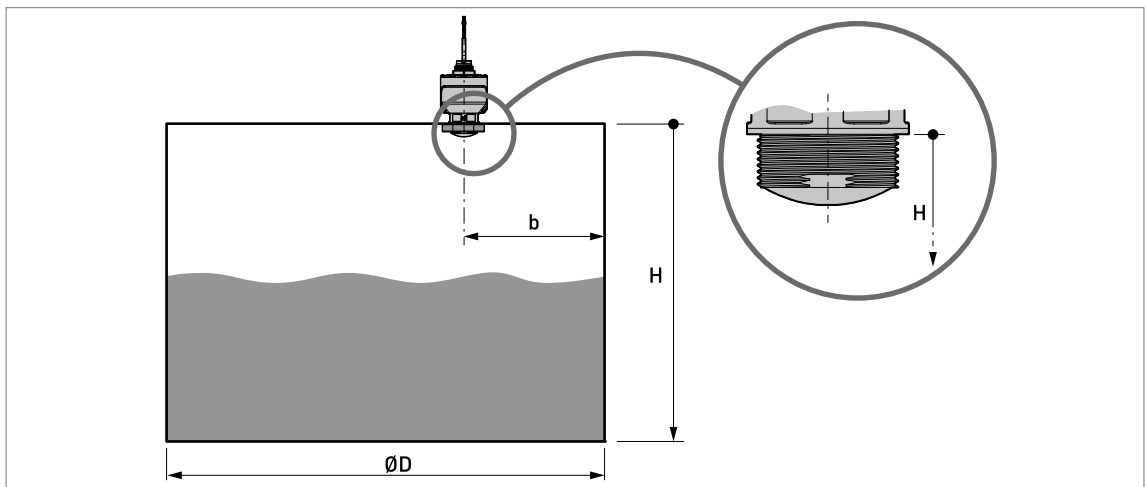

Figure 3-8: Position of the nozzle or socket on a tank

H = tank height

ØD = tank diameter

b = distance of the device from the tank wall = 1/10 x tank height

3.3.4 Equipment and obstacles

The tank wall must be flat and there must not be obstacles adjacent to the nozzle or on the tank wall.

Objects in the tank or pit can cause interference signals. Do not install the device above objects in the tank (ladder, supports etc.) or pit.

If it is not possible to install the device on another part of the tank, do an empty spectrum scan to detect sources of radar signal interference and put these parasitic signals through a filter. For more data, refer to the handbook.

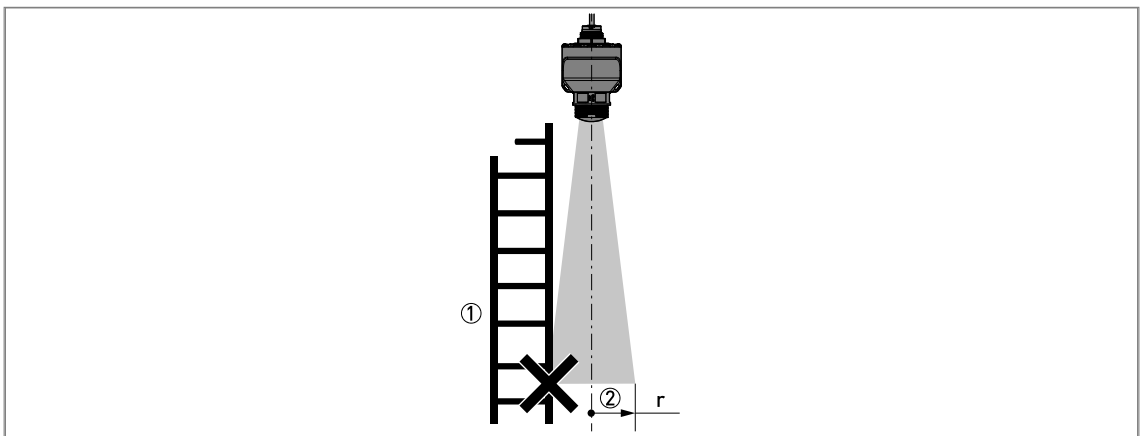

Figure 3-9: Equipment and obstacles: how to prevent measurement of interference signals

- ① Obstacle. Move the device away from the obstacle. If it is not possible to move the device, do an empty spectrum scan (refer to the handbook).
- ② Beam radius, r , of the antenna: refer to the table below

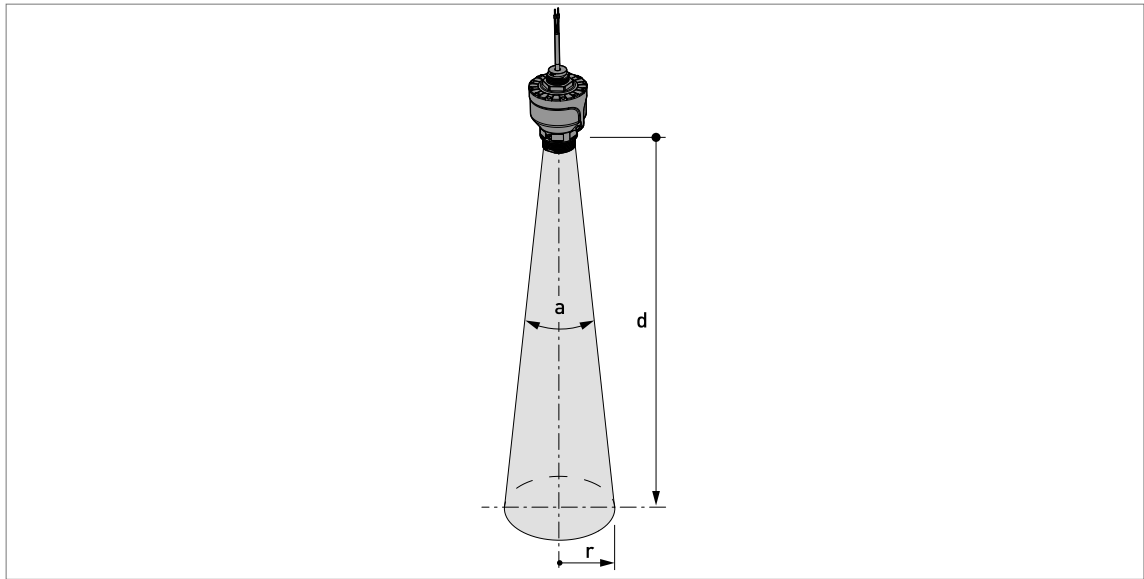

Figure 3-10: Beam angle

Antenna type	Beam angle, a	Distance below the antenna, d	Beam radius, r	Distance below the antenna, d	Beam radius, r
		[m]	[mm]	[ft]	[inch]
Lens, DN40 (1½")	8°	1	70	1	0.8
		2	140	2	1.6
		10	700	10	8

Table 3-1: Beam radius in mm and inches

The beam radius given in the table is the minimum free space from the centre of the beam for the device to operate correctly in a tank with obstacles. We recommend a safety factor of 3 (free space = beam radius x 3) to keep parasite signals to a minimum.

3.3.5 Product inlets on tanks and silos

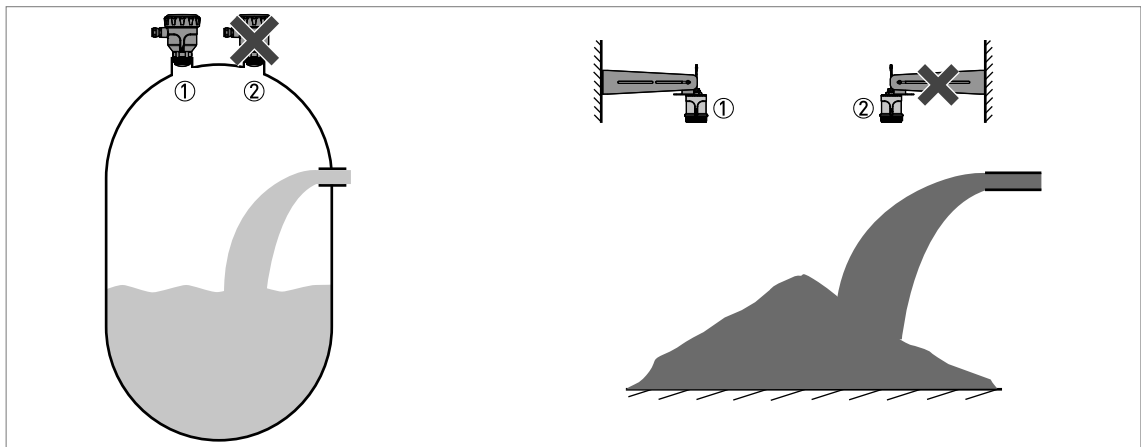

Figure 3-11: Do not put the device near to a loading inlet

- ① The device is in the correct position.
- ② The device is too near to the product inlet.

If the inlet is too near to the device and it is not possible to move it, add an extension to the inlet pipe to prevent interference signals.

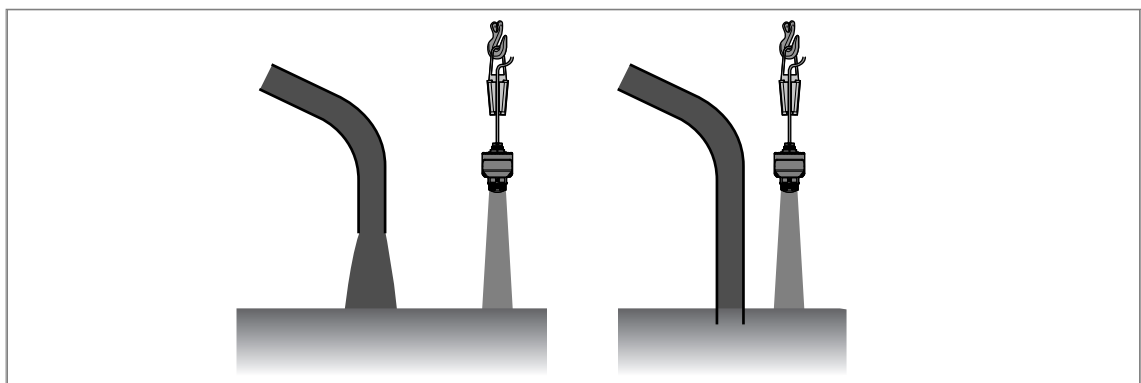

Figure 3-12: Add an extension to the inlet pipe to prevent interference signals

3.3.6 Tanks, hoppers and silos with dish-shaped or conical bottoms

If the device measures vertically, then dish-shaped or conical bottoms can prevent the device from measuring to the bottom of the tank.

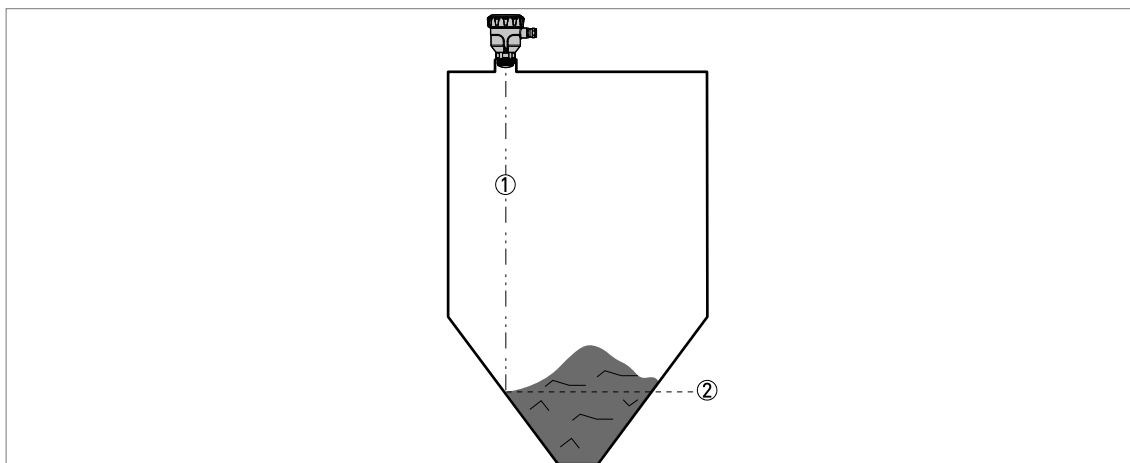

Figure 3-13: Tanks with dish-shaped or conical bottoms

- ① Axis of the radar beam
- ② Minimum level reading

You can measure to the bottom of a tank or silo if you follow these instructions:

- Select an application in the Quick Setup menu of the DTM software or mobile app that switches on the tank bottom management function (refer to the list that follows).
- Use the orientation system accessory that permits you to tilt the device a maximum of 30° from the vertical axis.

Applicable applications are:

- **Solids:** Narrow Silo, Bunker, Large Silo, and Stockpile

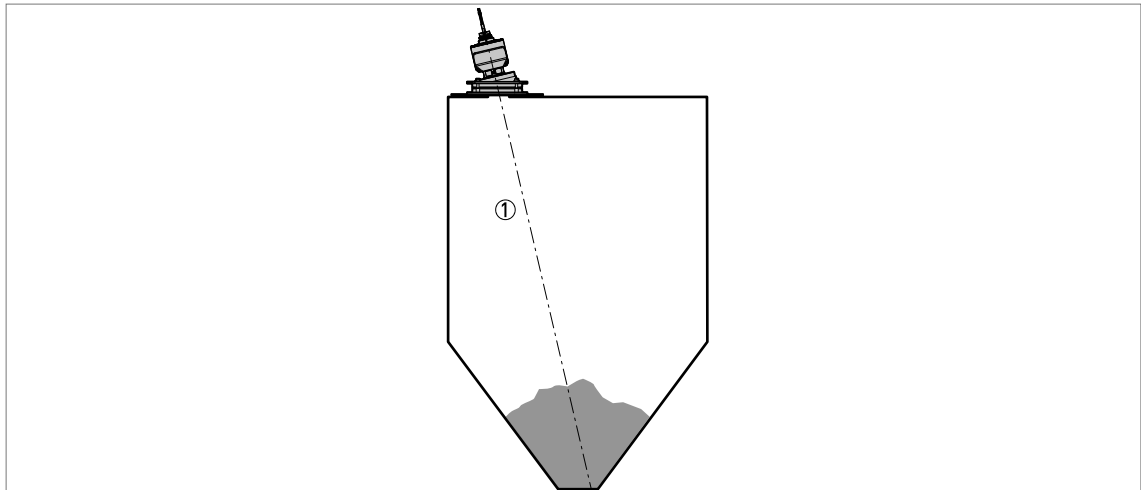

Figure 3-14: Tanks with dish-shaped or conical bottoms

- ① Axis of the radar beam

3.3.7 Containers made of non-conductive materials

We recommend that you do not hang and use this device above a plastic tank that has a layer of dust, condensation or a standing body of liquid on it. Dust and liquid can have an effect on the device performance.

If the device cannot go in the tank and the tank is made of a non-conductive material (plastic etc.), you can attach a support to the top of the tank without a hole in the tank roof. We recommend that you put the antenna as near as possible to the top of the tank.

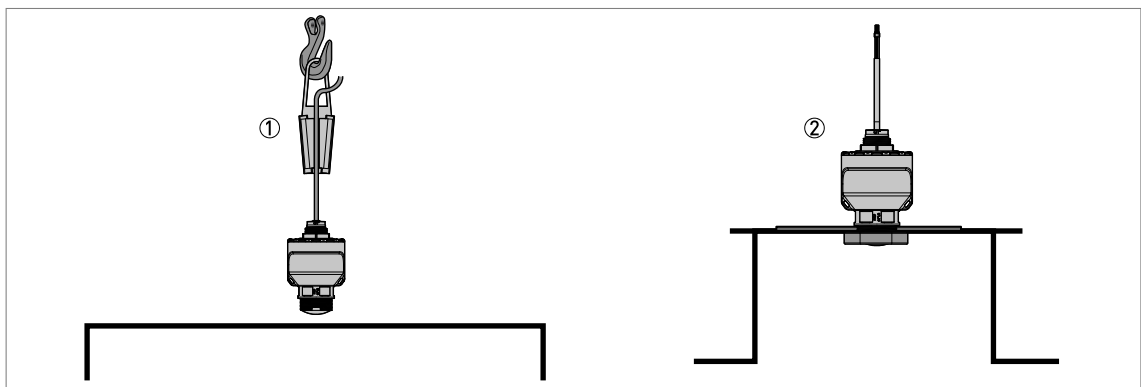

Figure 3-15: Containers made of a non-conductive material

- ① Device hung above a plastic tank
 ② Device attached to a plastic tank with a low-pressure flange

4.1 General notes

This chapter includes electrical connection data about devices with the 4...20 mA output and HART® communication options. These are 2-wire, loop-powered devices.

4.2 Electrical connection for current output

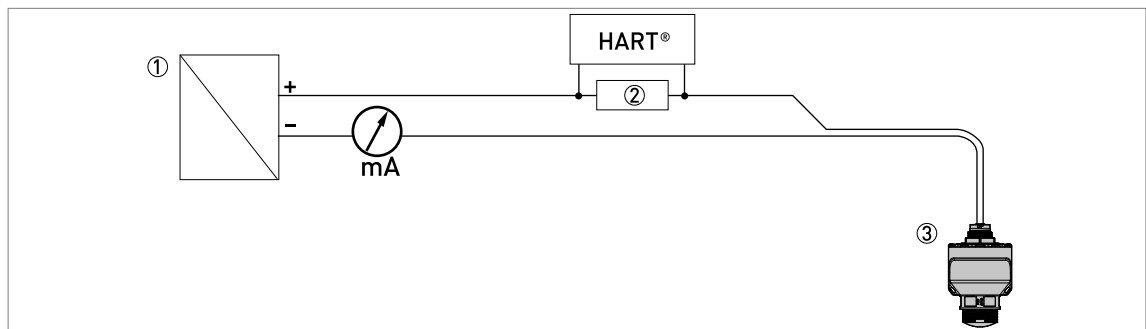

Figure 4-1: Electrical connections for non-Ex devices

- ① Power supply
- ② Resistor for HART® communication (typically 250 ohms)
- ③ Device

- *Make sure that there is an external switch or circuit breaker adjacent to the device. It must disconnect the positive and negative lines in the DC circuit.*
- *You must have access to the external switch or circuit breaker, and it must be identified as the electrical safety equipment for this device.*
- *The output of the power supply must be LPS-rated (limited power source – IEC 62398-1 Annex Q) for a SELV (separated extra-low voltage) system.*
- *Use a Class 2 (UL 1310) power supply for electrical installations in the USA and Canada.*

The electrical cable is supplied with the device and cannot be replaced.

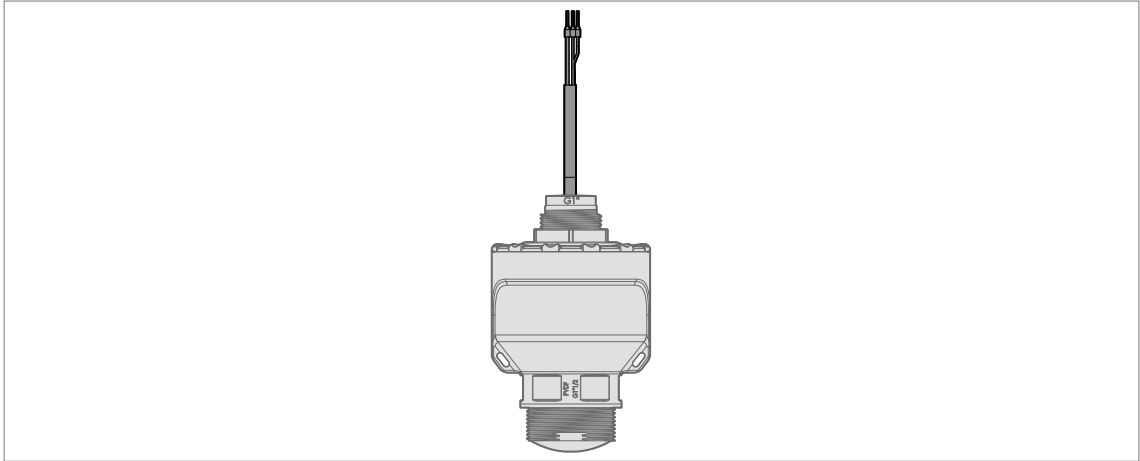

Figure 4-2: IP68 option

Install protection for the electrical cable, if the device is in a location where there is a risk of damage from wildlife (rats etc.).

4.3 Networks

The device uses the HART® communication protocol. This protocol agrees with the HART® Communication Foundation standard. The device can be connected point-to-point. It can also have a polling address of 1 to 63 in a multi-drop network.

KROHNE – Products, Solutions and Services

- Process instrumentation for flow, level, temperature, pressure measurement and process analytics
- Flow metering, monitoring, wireless and remote metering solutions
- Engineering, commissioning, calibration, maintenance and training services

ETA Process Instrumentation

www.etapii.com

sales@etapii.com

tel: 978.532.1330

New England

Martech Controls

www.martechcontrols.com

sales@martechcontrols.com

tel: 315.876.9120

Upstate New York

KROHNE