

PRODUCT BROCHURE

LPDT2™

Ultra-Compact, Loop-Powered
Aluminum Oxide Sensor Transmitter
-100°C to + 20°C Dew Point



No display version



Standard version with display

Reliable and Fast

Cost-Effective

Low Maintenance

- Hydrogen Service
- Monitoring and control of air dryers
- Glove boxes
- Welding gases
- Clean room environments



Our LPDT2™ is an **ultra-compact, loop-powered dew point transmitter** available with or without a display. The LPDT2 offers users even more control and options for customized dew point monitoring. Features include:

- **LPDT2 with display** features a custom LCD display with pushbutton control enabling users to view, select, and set options at the transmitter.
 - **LPDT2 No Display** Provides reliability to users without the additional expense of on-board transmitter control.
- Loop Powered, with 4-20mA analog output
 - Digital outputs via MODBUS 485
 - User Selectable Settings for units of measure
 - 3 Field Calibration options: single point, span check and Offset
 - NEMA 4 IP66 Housing
 - Display unit can be rotated to read upright
 - Optional CI 1 Div 2 / Zone 2 area ratings
 - Low cost of ownership and maintenance

Certifications

USA and Canada	Class I, Division 2, Groups A, B, C, D, T5, Tamb: $-10^{\circ}\text{C} \leq \text{Ta} \leq +70^{\circ}\text{C}$ Class I, Zone 2, AEx ic IIC T5 Gc, Tamb: $-10^{\circ}\text{C} \leq \text{Ta} \leq +70^{\circ}\text{C}$
ATEX	Zone 2 (II 3 G Ex ic IIC T5 Gc, Tamb: $-10^{\circ}\text{C} \leq \text{Ta} \leq +70^{\circ}\text{C}$)
UKEX	Zone 2 (II 3 G Ex ic IIC T5 Gc, Tamb: $-10^{\circ}\text{C} \leq \text{Ta} \leq +70^{\circ}\text{C}$)
IECEX	Zone 2 (Ex ic IIC T5 Gc, Tamb: $-10^{\circ}\text{C} \leq \text{Ta} \leq +70^{\circ}\text{C}$)

Applications

- Glove boxes
- Clean room environments
- Natural gas transmission
- Hydrocarbon processing
- Air dryers and compressors
- Hydrogen Service
- Specialty air gases
- Cryogenic
- Air generators

Drawing

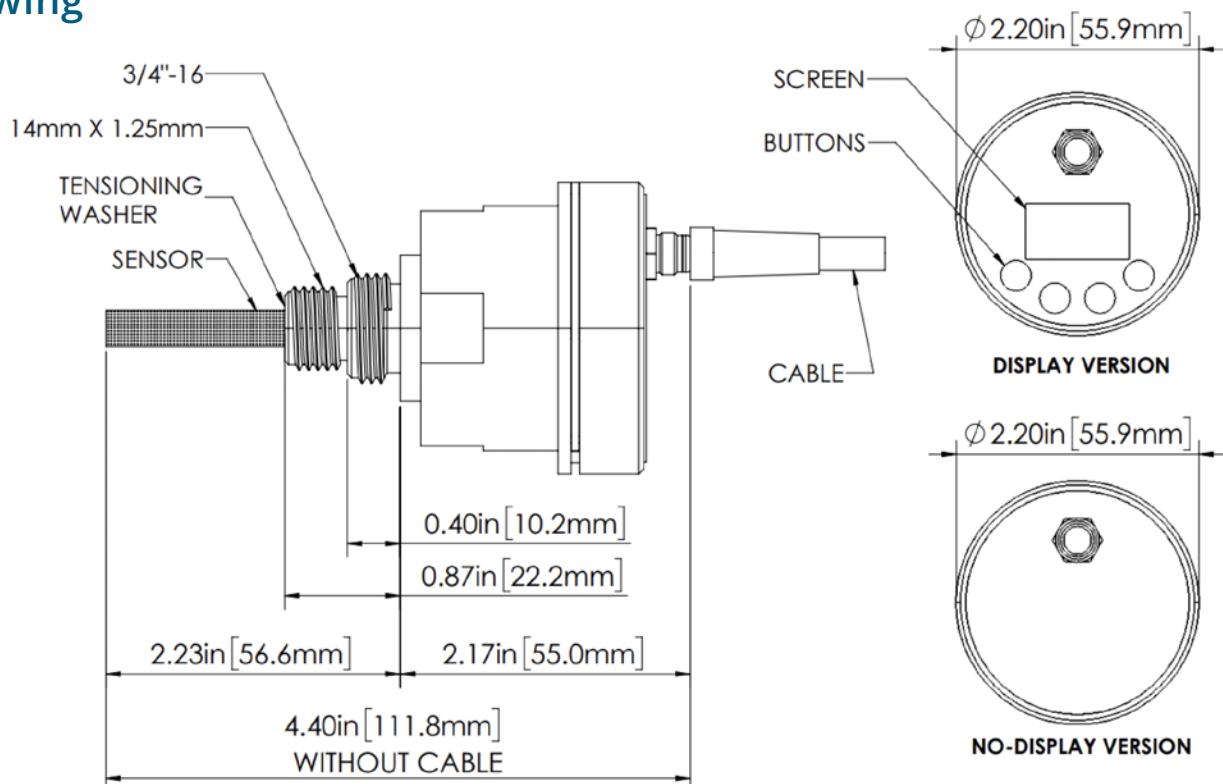

Selectable User Settings may be controlled via an Optional Controller/Display mounted in the transmitter. See chart below for available settings and control levels for both transmitter options.

Settings	LPDT	LPDT2 No Display (Modbus Controlled)	LPDT2 Display Controlled
Select Units of Measure for output reading (°C, °F, ppm, lbs, g/m3)	Yes	No	Yes
Display up to two Alternating Units of Measure	Yes	No	Yes
Lock and Unlock settings	Yes	No	Yes
Single Point Calibration, with a known gas value	No	No	Yes NEW
Span Check Calibration	Yes	No	Yes
Offset Adjustment	No	YES NEW	YES NEW
Show Sensor Data (transmitter and sensor Serial number)	No	Yes	Yes
Test the 4-20mA out put	Yes	Yes	Yes
Customize the Scale on 4-20mA output	Yes	Yes	Yes
Rotating Front Panel	Yes	Yes	Yes

TECHNICAL SPECIFICATIONS

Dew Point Sensor Element	
Type:	Hyper-Thin-Film high capacitance Al ₂ O ₃ dew point range, XTR-100 -100°C to +20°C (-148°F to +68°F), XTR-65 -65°C to +20°C (-85°F to +68°F)
Sensor Range: Model: XTR-65 Model: XTR-100	-65°C to +20°C (-85°F to +68°F) -100°C to +20°C (-148°F to +68°F)
Accuracy:	±3°C (± 5.5°F) for -100°C to +20°C dew point
Repeatability:	±0.5°C (±0.9°F)
Operating Temperature range:	-10°C to +70°C (+14°F to +158°F) Class T5
Sample Flow Range (linear vel. @ 1 atm.):	1-4LPM
Storage Temperature:	-40°C to +80°C (-40°F to +176°F)
Calibration Method:	Factory; NIST/NPL traceable, multipoint calibration; Field; single point, span check and Offset (display unit)
Electronics	
Input resolution:	0.1°C (dp)
Indicators:	3.5 digit LCD with custom legends on display unit
Engineering units:	°C, °F, ppmv, LBS H ₂ O/mm scf, gm H ₂ O/m ³ with display only
Controls:	4 push buttons, all settings stored in EPROM
Output:	Analog 4-20mA; modbus 485 interface
Isolation:	Sensor and case are isolated from the current loop and shunted with 33V transorbs
Mechanical	
Enclosure:	Stainless steel NEMA 4 IP66 enclosure
Pressure operating range:	340 bar (5,000 PSI)
Electrical connections:	Device: Molex 1200905081, 5 pin male connector Mate: Molex 1200860192, 5 pin female connector
Cable:	5 conductor cables, 12ft cable provided, can configure for 2 wire system
Power Requirements:	10 to 33 VDC, the instrument draws 4-20mA depending on measurement dew point
Warranty:	One year

GAIN REAL-TIME INSIGHT INTO YOUR PROCESS

Process Insights delivers premium analytical sensors, analyzers, instrumentation, software and solutions that are mission-critical to keep your operations, personnel, and the environment safe. Our commitment to customer satisfaction is evident through our diverse range of products, programs, and services, designed to accommodate various budgets and application needs.

ETA Process Instrumentation

www.etapii.com
sales@etapii.com
tel: 978.532.1330

New England

Martech Controls

www.martechcontrols.com
sales@martechcontrols.com
tel: 315.876.9120

Upstate New York

For a complete range of products, applications, systems, and service options, please contact us.

