

PRODUCT DATASHEET

Series XDT™

Dewpoint Transmitter
-100°C to + 20°C Dewpoint



Applications

- Monitoring and control of air dryers
- Plastic dryers
- Welding gases
- Laser gases
- Petrochemical feedstock gases
- Natural gas processing, transportation and distribution
- Clean rooms
- Transformer and switch gear insulation gases
- Glove boxes
- Cryogenic gases
- Heat treating furnaces
- Industrial specialty gases

General

The digital dewpoint transmitters are designed as compact, simple and reliable instruments, which will continually monitor air dryer performance, compressed air quality and dry gas moisture, from ambient dewpoint levels to as low as -100°C (-148°C).

Applications

Dewpoint transmitters are used wherever the dewpoint in a gas is critical. Applications include: monitoring and control of air dryers, plastic dryers, welding and laser gases, petrochemical feedstock gases, natural gas, clean rooms, glove boxes, transformer and switch gear insulation gases, cryogenic gases, heat treating furnaces, industrial specialty gases and many more.

Electronics

The transmitter electronics take full advantage of state of the art microprocessor technology and offer many advanced intelligent features. With optional dual alarms, analog and digital outputs, the dewpoint transmitters can be used as indicators, alarm units or controllers.

Programmable Alarm Relays Option

The two optional alarm relays can be independently programmed to switch at any dewpoint with variable hysteresis, which makes the transmitter ideally suited as an energy saving controller for desiccant dryers in "dewpoint demand" mode or safety cutoff in process control, high power laser, etc. The status of the relays is shown on the display with flashing HI or LO indicators while displaying the dewpoint.

Analog and Digital Outputs Options

Analog and digital outputs are isolated from the sensor. The analog current or voltage output can be programmed to span the full or a portion of the range and is linear to the selected engineering units. The RS-232 interfaces into the serial port of any PC or Mac, for a simple operation with any standard communications program.

User-friendly interface

The instrument is operated through a menu driven user interface consisting of a custom LCD display with backlight, and four push buttons.

Engineering Units

The user can select from the following engineering units. Dewpoint in $^{\circ}\text{C}$ or $^{\circ}\text{F}$, ppmv, $\text{g H}_2\text{O}/\text{m}^3$, lbs $\text{H}_2\text{O}/$ million scf.

Pressure Correct Function

Results are displayed at sensor pressure or by pushing the Pressure Correct key at a user selectable alternate pressure, such as the line pressure.

SpanCheck in the Field

This field calibration procedure is fully automated and the user is prompted through a simple one minute procedure, which requires no additional equipment.

Error Indication

The instrument has indication for sensor open, short or electronic system failure, which can activate any of the alarm relays.

NIST / NPL Traceability Option

Certificates for NIST and NPL traceability are available upon request. Instruments can be recertified periodically at Xentaur's laboratories.

Same Transmitter – Multiple Configurations



Model XDT-OEM™ is a stand alone board suitable for mounting in existing enclosures. Connections are made through a pluggable screw terminal block which allows cables to leave the board vertically or horizontally.

The electronic board can be broken into two parts and sandwiched to accommodate space constraints.



Model XDT-PM™ houses the transmitter in a panel mount industry standard DIN 43700 box, 7.5cm deep. Connections are made through a pluggable screw terminal block.

The panel mount model is available with the push buttons on the outside of the front panel (shown above) or with the push buttons hidden behind the front panel.



Model XDT-NEMA™ houses the transmitter in a NEMA 4 (IP65) enclosure. Ideally suited for industrial environments.

Can be ordered UL approved for use in Hazardous Locations Class I Division 2 Groups A, B, C & D; Class II Groups F & G. And optionally Providing Intrinsically Safe output for use in Hazardous Locations Class I Division 1 Groups A, B, C, & D; Class II Groups E, F & G.

Also Available: XDT in explosion proof enclosure, UL approved for use in Hazardous Locations Class I Division 1 Groups B, C & D; Class II Groups E, F & G. Provides Intrinsically Safe output for use in Hazardous Locations Class I Division 1 Groups A, B, C & D; Class II Groups E, F & G.

The HTF™ Aluminum Oxide sensor is the product of years of intensive research and has been thoroughly field proven. HTF technology offers significant performance advantages over all other aluminum oxide moisture sensors.

High Capacitance Response

Due to a hyper-thin film and a special pore geometry, sensors have a capacitance change over their full range, several orders of magnitude larger than that of conventional aluminum oxide sensors. Additionally, this change is quasi linear and its sensitivity to temperature is negligible. The advantages of a linear high capacitance response are: better sensitivity, better repeatability and faster response times. Also, the measurement system is less prone to noise and drift, and signal conditioning is kept to a minimum.

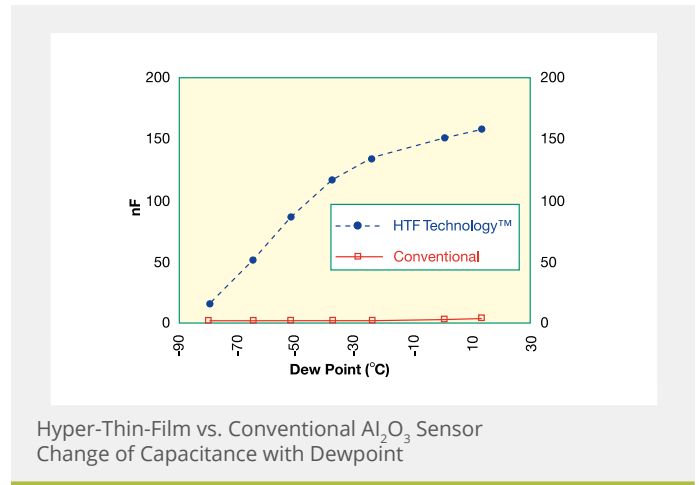

Interchangeable Sensors

HTF Al₂O₃ high capacitance sensors are manufactured with high uniformity. Consequently, sensors are freely interchangeable without factory calibration or changing of EPROMS, as is required with conventional aluminum oxide sensors.

SpanCheck without reference standards

HTF high capacitance sensors have a very low residual capacitance when dry, and saturate at a predesigned level of humidity above +20°C (+68°F). This allows a span check of the sensor by cupping the sensor in the palm of one's hand for one minute, and adjusting the instrument to its upper range limit.

The advantages of this span check system are obvious: sensors can be field calibrated anywhere, anytime without using expensive and cumbersome calibration standards. Sensors do not have to be returned to the factory for recalibration, which also eliminates the need for a second stand-by sensor.

Advanced Mechanical Sensor Design

The HTF sensors have been designed for the requirements of tough industrial environments. The sensor element is encapsulated in a 100 micron stainless steel sintered filter. The filter housing is screwed onto a stainless steel sensor fitting which is available for pressures of up to 340 bar (5000 psi) (FM tested). When sensor elements have to be replaced the sensor fitting can be saved. The sensor fitting has two mounting threads, which make it easy to use existing sample cells. The cable is connected through a BNC connector.



HTF Al₂O₃ Advantages:

- Up to 600x more sensitive than conventional sensors
- Sensors are freely interchangeable
- Field calibration with NIST traceable reference standards
- Faster response
- Better repeatability
- Longer sensor life
- Less drift
- Negligible temperature coefficient

TECHNICAL SPECIFICATIONS

HTF Sensors

Sensor element:	
Type	Hyper Thin Film high capacitance Al ₂ O ₃
Dewpoint range	XTR-100 -100°C to +20°C (-148°F to +68°F) XTR-65 -65°C to +20°C (-85°F to +68°F)
Capacitance	15 nF to 200 nF
Accuracy	± 2°C (±3.6°F) for -100° to 0° Dewpoint ± 3°C (±5.5°F) for - 0° to +20° Dewpoint
Repeatability	±0.5°C (±0.9°F)
Response time*	For a step change from -40°C to -60°C: 63% in 90 seconds 90% in 450 seconds
Temperature range	-30°C to +50°C (-22°F to 122°F)
Sample Flow range (linear velocity at 1 atm)	Static to 100 m/s
Storage temperature	-40°C to 50°C (-40°F to +120°F)
SpanCheck	Sensor saturates at dewpoint above +20°C (+68°F)
Fitting:	
Pressure operating range	Standard: 34 bar (500 psi) Optional: 340 bar (5000 psi)
Mechanical connections	14mm x 1.25mm threads, and 3/4"-16 threads (other threads available)
Electrical connections	Female BNC connector
Sensor cable	Coaxial cable (75Ω with maximum capacitance of 50 pF/m). Maximum cable length: 914 m (3000 ft)

* These response times are not directly comparable to competitors data because of differences in measurement methodology and data presentation. Please inquire for detailed comparisons between and other major sensor manufacturers. Our sensors are significantly faster.

TECHNICAL SPECIFICATIONS

XDT Series

Transmitter:	
Sensor type	High capacitance Al ₂ O ₃
Input Resolution	0.1°C dewpoint
Indicators	LCD with backlight, 3.5 digits and custom legends for units and mode, audio alert
Engineering units	Dewpoint in °F and °C, ppmv, g H ₂ O/m ³ , lbs H ₂ O/mm scf
Controls	4 push buttons, all settings stored in EEPROM
Output options	4-20mA, 0-24mA or voltage outputs, linear to selected engineering units, programmable span and range, 0.1°C dewpoint resolution. RS-232 , baud rate 9600, resolution 0.1°C dewpoint
Isolation	Sensor is isolated from the power supply, analog output and RS-232
Alarm relays option	Two programmable alarm relays with programmable variable hysteresis, rated at 10A @240V. Failure indication programmable to trigger alarm relays
Audible Alarm	>80dB @ 3ft. with silence feature
Visual Alarm	XDT display backlight will stay on as long as alarm condition exists
Test feature	Test button allows testing of both visual and audible indicators
Power requirements	100 - 240 VAC, 50 or 60 Hz, autoranging or by order 12VDC or 15-30VDC 0.5A
Connections	Pluggable screw terminal block
Enclosure	Polycarbonate, Nema 4/4x Dimensions W-12cm x H-16cm x D-9cm (W-4.7" x H-6.3" x D-3.5"); DIN 43700 - 8cm (3") deep
Temperature range of electronics	-10° to 50°C (14° to 122°F)
Optional Features	A) Medical Breathing Air Monitoring and Alarm Option, complies with the recommendations of NFPA 99, 1996 edition B) On-board battery backed real-time clock option, facilitating Scheduled Timer Activated Single Point Self Calibration/Verification procedure for sample systems equipped with an electrically actuated switchover valve.
Warranty	One year for full workmanship and defective parts

Class I, Division 1 Groups A, B, C, & D; Class II Groups E, F, & G;
Class I Division 2 Groups A, B, C, & D; Class II Groups F & G; EEx d[ia] IIB+H2

Dimensions of Element and Fitting (other threads are available)

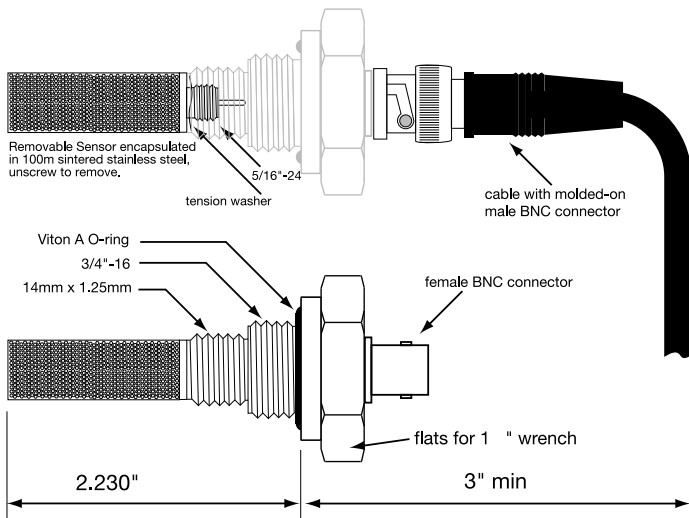

Sample cells and complete sampling systems available. For more information, refer to website.

Dimensions XDT-OEM

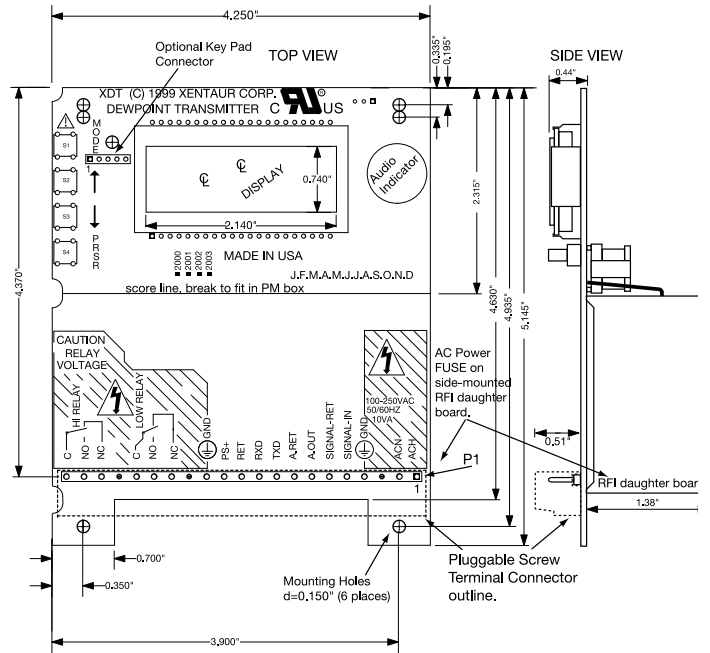

Dimensions XDT-NEMA

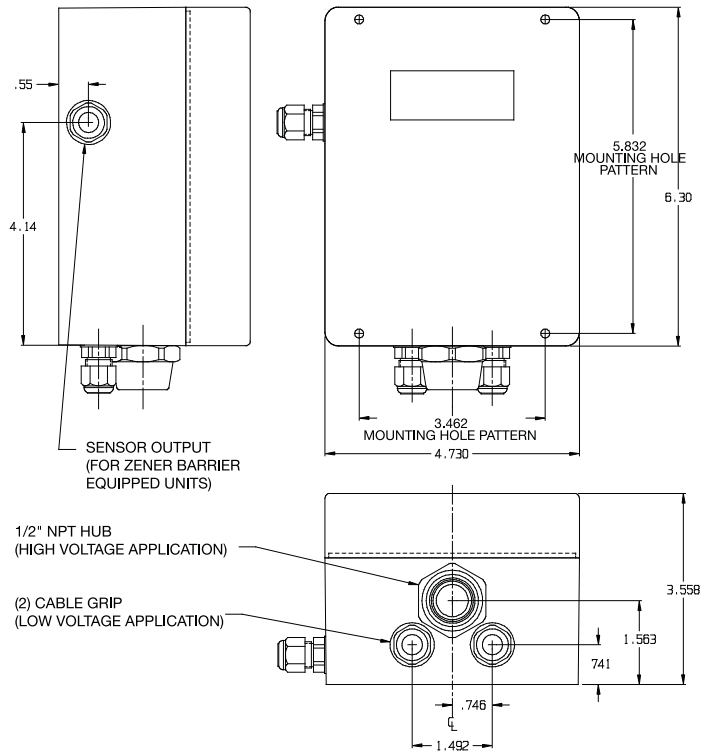

Dimensions XDT-PM

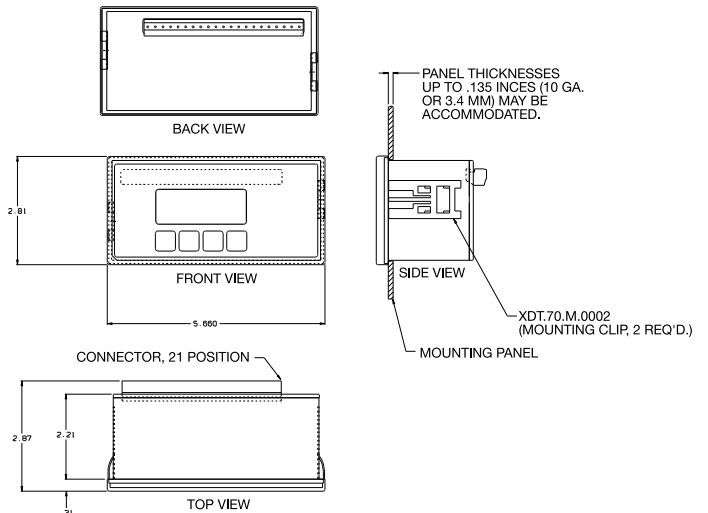

GAIN REAL-TIME INSIGHT INTO YOUR PROCESS

Process Insights manufactures and delivers premium sensors, monitors, detectors, analyzers, instrumentation, and software that are mission-critical to keep your operations, personnel, and the environment safe – every day across the globe.

Get the most reliable, precision analytical technologies available on the market today. We will work to match your needs and budget, and provide the optimal, and most stable process analysis solution for your application.

ETA Process Instrumentation

www.etapii.com
sales@etapii.com
tel: 978.532.1330

New England

Martech Controls

www.martechcontrols.com
sales@martechcontrols.com
tel: 315.876.9120

Upstate New York

For a complete range of products, applications, systems, and service options, please contact us.

COSA Xentaur, Tiger Optics, Extrel, Alpha Omega Instruments, ATOM Instrument, MBW Calibration, MGA, Guided Wave, ANALECT and LAR TOC Leader are trademarks of Process Insights, Inc.

REVOLUTIONIZING MEASUREMENT

EVERYWHERE